



“You have  
to dream  
before your  
dreams can  
come true.”

# किर IITH

the crowning glory...

A humble tribute to Missile Man of India  
"Dr APJ Abdul Kalam"  
on his 90<sup>th</sup> Birth Anniversary

A quarterly e-newsletter of IITH | Volume 3 | Issue 3 | Jul - Sep 2021 | #EpitomeofEnergy@IITH



IITH Solar Park - Pic Courtesy: Lijin Lohithakshan

## **Inside the Issue**

**Editorial Epistle| 4**

**Director's Desk| 5**

**Dean's Diary**

- Perfecting Perspective and Partnerships| **KID: 20210301| 6**

**Executive Diary**

- Paris 2015 agreement and the role of technological Institutes| **KID: 20210302| 7 - 8**

**Research Diary| 9 - 18**

- Design and Development of Functional Materials for Energy Storage Devices @CARBON Lab, IITH| **KID: 20210303| 9 - 10**
- Biofuel-based energy generation in India - is this a feasibility at the country level?| **KID: 20210304| 11 - 12**

**Wind Energy harnessing @ GOKUL, IIT Hyderabad| KID: 20210305| 13**

- Wind Energy Research at IIT Hyderabad| **KID: 20210306| 14 - 15**

**India 1st Electronic COVID-19 Test Kit - COVIHOME| KID: 20210307| 16**

- mPTX for enhanced sperm competence for IVF| **KID: 20210308| 16**
- Rakshak Face Shield| **KID: 20210309| 17**
- India's first Bio Bricks-based building inaugurated at IITH| **KID: 20210310| 17**
- Lounging @IITHHostels, One Space - Many Experiences| **KID: 20210311| 18**
- A strategy to save vision using DCM Hydrogel| **KID: 20210312| 18**

**Students' Diary| 19 - 26**

- Sustainable energy and Indian villages| **KID: 20210313| 19 - 20**
- Alternatives to the conventional solar power plant| **KID: 20210314| 21 - 23**
- Radiant Cooling: Designing an Energy Efficient Strategy| **KID: 20210315| 24 - 26**

**Alumni's Diary| 27 - 36**

- Towards near Battery-free IoT Sensor Devices| **KID: 20210316| 27 -28**
- Never Give-up| **KID: 20210317| 32**
- Thermoelectric Energy Harvesting: Concept, Challenges, and Technology| **KID: 20210318| 32 - 34**
- Alumni Seminar Series @Department of MSME| **KID: 20210319| 35 - 36**

**Incubatee's Diary| 37- 41**

- Activities by iTIC Incubator at IIT Hyderabad| **KID: 20210320| 37 - 39**
- Startup at iTIC - BluPower| **KID: 20210321| 40 - 41**

**IIT Raichur's Dairy| 42 - 44**

**IITH in the News| 45 - 47**

**Campus Corner| 48 - 60**

**Moments of Pride| 61 - 64**



# Editorial Epistle

Dear Readers,

We hope you are doing well!

It is indescribable support received from you that made किरIITH an attainable affair, and we are pleased to present the 8<sup>th</sup> issue of किरIITH.

Alike every time, this issue of किरIITH is also being dedicated to a thrust area of significant importance at IIT Hyderabad. We are glad to release six theme-based issues of किरIITH from COVID-19, AI, Healthcare, IITHinJapan, 5G & Next-Gen Tech to NanoTech. Following this precedence, किरIITH is back with yet another critical thrust area "Energy".

We hope this issue किरIITH - **The Crowning Glory, Issue-8, October 2021 #EpitomeofEnergy@IITH** will give you an exhilarating experience about exceptional research work carried by the IIT Hyderabad fraternity.

This issue of किरIITH is released on October 15, 2021, to pay a humble tribute to "**Missile Man of India, Bharat Ratan, Dr A P J Abdul Kalam**" by sharing it with all our stakeholders on his 90<sup>th</sup> birth anniversary.

किरIITH will be back next quarter with another trending research area. So, stay connected. We wish everyone a safe and healthy stay.

Enjoy reading!

“

"Change without continuity is chaos. Continuity without change is sloth and very risky."

- Max De Pree



Prof C Krishna Mohan  
Dean (Public & Corporate Relations)  
{Editor-in-Chief}

Prof Deepak John Mathew  
HoD (Design)



Ms Mitalee Agrawal  
Public Relations Officer



Ms Tisha Pantawane  
Media & PR Head, Student Gymkhana, IITH



# Director's Desk

Prof B S Murty

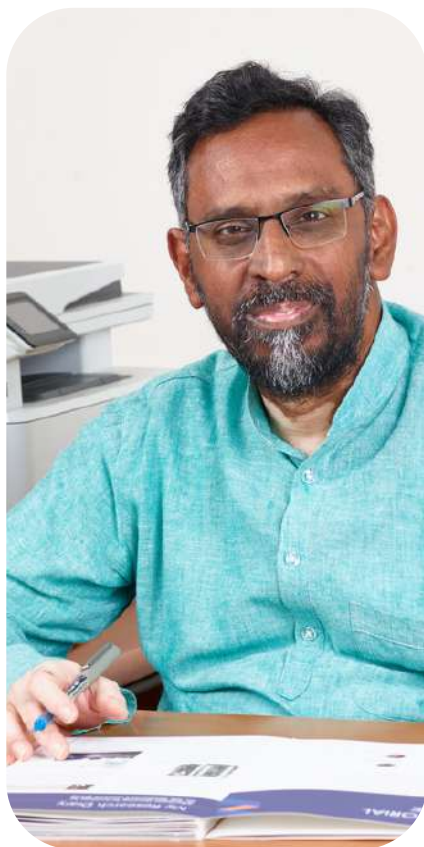

Dear Friends,

We hope you are doing well!

It is exciting to see how we are coming back to old normal for person-person interactions though the gathering is limited to small numbers and organized keeping in view COVID-19 protocol. We have successfully conducted the third successful vaccination drive on the IITH campus last quarter to add an extra protection cover to the residents. However, COVID-19 was never a speed breaker in our last two years' journey. We have not only set a new benchmark in academics & research but also elevated the campus's experience.

Last quarter was one such successful closure with the conduct of **Natfoe-2021** in association with INAE. We have also organized the **Joint Convocation** for 2020 & 2021 graduates with a total of 1323 degrees being awarded along with **Japan Day-2021** conducted virtually this September.

Research is ongoing perseverance ,and I am glad to share a few pivotal outcomes in this issue e.g., **COVID-19 Test Kit** with CCMB certification, **mPTX** for enhanced sperm competence for IVF, 1st **Bio Brick Building** at IITH under BUILD project, followed by DCM Hydrogel for Cornea treatment.

This further gets evident from the recent NIRF Ranking wherein IITH has retained its **Top-10** slot among

Technical Institute in the country & has been ranked among **Top-15** under **Research Category**.

Another advancement in our research portfolio is the MoU with institutes & organizations of International & National Repute. Namely, **PharmCADD, IISc, IAMRAI, IPE, RGKUT, Military College of Electronics & Mechanical Engineering, and Kepler Aerospace - Aidin**.

On the academic front, we successfully commenced the **semester-long internship** and working towards initiating **new industrial-oriented BTech programs**, starting this year.

Notable progress has been made towards campus development with the **inauguration of four State-of-the-arts facilities** by Hon'ble Minister of Education, **Shri Dharmendra Pradhan**, the establishment of **Resource Recovery Plant**, IITH own **sub-post office**, and **14-inch Telescope**.

Hope we conclude this year amazingly & remain connected.

We are happy to bring to you the **8<sup>th</sup> issue of क्रिIITH on Epitome of Energy @IITH**. I hope you will all enjoy going through this informative issue bringing out the excellent research going on at IITH in the field of **Energy**.

**Stay Safe, Healthy & Happy...**

“

**"Your Largest Fear carries your greatest success".**

**- Matty Lonze**

# Dean's Diary

KID: 20210301

## Perfecting Perspective and Partnerships

Prof C Krishna Mohan, Dean (Public & Corporate Relations)

Two years ago, Public & Corporate Relations was established to develop a positive perspective of the IIT Hyderabad by creating the brand "IITH" alongside keeping persisting efforts to develop a partnership with the Organizations & Institutes of International & National repute.

Since the beginning, we have kept a strong focus on a solid foundation of the Public & Corporate Relations Office (PCRO). We have studied the working philosophy of various Public Relations/ Media Relations/ Corporate Relations Office from the premier institutes in India and abroad. After identifying the existing problems, we have structured PCRO into two verticals: (i) Public Relations to look after the institute perspective and ensure only authorized information flow out and, (ii) Corporate Relations Office, house the Placement Office that has been transformed to Office of Career Services (OCS) to focus on overall career setting of the students. Besides OCS, Corporate Relations Office also ensures effective liaisoning between Institute and Corporates and facilitates the seamless transfer of knowledge between the two entities and growth prospects of the two.

During this journey, we had many momentous occasions that includes:

- Release of 1st of **KirIITH** by our BoG Chairperson Dr BVR Mohan Reddy,
- Launch of **PCR & OCS website** for easy interface to interested parties,
- **Benchmarking placement & Internships** during COVID-19
- **Self-sustain** Public Relations Office
- Successful commencement of **Semester-long internships** for BTech
- **Electronic Press Release**
- **Wider Outreach** of IITH with **4X social media audience**

PCRO is all aspired to be the window of opportunities for the IITH fraternity by providing necessary support.

**Stay connected & insure trusted relation in turn...**



“Every success story is a tale of constant adaption, revision & change.”  
- Richard Branson



Fig. 1: Mission-Vision Model of Public & Corporate Relations Office



# Executive Diary

KID: 20210302

## Paris 2015 agreement and the role of technological Institutes

- Prof D Chandrasekharam

TUBITAK Fellow, Izmir Institute of Technology (IIT-Izmir)

Former Visiting Professor Indian Institute of Technology Hyderabad

The Conference of Parties (countries) 21, on 12 December 2015 in Paris made a landmark agreement to control the GHG emissions to combat climate change and limit the global temperature increase below 2 degrees (also known as 2D -scenario). 191 countries have adopted the agreement and committed that the countries will prepare, communicate and maintain a national determined contribution, known as NDC, to achieve the goals. It took 21 meetings for the countries to come on to a common platform and reach this agreement. The agreement was kept open for signature by all parties (191 countries) from 21 April 2016 till 22 April 2017. It will be enforced once 50 % of the countries sign the agreement. On 4 November 2016, it has come into force as 55 % of the countries signed the agreement. Hence it is historical.

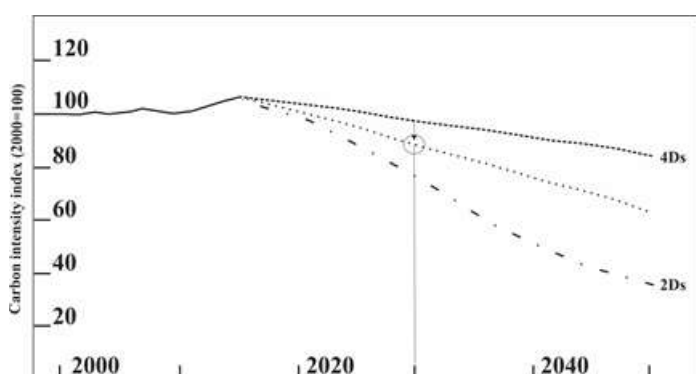

Fig. 2: Carbon intensity index –time-renewable energy relationship. (Carbon intensity index of energy production is measured as the quantity of carbon dioxide emitted per unit of energy production. This is measured in kilograms of CO<sub>2</sub> per kilowatt-hour).

The remaining countries delayed signing the document because they could not find alternate energy sources that can generate base-load electricity and work with an efficiency of > 80% and with low CO<sub>2</sub> emissions. But now with the development in energy technologies, other countries are coming forward to sign and implement the carbon reduction process through renewable energy sources like geothermal. Last week Turkey agreed to implement Paris 2015 agreement by increasing the percentage of heating and cooling of homes using ground-source heat pumps and using geothermal hot waters for district heating. Thus the country can offset 80% of the energy supplied from fossil fuels through this decision.

Countries like India, located in tropical climate regions, can use heat from the ground for air-conditioning and save over 80 % of energy being used for this purpose from coal-based thermal power plants. Institutes like IITs can make a small contribution by adopting this method to cool and heat their homes, hostels, and working laboratories.

Currently, IITH accommodates about 85 families and 4000 students (assuming life in hostels is normal....back to non-Covid status) and annually consumes about 4 million kWh of electricity, generated from coal-based thermal power plants. There is no data on the energy consumption by the various laboratory units. Here the institutes like IITs need to create a cell to audit the energy consumption.

An energy audit is now becoming an important part of any industrial unit in the world. Coming back to the amount of power consumed by the residents of the campus, the amount of CO<sub>2</sub> emitted is about 4 million kg annually (1 unit of power generated by coal-based thermal power plants releases 1 kg of CO<sub>2</sub>) At least 50% of this emissions can be avoided if ground source heat pumps are put in place for cooling and heating. Now, this technology is freely available across the countries, it is a question of policy and mindset of the implementing agencies to adopt this technology. Now that the new academic units are coming up on the campus with Japanese collaboration, district cooling and heating concept can be adopted right during the construction stage (this process can be implemented after the construction of the buildings but a small amount of cost can be saved if it is done during the construction stage). The advantage is, Japan has implemented this process of saving energy and reducing carbon footprint using ground-source heat pumps a long time ago in their country. IITs should showcase this technology so that other industrial and academic campuses can follow and help the country in successfully implementing the Paris 2015 agreement which the country has committed.

During the Covid period, although the Indian as the well global economy was badly hit (Figure 2) due to reduced electrical usage during the Covid-19 period starting in 2019, it is predicted by the International Energy Agency that global electricity demand will surge beyond 2019 level and concurrently increasing the CO<sub>2</sub> emissions and the GDP. It is all the more important for India to plan a strategy contain CO<sub>2</sub> emissions through promoting the earth's heat for cooling and heating purposes.

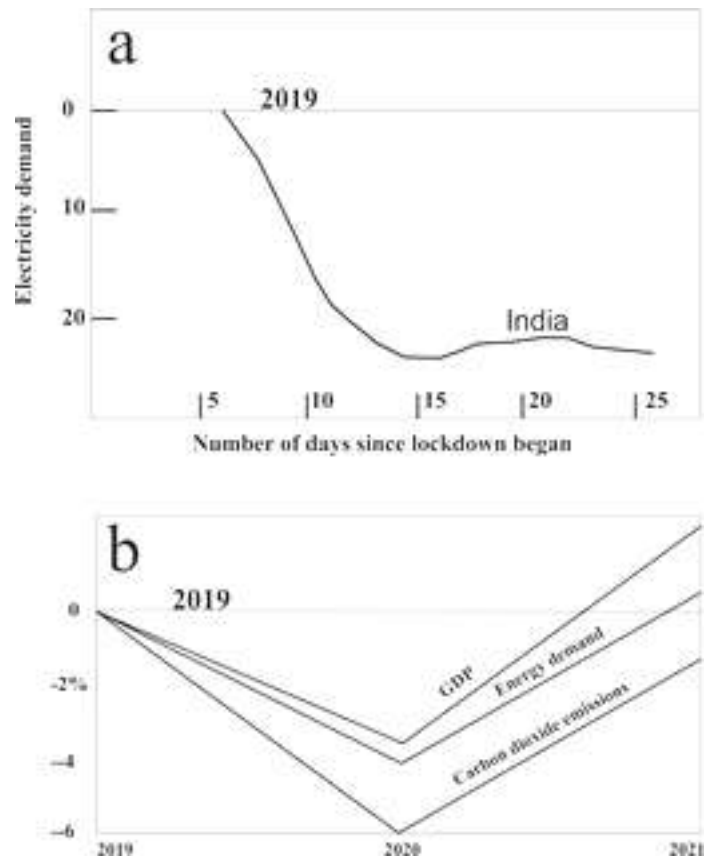

Fig. 3: Energy demand during Covid-19 period (a) and future global electricity demand and CO<sub>2</sub> emissions (b) (adopted from International Energy Agency Global Energy review, 2021)

To initiate this strategy, IITs should have an energy audit unit to create a data bank on the usage of electricity and emissions. Small initiatives from industries and educational and research units will certainly help in bringing the curve to 3D level if not 2 D level (Figure 1).





# Research Diary

KID: 20210303

## Design and Development of Functional Materials for Energy Storage Devices @ CARBON Lab, IIT Hyderabad

Dr Anil D Pathak (L) (Post Doctoral Fellow) and Dr Chandra S Sharma (R) (Associate Professor, Department of Chemical Engineering

“Energy” is in the core of every economic, environmental, and developmental aspect impacting the global economy significantly. At present, the primary energy sources in the world are oil, coal, and natural gas. Considerable use of these energy sources has led to colossal CO<sub>2</sub> emissions that are acidifying our oceans and also responsible for global warming. This has raised a question worth pondering that if any energy source can enable modern civilization to secure a clean, efficient, and reliable, and sustainable energy supply for all people and reduce the imprint on air pollution of the internal combustion engine and coal-fired power plants.

To address these issues, we are presently exploring renewable and rather clean energy sources like solar, wind, geothermal, ocean, and other carbon-neutral sources. However, due to the intermittent nature of these energy sources, we need state-of-the-art and more efficient energy storage technology to make effective utilization of energy as per the demand. Rechargeable batteries and supercapacitors have thus received tremendous attention in the last two decades or so. Among them, Lithium-ion batteries (LIBs) are one of the widely explored electrochemical devices used in smartphones, laptops, and most other consumer electronics. Commercially available LIBs have graphite electrodes with a theoretical capacity of 372 mAh/g, which limit the use of LIBs in the electric car, grid, and even for space application. Here in our lab, we aim to design and develop more efficient electrode materials for advanced lithium-ion batteries and other battery chemistry such as lithium-sulfur (Li-S), lithium-carbon dioxide (Li-CO<sub>2</sub>) and, supercapacitor which can be used in electric vehicles to aircraft space applications as summarized below:

### Advancement in lithium-ion batteries for accelerating the devices:

We first time demonstrated the use of the candle soot-based carbon nanomaterial for high-rate lithium-ion batteries to address the long-time charging issues associated with the adoption of electric vehicles across the world. Further, the catalytic graphitization of resorcinol-formaldehyde xerogel enables a fine balance in graphitic content in hard carbon addressing the challenges of capacity fading and poor electronic conductivity associated with hard carbons as an anode in Li-ion batteries (LIBs). Besides modifying the physicochemical properties of these carbon materials, we also focused on the novel design aspects of anodes to achieve high rate performance. Unlike the conventional planar electrodes (2D) with higher mass loadings, we even extended the concept of 3D electrodes to fabricate hierarchical and hybrid 3D electrodes using a combination of Carbon MEMS approaches with electrospinning, hydrothermal synthesis, or drop-casting. Simple strategies like the use of pencil trace coating on the current collector suppressed the side reactions and facilitated in achieving excellent capacity retention. Furthermore, a combination of MOF with 3D carbon electrodes was helpful in achieving significantly higher reversible capacities in these electrodes.

### Lithium-sulfur (Li-S) batteries for long-range electric vehicle application:

Lithium-sulfur (Li-S) batteries present a promising solution to replace the conventional lithium-ion batteries (limited driving range ~160 km) due to the high theoretical specific capacity (1675 mAh/g; driving range ~500 km) and specific energy density (2500 Wh/kg) of the sulfur cathode.

However, the commercialization of the Li-S battery is challenging because it suffers from the electrochemical intermediates (polysulfides) dissolution in an organic electrolyte which lowers the coulombic efficiency and cycle life of the Li-S battery.

These issues of Li-S battery are being addressed at CARBON Lab by developing carbon-metal oxide material as a host and interlayer for Li-S battery. It has been observed that the conducting carbon-based sulfur host and interlayer can confine polysulfides physically and also chemically to overall improve the cycle life of the battery. The use of these strategies also shows effective utilization of the active electrode of Li-S cell for long-range application of the devices with low environmental impact.

#### Supercapacitor for boosting power of electric vehicle:

The supercapacitor is another energy storage device that can be recharged instantly and can provide the necessary large amount of power to accelerate the vehicle, but they have limited energy density compared to the battery system. Here, we present an ingenious approach to convert bio/other waste (Borassus Flabellifer fruit skin and cork powder waste) into carbon and also directly used candle soot carbon to fabricate electrodes for the development of sustainable supercapacitor as an energy storage device with optimum energy and power density.

In yet another approach, we developed metal sulfide/oxide-candle soot-derived carbon composites for high-performance supercapacitor applications. As-developed symmetric as well as asymmetric devices show significantly improved electrochemical performance compared to the existing commercial carbon-based supercapacitors and therefore, have a high potential for electrical vehicle applications.

#### Rechargeable Li-CO<sub>2</sub> battery chemistry for Mars exploration:

Space agencies worldwide are exploring the red planet (Mars) in the search of signs of life. However, Mars exploration missions require a robust, highly efficient, high-energy-density with long cyclic stability rechargeable batteries that can function in even harsh conditions. Here, we have introduced the first time a functioning prototype of Li-CO<sub>2</sub>Mars battery chemistry using a porous carbon cathode made from candle-soot carbon. The development of high energy density Li-CO<sub>2</sub>-Mars batteries can also be justified in terms of significant mass and volume reductions, both of which are essential in the Mars Lander and Rover missions. Another aspect of this work is to develop efficient Li-CO<sub>2</sub> battery systems and provide a striking option to fix CO<sub>2</sub> emissions and environmental protection.

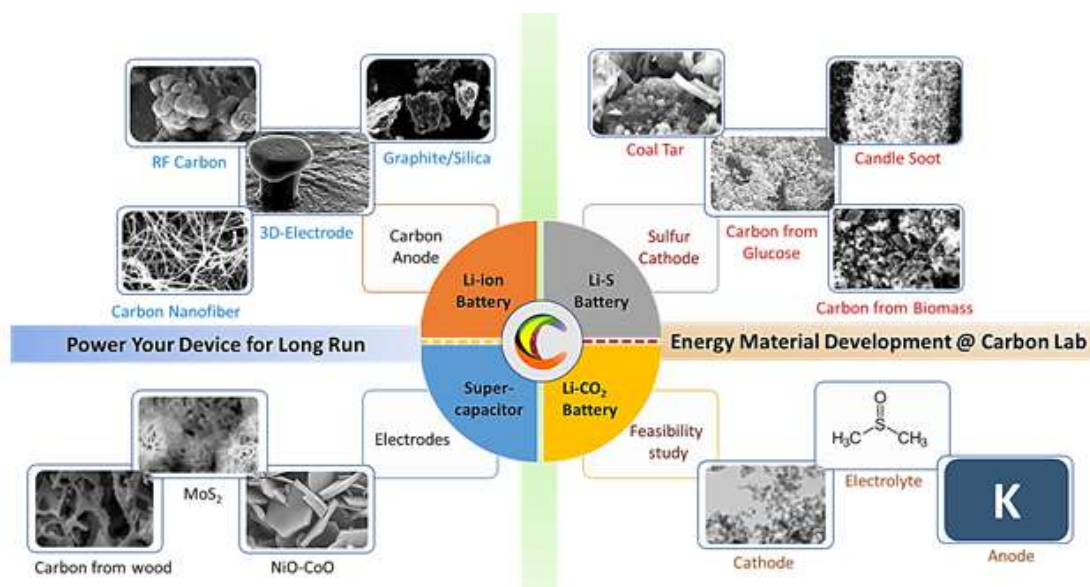

Fig. 4: Schematic of design and development of functional materials for energy storage devices @ CARBON Lab



# Research Diary

KID: 20210304

## Biofuel-based energy generation in India - is this a feasibility at the country level?

- Prof Kishalay Mitra  
Head - Department of Chemical Engineering

One of the vibrant global issues i.e. how to tackle the increase in energy demand with depleting conventional fossil fuels is currently addressed through optimal usage of non-conventional energy sources namely solar, wind, tidal, geothermal, and bio sources. For a developing nation like India, where 70% of the population depends on forest and agriculture, the bioenergy sector can play a vital role that is yet to be utilized to its full potential. The national initiatives towards blending 20% biofuels with fossil fuels are catalyzing this fact further. Some of the existing challenges in this sector are (i) biofuels have a calorific value less than fossil fuels leading to more quantity of biomass needed for energy generation, (ii) need of Flexi-fuel engines costlier than regular engines, (iii) food vs fuel issues for 1st generation biomass, (iv) availability of biomass throughout the year due to seasonal nature of crops in addition to their heterogeneity in composition across geographies.

Despite a lot of research happening at individual levels to ameliorate the current state-of-the-art technologies for energy conversion from different bioresources, a novel approach has been adopted by Global Optimization and Knowledge Unearthing Laboratory (GOKUL) to attack these problems holistically from the vantage point of a supply chain (SC) network designer.

An SC bridges several entities present in different echelons (material supply, manufacturing, distribution, and collection) involved in converting the raw material into the finished goods and enables a designer to find possible avenues of improvement in the whole product life cycle. An endeavor towards designing such a country-wide supply chain network has been successfully attempted for the first time considering the target of blending 20% of both bioethanol and biodiesel for a future time horizon (2018-2026) using 2nd generation biomass.

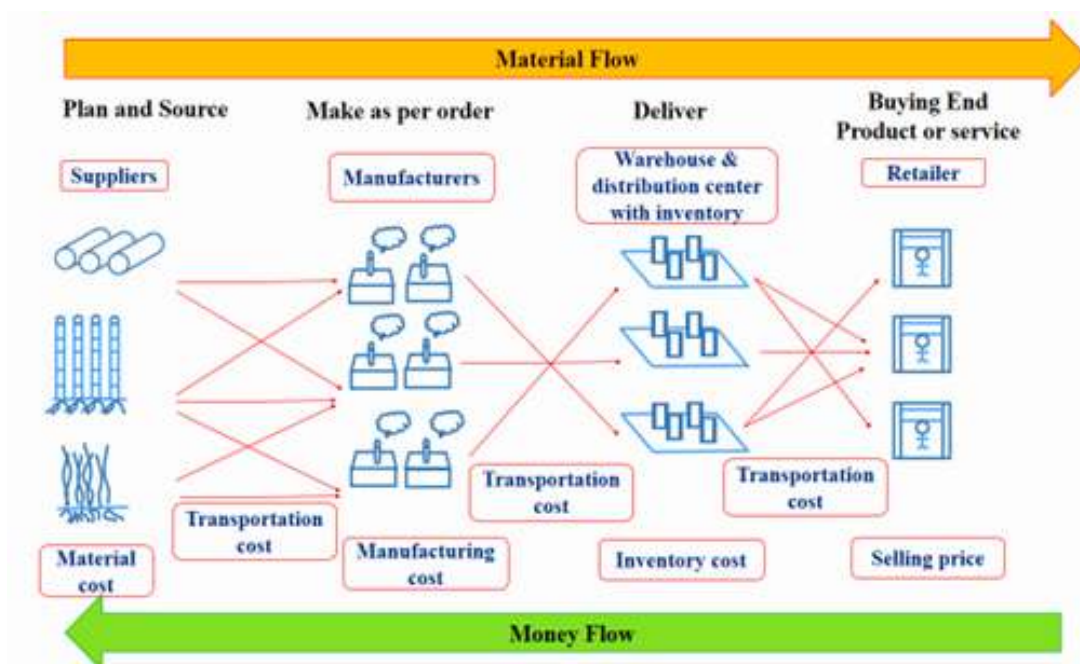

Fig. 5: General overview of Supply Chain Network Design

The objectives of the SC to maximize the profit net present value and simultaneously minimize the pollution causing greenhouse gas emissions (GHGe) have been achieved through mixed-integer linear programming, which is NP-hard to solve. External importers are also included to manage the shortfall in indigenous production and to maintain the product quality in terms of research octane number. The unique SC model covers all three aspects of technology, economy, and environment keeping sustainability in mind. From the technology side, the model deals with the choice of site location, capacity planning, multi-connection routing, the choice for mode of transport considering biomass to biofuel conversion yields for several raw material choices to handle seasonality issues. Considering the time value of money and depreciation, economic calculations are performed not only tackling the capital and operating expenditure but also through the GHGe emission, GHGe savings, and conversion of carbon savings into carbon credits representing the environmental aspects.

Further, to make the SC design realistic, stochasticity in biofuel demand, import price, and biomass feed supply has been modeled using a data-driven robust optimization approach. Overcoming the drawbacks of conventional robust optimization, the adopted approach performs accurate transcription of uncertain parameter space using unsupervised machine learning approaches, which resulted in more accurate, non-conservative robust solutions. In addition to being bestowed with the best paper award by the International Federation of Automatic Control Conference (ACODS 2020), the project findings are published in the prestigious International Journal of Cleaner Production on several occasions.



Fig. 6: Collage of Media response to the Bio-fuel based energy generation idea



# Research Diary

KID: 20210305

## Wind Energy harnessing @ GOKUL, IIT Hyderabad

- Prof Kishalay Mitra  
Head - Department of Chemical Engineering

Even though state-of-the-art technologies are developed across the world to harness renewable energy, the efficiency remains low due to the uncertain and nonlinear nature of such resources. Though India is abundantly blessed with a potential wind resource, a large-scale profitable establishment for renewable energy conversion systems in India is rarely seen due to the uncertainty associated with it. Additionally, a common problem faced in the domain of windfarm modelling is the computational expense related to simulating the entire study. Thus, windfarm layout optimization, wake modelling, uncertainty handling, and control studies during energy harnessing from wind are still at inception with respect to the Indian subcontinent.

The development of a robust wind energy conversion system is need-of-the-hour to offset the energy crisis and drastic environmental issues India is facing in current times. At Global Optimization & Knowledge Unearthing Lab (GOKUL), we proposed novel methodologies to design optimal windfarms from the grassroots level by combining the fields of deep learning, CFD, combinatorial & evolutionary optimization, and uncertainty analysis. Further, we are working on new robust wind farm control strategies using reinforcement learning. Such a unique framework can resolve several issues faced by wind farm owners and ensure designs that can last for a long-term duration. The current status, scope for improvement, and novelties in the proposed work are presented below:

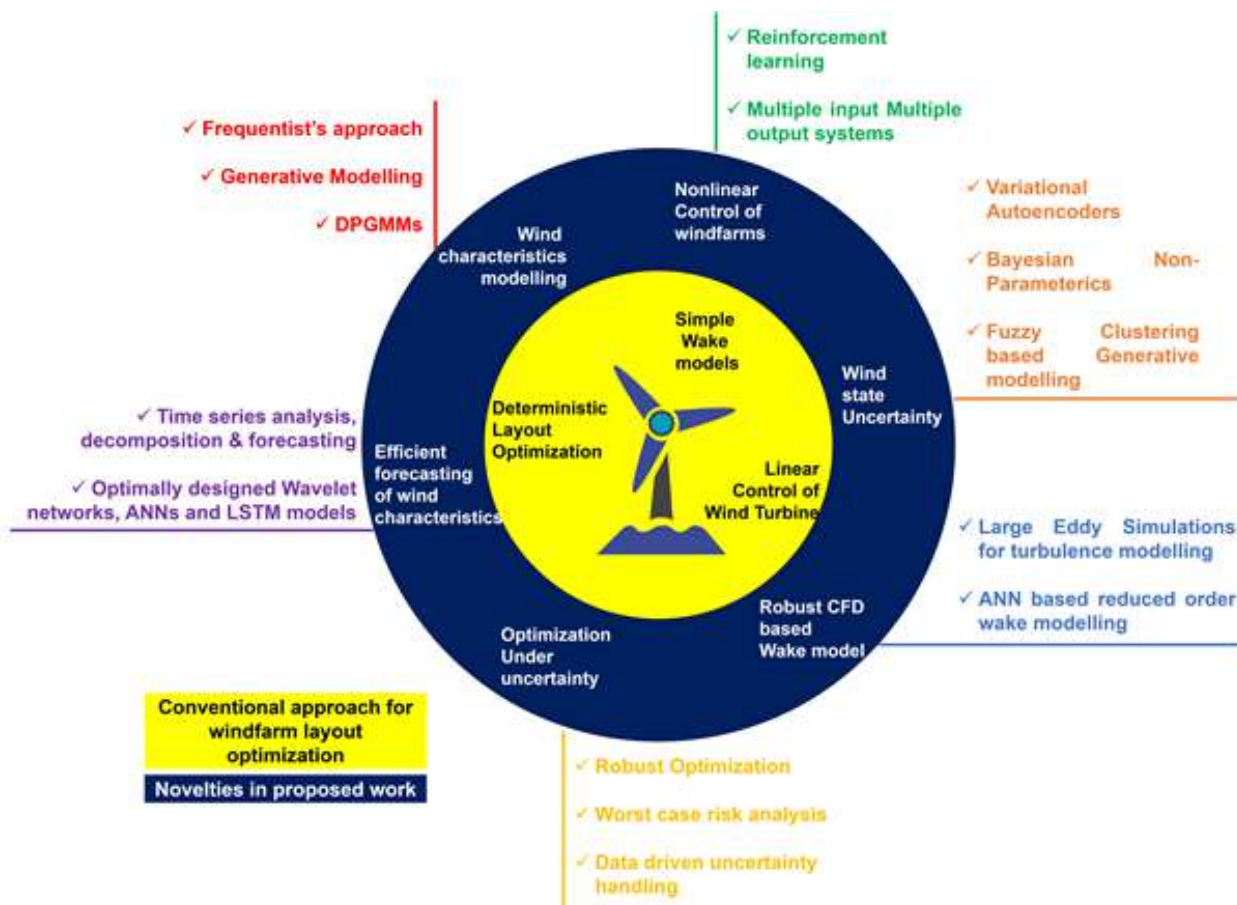

Fig. 7: Novel works being performed at GOKUL in the field of Wind Energy

- Realizing the need for forecasting wind characteristics data due to their limited availability, a novel heuristic-free optimal design algorithm for building nonlinear deep learning-based system-identification techniques has been proposed. Also, the abilities of generative models like Gaussian Processes and Variational Autoencoders are utilized in combination with a clustering-based generative model for accurately modelling the uncertain nature of wind.
- The novel ideas developed in the lab have led to 14 high-impact peer-reviewed publications of international repute and two high-value Government projects worth INR 1 crore with international collaboration for the establishment of large-scale efficient wind farms. The funding agencies include DST - National Supercomputing Mission, SPARC - MHRD, and special fund by British Council UKIERI through the international collaboration with the University of Exeter, UK (Department of Computer Science).
- Methods for modelling turbulent wake effects in wind farms are focused on next. Here, machine learning-driven accurate models are developed, which would be fast as compared to high fidelity CFD-based models.
- As a whole, the wind farm layout optimization problem turns out to be NP-hard MINLP formulation. To convert such a large-scale problem to a small scale, an auto-encoder-based strategy is proposed, which assists efficient usage of combinatorial, evolutionary, and hybrid optimization algorithms for micro-siting.
- To make it realistic, wind state uncertainty in the micro-siting formulation is considered and solved using Robust Optimization. Moreover, wind farm control studies using reinforcement learning are performed.

## Research Diary

KID: 20210306

### Wind Energy Research at IIT Hyderabad

Dr Niranjan S. Ghaisas,  
Department of Mechanical and Aerospace Engineering



Wind energy is one of the fastest-growing sources of renewable energy worldwide and in India. Per MNRE, the installed capacity in India exceeds 40 GW as of late-2020. Despite this, there are several issues that preclude the widespread penetration of wind into the Indian and global energy mix. The importance of harnessing energy in a clean and efficient manner leads to several exciting interdisciplinary research opportunities, targeted towards, e.g., making accurate wind forecasts; designing aerodynamically efficient, less noisy, and structurally robust wind turbines; & designing better wind-farm layouts

and optimal control strategies that maximize energy generation and minimize maintenance/repair costs. Our group at IITH studies fluid dynamics associated with several of the challenges outlined above. The primary tools employed are high-fidelity large-eddy simulations (LES) of the turbulent flow over wind turbines and wind farms embedded in the atmospheric boundary layer (ABL). Due to the wide range of length and time scales involved, these simulations are extremely expensive, requiring extensive use of supercomputing resources (available in India via NSM-funded clusters at IITH, IISER Pune, etc., and internationally).

These large-scale LES are accompanied by the development of simplified analytical, statistical, or semi-analytical models that reproduce the key results (e.g., mean wind speed or average power production) at a fraction of the cost of the LES.

A turbine located in the wake (in the wind shadow) of an upstream turbine sees lower wind speeds and increased turbulence. Consequently, the downstream turbine generates lower power than the upstream turbine; this phenomenon is termed 'wake losses'. Minimizing wake losses is key to ensuring effective utilization of the wind resource. Wake losses are inherently tied to wind-farm design and operating parameters as well as features of the incoming ABL flow. Some challenges specific to the Indian context are the effect of non-flat/undulating/hilly terrain and the effect of surface heterogeneities. Some key results obtained in the last few years are provided below (see Figure 7).

(1) Multi-rotor wind turbines, wherein four three-bladed rotors are mounted on a single tower, is a relatively new turbine configuration with structural and aerodynamic benefits over the conventional single-rotor configuration. Our recent work quantifies the reduced wake losses that are observed in finite-sized wind farms of multi-rotor turbines (Ref. 1),

and in very large wind farms, and develops an analytical method to predict the mean wind speed accurately.

(2) Differences in land use and land type (agricultural/fallow; urban/ rural; forested/ semi-arid), or type of surface (water/ land), affect the wind patterns over it. The flow is known to accelerate or decelerate over a surface transition. We have developed a fully predictive analytical model that captures the strength of this acceleration/deceleration of the flow for different transitions (Ref. 2). Current efforts are aimed at understanding how and why wind farms located on such heterogeneous surfaces behave very differently as compared to those on homogeneous surfaces.

In summary, the field of wind energy offers several exciting interdisciplinary research opportunities for students in various disciplines ranging from fluid dynamics, structural mechanics, atmospheric sciences to control theory, optimization, and data-driven approaches.

### References:

1. N. S. Ghaisas, A. S. Ghatge, S. K. Lele, Wind Energy Science, vol. 5, pp. 51-72, 2020.
2. N. S. Ghaisas, Boundary-Layer Meteorology, vol. 176, pp. 349-368, 2020.

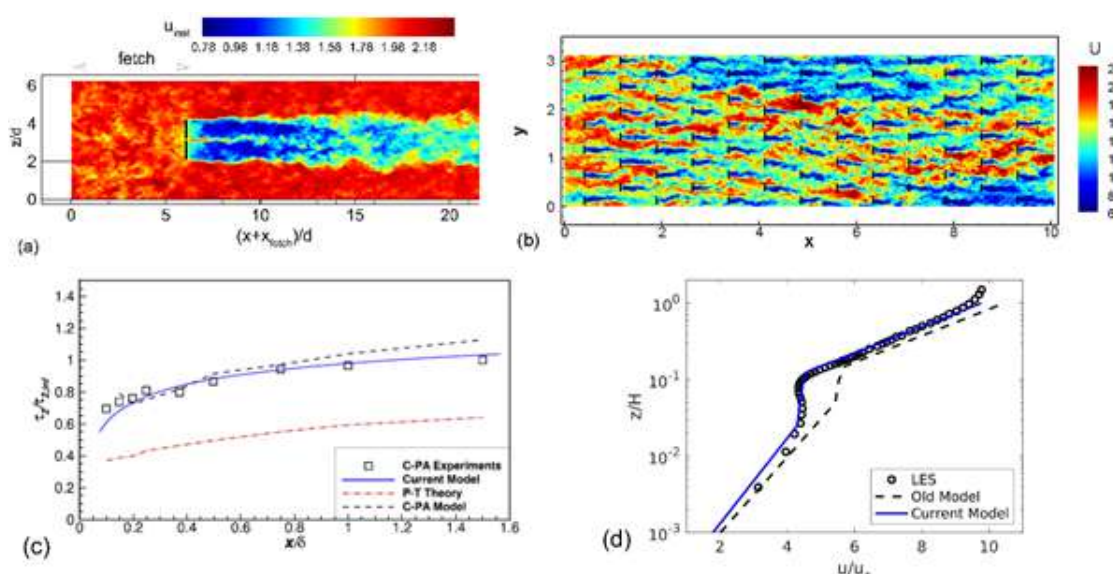

Fig. 8: Contours of the instantaneous velocity field behind (a) a stand-alone multi-rotor wind turbine, (b) a very large wind farm. Thick black lines denote turbine rotors. Analytical model predictions for (c) the shear stress behind a surface roughness jump compared to previous models and experiments and (d) mean velocity profile in very large wind-farms compared to a previously proposed model and LES results

# Research Diary

## Innovations - Q3

India 1st Electronic COVID-19 Test Kit - COVIHOME

Prof Shiv Govind Singh

KID: 20210307

IIT Hyderabad's Prof Shiv Govind Singh developed India's First Bio-electronic COVID-19 Rapid Electronic Test Kit, "Covi-Home". Validated by CCMB Hyderabad (ICMR partner institute), Covi-Home is ready for Technology Transfer.

### Highlights:

- Validation Report: Specificity: 98.2% Sensitivity: 91.4% Efficiency: 94.2%.
- Works with Oral/ Nasopharyngeal Swabs, Testing Volume: < 10 µL.
- Oligo-based testing (Equivalent to RT-PCR testing).
- Smartphone-based Home-testing.
- Test results within 30 min.
- Low cost ~Rs. 300/Test.
- No RNA-extraction is required.
- No RT-PCR is required for load amplification and testing.

Read More: <https://tinyurl.com/dx9sypv9>

View Video Abstract:

<https://youtu.be/NVBCXfJdbOU>

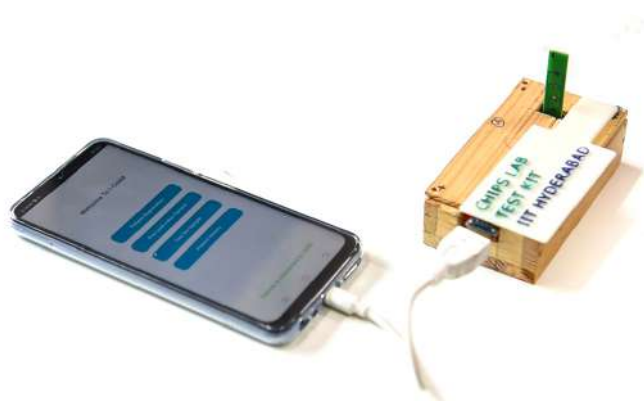

Fig. 9: COVIHOME

mPTX for enhanced sperm competence for IVF

Dr Rajkumara Eerappa

KID: 20210308

IIT Hyderabad along with Kasturba Medical College, Manipal Researchers, designed a molecule 'mPTX' to enhance sperm competence for IVF. mPTX, can increase sperm motility, prolong in-vitro sperm survival and improve sperm fertilization potential compared to the widely used pharmacological agent, pentoxifylline, in IVF technology.

### Highlights:

- mPTX enhances motility and longevity of sperm from patients with poor motility.
- Reduces embryotoxicity.
- mPTX treatment prevents premature acrosomal reaction in sperms.
- mPTX treated sperms have better DNA integrity.
- mPTX can be a better drug for enhancing sperm competence for IVF.

Read More: <https://tinyurl.com/sknbyrp7>

View Video Abstract:

[https://youtu.be/grUr-9\\_X7cw](https://youtu.be/grUr-9_X7cw)

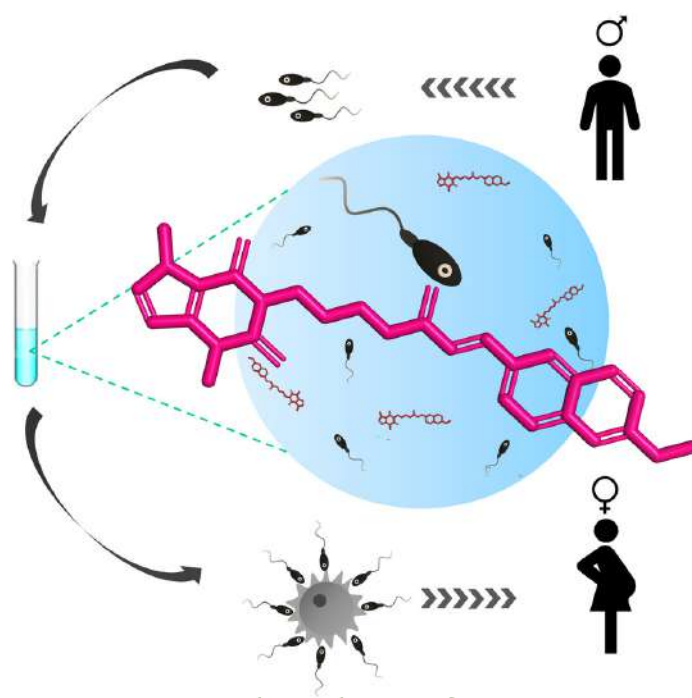

Fig. 10: Working Schematic of mPTX



# Research Diary

**Innovations - Q3**

India's first Bio Bricks based building inaugurated at IITH  
Mr Priyabrata Ruatray

**KID: 20210310**

Based on the patented technology, agro-wastes are converted into sustainable material to built eco-friendly and cost-effective buildings.

**Highlights:**

- This technology was developed to counter the air pollution caused by stubble burning. Bio-Bricks are quite economical, farmers can make this material at the site and further reduce the labour costs.
- This material exhibits excellent thermal insulation and fire-retardant properties. When used in roofing and wall panelling, it can effectively reduce heat gain by 5 - 6 degrees. Bio-Bricks can also add to the marginal farmers' income and create a new employment opportunity in the lean period (off-seasons).
- Bio-Bricks are found to be 1/8 and 1/10 of weight for similar volume compared to burnt clay bricks and concrete blocks, respectively. Compared to burnt clay bricks, Bio-Bricks will cost about Rs.2 - Rs.3 when mass-produced. Bio-Bricks has a sustainable material that can reduce dependency and allow villagers to built cost-effective buildings.

**Read More:** <https://tinyurl.com/5zkux6e5>

**View Video Abstract:**

[https://youtu.be/iOFOUXrmw\\_w](https://youtu.be/iOFOUXrmw_w)

Rakshak Face Shield by the maker of Sudhikran  
Mr Priyabrata Ruatray

**KID:20210309**

With the onset of COVID 19, we need a large number of protective gears, and a cost-effective and modular face shield will protect doctors and frontline workers from bodily fluids and reduce the risk of infection through the eyes and ears. This design is modular and requires significantly less time to make using only a few materials.

**Highlights:**

- Easy to use.
- Easy to manufacture.
- Prevents strain from hard parts on the forehead.
- Easy to assemble.
- Easy to change the shield.

**View Video Abstract:**

<https://youtu.be/t1u1OnLjkYw>



Fig. 11: Rashak - Face Shield



Fig. 12: 1st Bio Brick Building at IIT Hyderabad

# Research Diary

## Innovations - Q3

Lounging @IITHHostels, One Space - Many Experiences

Dr Neelakantan

KID: 20210311

The objective of this design studio is to reimage/ reinterpret an existing place. Idea was to imagine what accordances are possible in the place.

### Highlights:

- Recreation of the existing place.
- IITH's POD was chosen as a case study.
- Multipurpose furniture is created.
- The purpose was to create a bond among POD members to psychological positivity.

### View Video Abstract:

<https://youtu.be/NbGOgYy3Y7E>

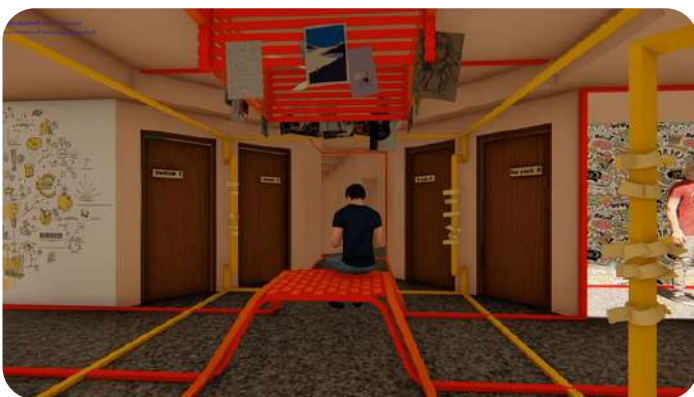

Fig. 13: Snapshots from Design Studio

A strategy to save vision using DCM Hydrogel

Dr Falguni Pati

KID: 20210312

This technology offers a minimally invasive procedure to prevent scarring following corneal injury and also a new treatment strategy to cure the existing blinding scar for which the currently available option is corneal transplantation. Also, a human-sized cornea has been fabricated by Bioprinting technology towards the development of artificial cornea for transplantation.

### Highlights:

- This technology was developed using discarded cornea from slaughterhouses and disqualified cornea for transplantation from Eye banks. The processing method is simple and using only eco-friendly and harmless chemicals.
- Preclinical studies indicate that the corneal scar for which cadaveric corneal grafting is the only available option currently, can be cured using this hydrogel.
- Introduced, for the first time, a preventive measure using this hydrogel for corneal scarring following traumatic corneal injuries.

Read More: <https://tinyurl.com/36bb9y59>

### View Video Abstract:

<https://youtu.be/SrK6UvSpfyk>



Figure 1. Preparation, decellularization, and biochemical characterization of dCMHs (A1) bovine cornea, (A2) mouse cornea, (A3) decellularization process (A4) after lyophilization, (A5) DCM solution preparation, (A6) prepared DCM solution, (B) Gelation after pH adjustment and incubation at 37 °C for 45 min, (B1) Physical properties of dCMH after cross-linking that attained scoopability, (B2) Image depicting the nonfloating behavior of dCMH after cross-linking, (C) Retained ECM components and DNA after tissue normalization, (D) Retained sGAG and collagen before weight normalization of native and decellularized corneal tissues, (E) H&E staining of native and decellularized corneal tissues.

Fig. 14: Working Schematic of DSM Hydrogel



# Students' Diary

## Sustainable energy and Indian villages

Samkeet Sangai (R) and Heera (L)

MTech 1st Year - Energy Science and Technology

KID: 20210313

At the beginning of the 20th century, Mahatma Gandhi had declared: **“The soul of India lives in its villages”**.

Ambitious pledges towards carbon neutrality by mid 21st century were made under the Paris agreement, by all emerging economies including India. The potential of Indian villages to catalyze the country's pace to decarbonization and towards a green and circular economy is huge. India's rural electrification program has made huge strides in the power sector. With the culmination of Deen Dayal Upadhyaya Gram Jyoti Yojana (DDUGJY), electricity reached all of India's 597,464 villages, achieving universal electrification. Despite this milestone, the last-mile supply still remains a distant dream. Streamlining distribution is a task, which is impeded by several factors, geographical disparity being one. The remoteness of the location and grid connectivity poses itself as a major problem.

On the other side of the picture, India is primarily an agrarian country that possesses abundant renewable energy sources, most of which are untapped. Grievances regarding grid connectivity and the ever-increasing dependency on conventional sources might have overshadowed the possibility of connecting these two dots more often than not. Making the village's energy self-sufficient would prove a solution to India's intermittent nature of rural electrification.

The idea could be achieved in a more decentralized approach by harnessing the locally available non-conventional resources. Tapping these effectively, would not only deliver to the rural energy requirements but also, provide a comprehensive and circular approach where the concept of waste is nonexistent.

The plan is to be tailor-made to suit the nature and resources availability of the village in question. This is dependent on the demography, occupation, spatial distribution of land, extent of agrarian and domestic residues, and the energy requirement of the village. The load profile is not as high as that of urban areas, and the energy demands basically come under agricultural, domestic, and community.

India's vast agricultural potential provides a huge opportunity in the bioenergy sector as agro-residues, which can be used to meet energy needs both in heat and power applications. Biomass gasification, combustion, efficient cookstoves, biofuels are some methods of harnessing the available renewables, which, unlike fossil fuels, are pollution-free and the raw materials readily available to agrarian households.

Depending on the cultivation pattern and land use distribution, the plan is to integrate the fragmented farmlands by promoting multi-cropping and encouraging animal husbandry(dairy farming, poultry, piggery, etc). On the boundaries of the farm, based on land topography, Jatropha, cassava, switchgrass, and other biofuel generating plants can be grown. In addition, this practice helps in better farm management and brings down overall cost on input. To optimize and monitor crop growth operations, agricultural drones can be used. This phytogeomorphological approach would be useful in assessing the agricultural growth stability with respect to topological terrain attributes. The well-defined decision support system for farm management is a good practice towards precision agriculture.

A high amount of residues, plant and animal wastes (dung, food wastes), ie the slurry from the farms, which are usually carelessly disposed off and cause environmental pollution, are collected.

The crop residue transformed using gasification or anaerobic technology can be used to generate sustainable, non-polluting electricity. The crop residues and organic wastes of low heat value, taken as feedstock can be converted into combustible gas and then fed into a generator for electricity generation. This can be a greater alternative to the conventional open field mass burning, which is environmentally hazardous and unmindful to the prospects of energy generation from the resources.

A powerplant with an oil expeller, filter press, and a boiler can be used to extract biofuel from the fuel plant produce. In addition, the oil wasted from cooking can be filtered and transesterification is performed to generate biofuel, using an automated biodiesel processor.

In the areas where biogas production is constrained due to the limited availability of locally produced resources, solar energy can be developed into two alternative options as hybrid and standalone electricity systems. Concentrated solar cells concentrate direct solar energy to heat using a reflector and concentrator. The amount of energy received per area of solar collector depends on the concentrator design, and when the design is efficient, it is a better alternative to traditional cooking stoves in terms of energy efficiency and eco-friendliness.

In arid and semi-arid areas, solar photovoltaic cells with good conversion efficiency can be used to satisfy the appliance electricity demand. But the limiting factor for solar PV adoption in rural areas is cost. Due to economic inconceivability and low voltage applicability, large solar PV panels may not always be a feasible option when individual households are concerned.

But a combination of both concentrated and PV cells together could cater to the cooking demands of a lower unit such as a household.

A solar water pumping system finds significant applications in meeting village water supply and irrigation purposes. The viability is subject to variation of solar radiation and water table condition can enable replacement of diesel operated water pump sets.

Another means of harnessing solar energy is through a water heating system which can be installed on the ground, terrace, or rooftops. When the sun rays penetrate through a toughened glass and fall on the absorber, the heat of the sunrays is absorbed by the cold water inside, thereby increasing its temperature. This is an energy-efficient and cleaner alternative to firewood and other conventional resources. Environmental pollution is greatly minimized.

India's great solar energy potential with about 5000 trillion kWh energy incidents per year over the mainland, from an energy security perspective, presents itself as the most secure of all renewables. The proper harnessing of a fraction of the irradiant energy offers capacity addition and power generation on a decentralized scale. Application of the same has benefitted villages by catering to their heating, lighting, and cooking demands. According to the estimation done by the National Institute of Solar Energy, India's solar potential scales to about 748 GW if 3% of the wasteland area is to be covered by Solar PV modules. Employing hybrids of geographically available renewable sources offers a stable energy supply and optimum utilization of localized resources. The electricity demand of the village can be met by itself, by integrating the abundant renewables and exploiting the potential of energy generation from residues usually wasted away. This would surely be a stride towards self-reliance and a circular economy, wherein the aim lies to replace dearth with sufficiency.



# Students' Diary

## Alternatives to the conventional solar power plant

Samkeet Sangai

MTech 1st Year - Energy Science and Technology

KID: 20210314

Since the invention of the first commercial solar panel in 1881, by Charles Fritts, there has been tremendous development in photovoltaic technology which has reduced cost and increased the efficiency of solar power plants. Solar power is pollution-free and causes no greenhouse gases to be emitted after installation. India has made significant development in generating capacity for solar energy in the last few years. However, factors including lack of financing support, inconsistent government policy, lack of scale and competition from low-priced Chinese imports led to the decrease in India's domestic module manufacturing growth. Indian government introduced certain measures such as the Domestic Content Requirement and the safeguard duty to reduce cheap imports. Later, schemes were launched to reserve 50 percent of the project's bid capacity for solar cells and modules manufactured indigenously, while allowing the remaining 50 percent capacity to be set up using imported modules. But this was challenged in the World Trade Organization by the United States. As a result, the process of reserving capacities in the projects bid for solar cells and modules manufactured domestically was stopped in January 2018.

### Need for alternatives to conventional solar power plants:

Although solar power plants are one of the best technologies to produce electrical energy from the sun because of the dependency of solar panel manufacturing on China its availability is questionable. Solar energy is not available throughout the day and conventional solar plant is unable to use other sources for generating electricity except sunlight which creates problem in absence of sun.

The traditional solar power plant also needs high initial capital cost, they are hard to integrate with existing infrastructure and huge land requirements. There is a need to find alternative ways of harvesting this huge amount of energy received on the earth's surface from the sun.

### What options do we have?:

There are lots of alternatives for conventional solar power plants for generating clean energy. We are mainly going to focus on the following two alternatives:

1. Transparent solar cells
2. Solar thermal power plants

### Transparent solar cells:

Transparent solar cells absorb only infrared and ultraviolet light and Visible light passes through the cells unimpeded. The figure below shows its components and how they work together. The thickest layer (toward the left) is the glass, plastic, or other transparent substrate being coated; the multiple layers of the PV coating are toward the right. At the core of the coating are the two active layers - the absorptive semiconductor materials that get excited by sunlight and interact, creating an electric field that causes current to flow. Sandwiching those layers are electrodes that connect to the external circuit that carries the current out of the device. Since both electrodes must be transparent and not the usual reflective metal a layer on the back of the cell can be added to reflect sunlight of selected wavelengths, sending it back for a second pass through the active layers. Finally, anti-reflective coatings can be used on both outside surfaces to reduce reflections because any light that reflects - potentially as much as 10% of the total - doesn't go through the device.

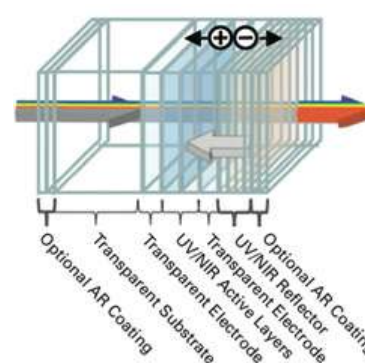
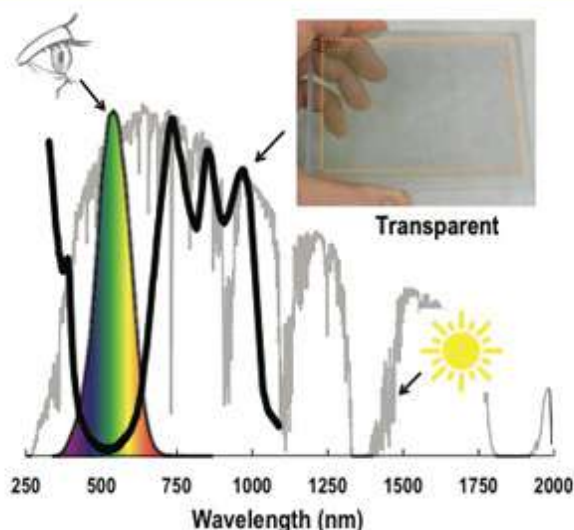
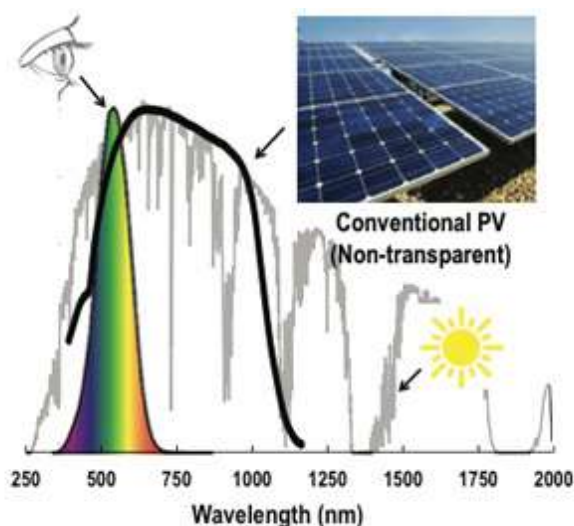

Fig. 15: Sample Transparent Photovoltaic Device

To compare the operation of the transparent solar cells, the researchers measured their absorptive response and then compared it with that of a conventional solar cell. The results appear below. The absorptive response (black curve) of conventional solar cells is superimposed on the solar spectrum (gray curve). In the conventional solar cell (top), the wavelengths at which absorption is relatively high include the visible part of the spectrum that our eyes can detect (the colored section between about 400 and 700 nanometers).

While on other hands transparent solar cell (bottom) absorbs in the infrared and the ultraviolet parts of the spectrum—both above and below the visible range. But in the visible region, absorption drops off, approaching zero.



**Solar thermal power plants:**

Most techniques generating electricity need a high temperature to achieve reasonable efficiencies example are coal power plants. The output temperatures of non-concentrating solar collectors are limited to temperatures below 200 °C. Therefore, concentrating systems must be used to produce higher temperatures. The reflector, which concentrates the sunlight to a focal line or focal point, has a parabolic shape; needs to be tracked using some motor sensors control system to achieve higher efficiency.

The reflector can be further divided into one-axis and two-axis tracking: one-axis tracking systems concentrate the sunlight onto an absorber tube in the focal line, while two-axis tracking systems do so onto a relatively small absorber surface near the focal point.

The energy collected from the sun is then used for heating water at higher temperatures to produce steam which is feed to the steam turbine which converts the kinetic energy of steam to electrical energy.

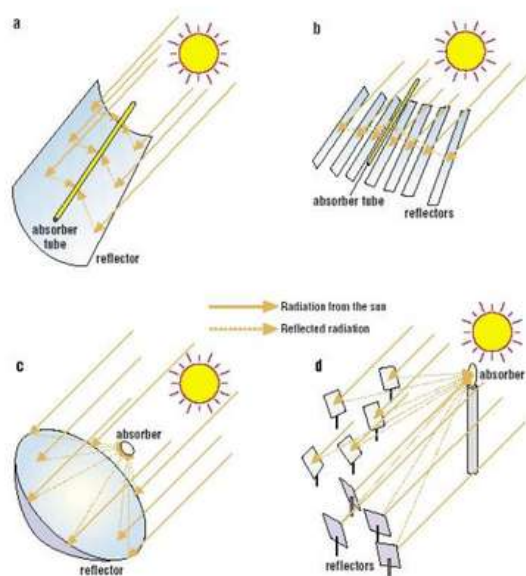

Fig. 17: Concentration of sunlight using (a) parabolic trough collector (b) linear Fresnel collector (c) central receiver system with dish collector and (d) central receiver system with distributed reflectors

Fig. 16: Spectral response of conventional and transparent PV

Advantage of using Transparent solar cells and solar thermal power plants over conventional solar: Transparent solar cells has the advantage of easy integration with existing infrastructure than conventional solar cells. The coating could easily be deposited on one of the inner surfaces of double-paned windows, along with standard low-emittance or solar-control coatings. Distributing the energy generated by the Transparent solar cell equipped windows could be as simple as placing a wire connection, power electronics, and an outlet at the side of each window or series of windows. Moreover, the Transparent solar cells would block much of the infrared radiation. That effect could cut down on air conditioning needs, further reducing energy use and operating costs in the building. Transparent solar cell use also solves the problem of not being in my backyard as no land is needed for Transparent solar cells. The initial cost of installing a Transparent solar cell is low compared to a conventional solar cell.

Solar thermal power plants have the advantage of guaranteed capacity. During periods of bad weather or during the night, a parallel, fossil fuel burner can produce steam; this parallel burner can also be fired by climate-compatible fuels such as biomass, or hydrogen produced by renewables. With thermal storage, the solar thermal power plant can also generate electricity even if there is no solar energy available.

**Conclusion:**

Due to the increase in global energy demand, there is an increased need for the development of more such alternatives to conventional solar panels which can produce electricity depending on the requirements of different locations. Further research needs to be carried out to increase the efficiency of already existing technology to make it commercially viable.

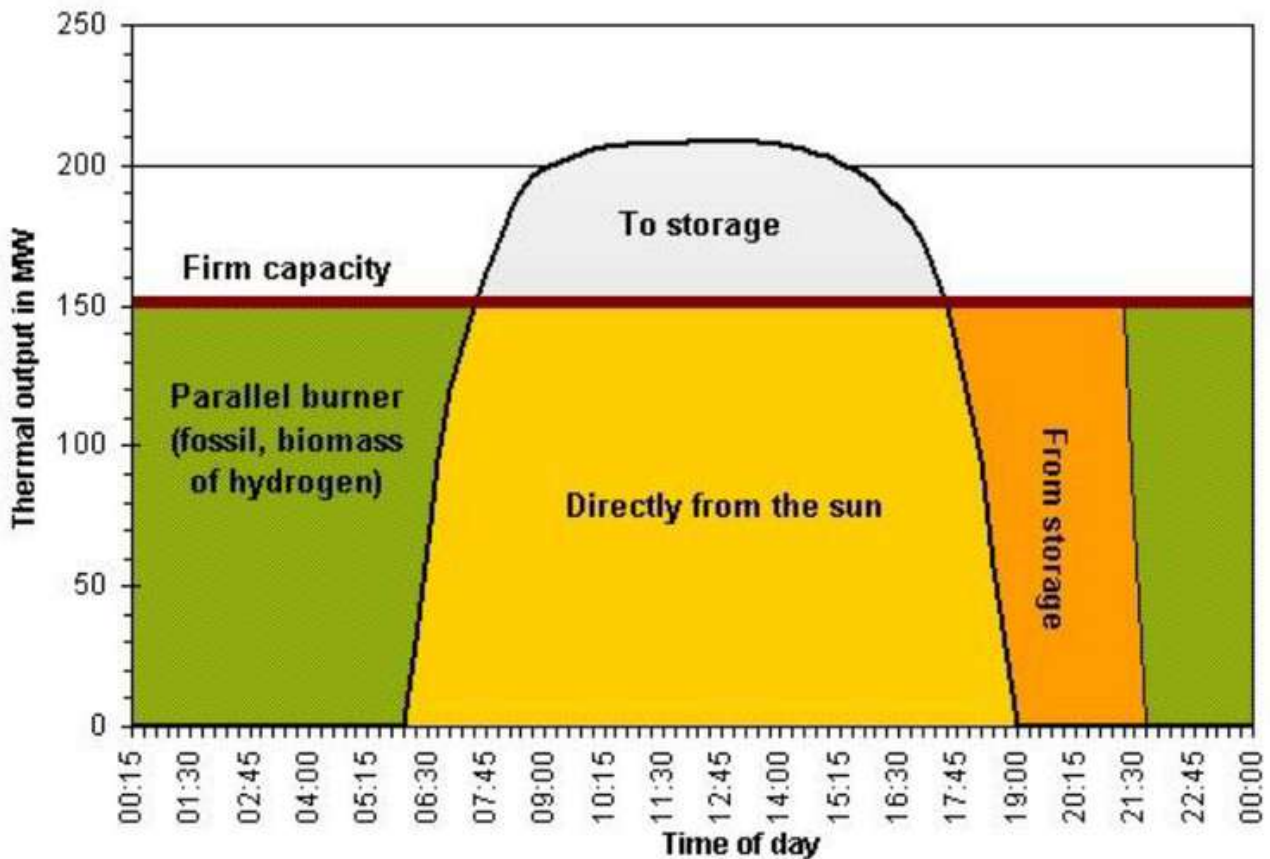

Fig. 18: Typical output of a solar thermal power plant with two-hour thermal storage and backup heater to guarantee capacity



## Radiant Cooling: Designing an Energy Efficient Strategy

Saurav S Sankhe

MTech 1st Year - Energy Science and Technology

KID: 20210315

In the current generation, many conventional cooling systems adopt air conditioning systems where the cooling load is purely convective. Traditional air conditioning techniques tend to blow air directly on people for more extended periods, which chills people instead of cooling them, making them less comfortable. So instead of blowing air directly on the people, why not control the temperature of walls. This methodology is known as radiant cooling.

All air conditioning systems are designed on convection mode only; the radiant cooling system provides heating and cooling by combining radiation and convection in a space. ASHRAE (The American Society of Heating, Refrigerating and Air-Conditioning Engineers) defines radiant systems as temperature-controlled surfaces where 50% or more of the design heat transfer occurs by thermal radiation.

### Principle of Radiant Cooling

Circulating water is more efficient than circulating air because of its physical and thermal properties. Water can carry 3,400 times the energy that air can carry for the same volume. This property of water is used to achieve a maximum advantage in a radiant cooling system. Also, the natural way the human body dissipates heat is mainly through radiation, as shown in the figure. These two criteria are utilized in radiant cooling.

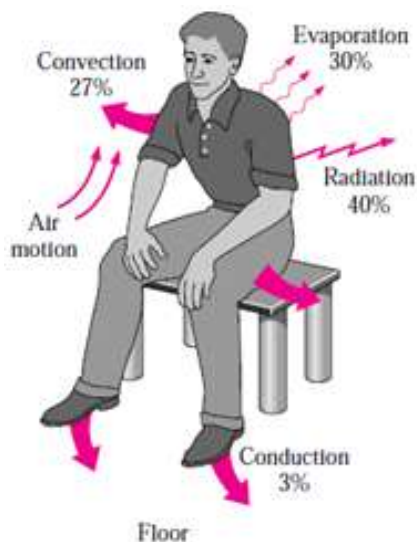

Fig. 19: Mechanisms of heat loss from the human body and relative magnitudes for a resting person

Coldwater flows through pipes embedded in the slab and cools the entire slab resulting in the slab surface being maintained at about 20 °C. Cooling inside the space is achieved when the cold slab absorbs the heat (radiation) generated by people, computers, lighting, and other equipment which are exposed to the slab. Fresh air is supplied through an air system to maintain a healthy indoor environment and to control the moisture inside the office space. In other words, the sensible heat load can be addressed by the cooled slab, and the latent heat load can be addressed by the Dedicated Outdoor Air System (DOAS).

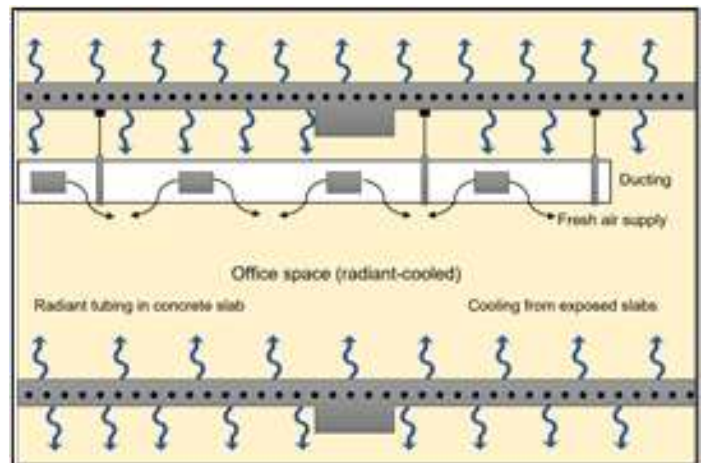

Fig. 30: Model of Radiant cooled space

### Types of Radiant Cooling:

Depending on the position of the piping in the building, the radiant system is usually classified into three types:

- Embedded surface systems (pipes placed within a building layer (floor, wall, ceiling) which is isolated from the main building structure).
- Thermally activated building system (TABS) (pipes integrated into main building structure (ceiling, wall, floor)).
- Radiant panel system (pipes integrated into light-weight panels).



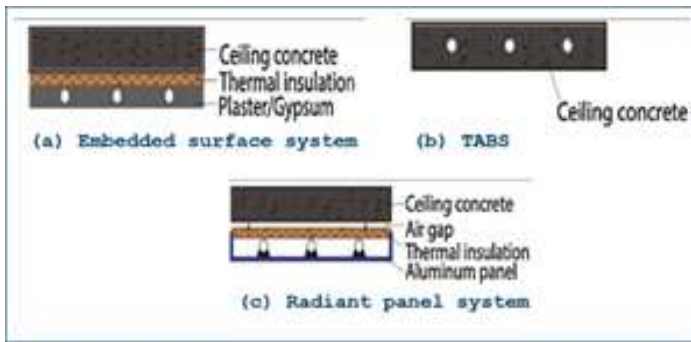

Fig. 21: Types of Radiant Cooling

### Radiant v/s Conventional Cooling

At peak demand (during hot summer days when cooling in the building is generally needed), the conventional HVAC system uses about 37.5% of its power on tasks like the fan and motor for air distribution. The remainder of the loads is accounted for by the chiller and compressor units. It is important to note that only a fraction of this air supply is needed to ventilate a building and maintain excellent air quality properly. This realization is causing much research in developing new innovative technology involving radiant systems, which require less circulated air and less wasted energy from fans and motors. As discussed earlier, water has a much higher heat carrying capacity allowing for increased efficiency over all-air systems. Using this concept for a simple numerical example wherein a room is to be cooled having a total sensible load of 100 kW with a temperature difference of 14 °C. When calculating the amount of power required to cool this space, a fan (for conventional air conditioning) comes out to be 14.2 kW, whereas for a pump (for Radiant Cooling) comes out to be 1.6 kW. It proves that the electrical demand of circulator water through the pump is only 11% of the fan motor to transfer the same amount of heat energy. It could save a lot of electricity.

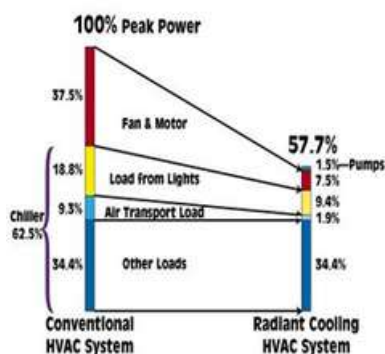

Fig. 22: Running power contributions for both the systems

the most significant feature of this building is that it is split into 2 identical halves: one with conventional air conditioning and the other with radiant cooling. Both building halves have a separate set of equipment and were extensively metered for accurate energy comparison. The building inaugurated this system in 2011, and the results so far have been highly satisfactory. The radiant cooled half of the building has been consistently showing a significantly lower energy consumption than the conventional half.

This building serves as a myth buster for a market where cost and risk significantly influence any new technology implementation. The building has redefined the efficiency standards and will serve as a benchmark for the industry and be a global case study for radiant cooling technology with the most accurate comparisons of energy, comfort, and cost.

A few salient features of the HVAC design of the building for both conventional and radiant systems are listed below:

#### Conventional air-conditioning system:

- High-efficiency chiller, pumps, (Air Handling Units) AHUs, and cooling tower, all with variable speed drives
- Chilled water design temperatures: supply 7.8°C, return 15.6 °C (high. T design).
- Primary variable flow pumping system.
- Cooling tower approach: 2.2 °C.
- AHUs with energy recovery wheel, evaporative cooling section, and free cooling option for different ambient condition advantages.
- Low-pressure piping and ducting design
- (Variable Air Volume) VAVs for controlling airflow in office spaces.

#### Radiant cooling system:

The radiant slab was designed to give a cooling output of about 75 W/Sq.m, whereas the office loads were in the range of 50 W/Sq.m due to the highly efficient design of the building and efficient lighting and computers.

- High-efficiency chiller, pumps, AHUs, and cooling tower, all with variable speed drives.
- Chilled water design temperatures: supply 14°C, return 17 °C.
- Ducting unit was provided with the DOAS for achieving dehumidification, but this was replaced by a chilled water coil in Aug 2011 as a retrofit to achieve higher efficiency in the system.
- Primary variable flow pumping system.
- Cooling tower approach: 2.2 °C.
- DOAS with an energy recovery wheel for supplying dehumidified fresh air into the office spaces.
- Low-pressure piping and ducting design.

**Energy Results:**

The design of the building and the building systems were estimated to be about 40% more efficient than the ASHRAE baseline building. In 2011-12, the total consumption in the conventional air conditioning system was about 440000 units, and in the radiant cooling system was about 269000 units.

The conventional air-conditioning energy index was recorded to be 38.7 kWh/Sq.m, and the radiant cooling energy index was recorded as 25.7 kWh/Sq.m. So, the radiant cooling system was 39% lower in energy consumption than the conventional air-conditioning system for Apr 2011 – Mar 2012.

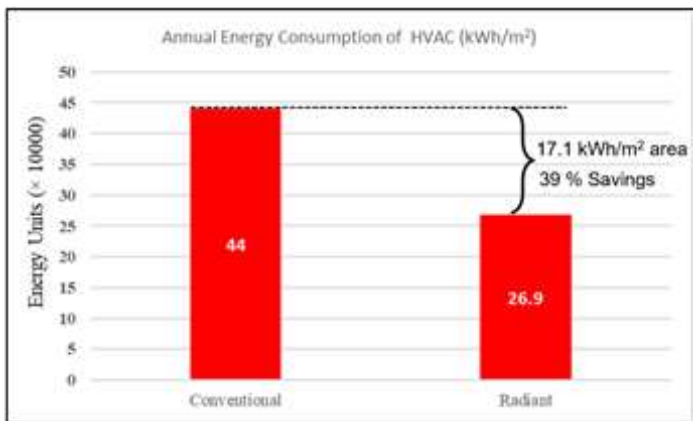

Fig. 23: Annual electricity consumption of the conventional system and the radiant cooling system

**Comfort:**

The radiant cooling system inherently provides a healthier indoor air quality as there is no recirculation of air in the system. Treated fresh air provided to the occupants for maintaining healthy conditions and removing moisture from the space. In principle, the radiant cooling system reduces the Mean Radiant Temperature (MRT) of the space since the slab is cooled. Therefore, the perception of thermal comfort is expected to be higher for a radiant cooling system.

**Conclusion:**

The above report concludes that radiant cooling can be used as an alternative to energy-efficient buildings. It is also a replacement for conventional cooling techniques. The radiant cooling technique also has zero (Ozone Depletion Potential) ODP and (Global Warming Potential) GDP, reflecting one of the best environmentally friendly cooling techniques. By controlling the surface temperature of walls or floors, a custom variable temperature can be set up depending on the loads in the buildings, reducing the chiller and energy costs. However, the initial setup costs are much more than conventional cooling, but they can be compensated with the running costs in running periods. Radiant cooling also provides better adaptive comfort to the occupants. In the coming years, where protecting the environment is of significant concern, radiant cooling can be a better cooling system. It is being implemented in various western countries and is assumed to spread in India as well.



# Alumni's Diary

## Towards near Battery-free IoT Sensor Devices

Dr R Sai Chandra Teja (TL)

(MTech, 2012, PhD Osaka University),

Current affiliation (Chief Operating Officer, Green PMU Semi Pvt Ltd)

Dr K T Hafeez (TR)

(MTech, 2011, PhD, 2020),

current affiliation (Vice President Engg., Green PMU Semi Pvt Ltd)

Dr Ashudeb Dutta, Associate Professor (BL)

Dr Gajendranath Ch, Assistant professor (BR)

Department of Electrical Engineering

KID: 20210316

### I. Introduction

Energy harvesting is now receiving particular attention in the world of sensor networks. With the advancements in semiconductor technology and improved communication infrastructures, it has become possible to connect many sensors via a network and collect/utilize a large amount of information (Big Data). This network of numerous wireless sensor nodes along with the gateways and remote servers make the so-called IoT aka Internet of Things. In recent years, full-scale utilization of IoT systems has begun, and the movement to install sensors with communication functions is becoming active. However, a power source is required for these electronic functions to operate at all times. For this reason, it cannot be placed everywhere. In other words, while it is said that all things are connected to the Internet, the places where IoT devices can be installed are limited to those within the reach of humans. When the power source is a battery, there is originally no power wiring, but battery replacement is required which increases maintenance cost. Incorporating energy harvesting technology into the sensor eliminates the cost of electricity, eliminates the need for wiring to supply power, reduces construction costs, and increases the degree of freedom in sensor installation. Employing energy harvesting will reduce the Bill of Materials (BoM) of maintaining the network as well as increasing the lifespan of the edge devices.

With energy harvesting, there is no need to pull power lines and worry about battery replacement and charging. This will reduce construction costs and electricity costs. An even bigger advantage is that this will enable hassle-free maintenance of remote sensors and allow the scope of always-on real-time sensing. Hence the use of energy harvesting is attracting attention.

It is a technology that converts natural energy such as light, sound, vibration, temperature difference, and electromagnetic waves into electric power and uses it as a power source for electronic devices. The main idea is to convert the small amount of energy around us into electric power and utilize it. This energy conversion technology with an output of about  $\mu\text{W}$  to  $\text{W}$  that can be a stand-alone power source for small electronic devices is gaining traction and attracting interest of various sectors such as consumer electronics, military and aviation, smart healthcare, smart agriculture, wearables, smart mobility etc. In recent years, many high-performance, efficient harvesters have been commercialized, and the amount of power that can be obtained from these has increased significantly. For example, the power generation efficiency of solar cells continues to improve while the devices are becoming easier to use e.g., Dye-sensitized Solar Cells, which have high power generation efficiency within low light conditions such as indirect sunlight and indoor light. Thin and flexible organic solar cells are also an emerging technology trend.

However, properly designing an energy harvesting system is not so easy. Factors that previously did not have to be considered by electronics designers are so important that they determine the success or failure of the development. Until now, many electronic device designers have designed functions on the assumption that the power required to drive the device can be obtained abundantly.

However, energy harvesting equipment should be designed with the potential for power shortages and outages without warning. This is because the amount of power generated fluctuates greatly due to changes in the surrounding environment. The unstable power supply is a major premise for development. Wireless IoT nodes do not always match the timing of power generation and the timing of using electricity for transmission, and in the first place, it may not be possible to cover the amount of power that can be communicated unless a certain amount of power is accumulated. This calls for very stringent design conditions which can be addressed only by skilled electronics designers with niche expertise in developing energy harvesting solutions.

In recent years, power supply ICs designed for the use of energy harvesting has been commercialized, and this situation has improved considerably. These power supply ICs are designed to handle minute power, significantly reduce leakage current when not in operation, and increase conversion efficiency while driving low output currents. In the latest power supply ICs for IoT devices, analog IC manufacturers are now competing to reduce standby power consumption at the Nano-ampere level.

There is a paradigm shift in the energy market, which is the decentralization of power generation. In this trend, adopting energy harvesting technology, which can be said to be the ultimate distributed power source, will reduce power costs and the labor of battery replacement thus showing great promise for the spread of IoT technology.

## II. Energy Harvesting Technology

Energy harvesting is a key technology to realize the self-sustaining power supply drive of wireless sensors. This will make it possible to realize work-saving (no wiring work required) and maintenance-saving (battery replacement not required) and be effective for environmental consideration, energy-saving, and sustainable society.

It can be said that the self-sustaining power source by energy harvesting is established when the following four elements (A) to (D) are balanced.

### A. Power generation efficiency

In terms of performance metrics for designing an energy harvester, efficiency is of utmost importance. The magnitude of the rated power generation amount of the harvester depends heavily on the surrounding environment. When a sensor that measures temperature and humidity in an office is equipped with a power generation device that harvests from indoor light, depending on the location of the device the harvesting energy ranges from 10,000 lux to several hundred lux. Hence, energy harvester ICs must have a respectable and steady conversion efficiency under various operation conditions spanning across the entire spectrum of use cases.

### B. Power durability

It is often difficult to know how much power a sensor or communication module consumes. Especially for wireless communication, it is necessary to measure the standby power when it is difficult to connect or when there is no communication. In these situations, it is quite difficult to manage the power supply scheme for different conditions.

### C. Storage capacity

As the electric power system, a power storage device is indispensable for filling the gap between (A) and (B) by reserving the generated power for later use. Hence, the selection of an optimal power storage device is a challenge.

### D. Cost

Incorporating energy harvesting in an existing application requires proper R&D and meticulous design which calls for an additional cost.

The challenge when applying energy harvesting to sensors is that the energy obtained from energy harvesting is still unstable at present.

The remote-control switch for lighting only needs to be driven when pressed, so there is no need to worry about running out of power when needed. However, the sensors used for monitoring need to transmit the sensed information on a regular basis, so there is a possibility that sufficient power cannot be obtained when needed. As a solution, it is necessary to develop a sensor with lower power consumption, and of course, a method for combining other technologies to achieve an optimal design.

### III. IOT System

Figure 23 shows the block diagram of an IoT system with Energy Harvesting. The components of the system are Transducers corresponding to the specific form of energy, Energy Storage device (battery/Super-capacitor), Power Management Unit (PMU), Sensor devices, Micro Controller Unit (MCU), and Transceiver for communication.

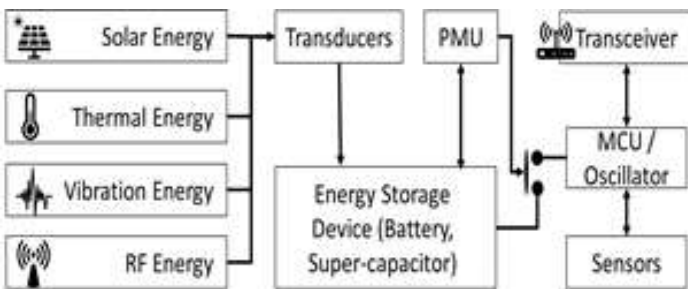

Fig. 24: Block Diagram of IoT system with Energy Harvesting

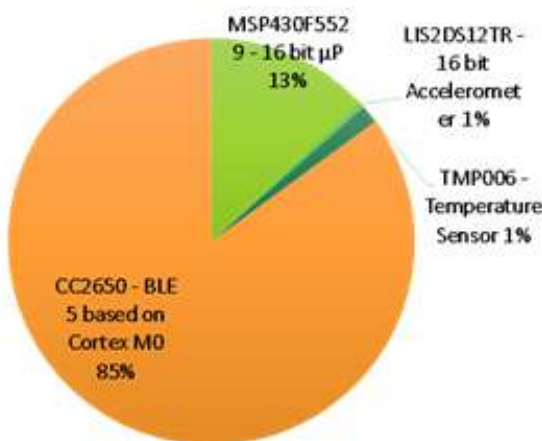

Figure 24 shows the active mode power consumption of the components of the system with a temperature sensor, accelerometer, MSP430F552 microprocessor, and CC2650-BLE 5 based Cortex M0 modules.

The lifetime of the system running on a battery with a rating 40mAh is around 27 days. Through harvesting energy from multiple sources, considering the scaled power densities the battery life is extended by 12 days considering the energy harvested from Solar- 100 $\mu$ W, Thermal - 40  $\mu$ W, Piezo - 10  $\mu$ W, and RF - 0.1  $\mu$ W. IoT system with energy harvesting would have a lifetime of 40 days as shown in Figure 25.

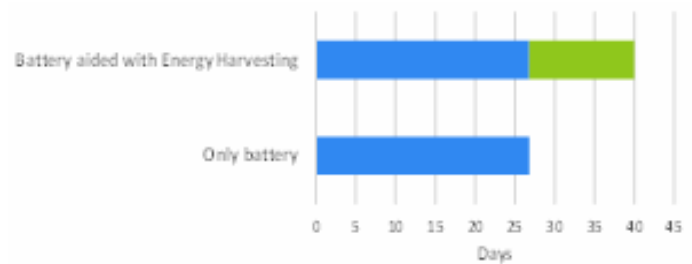

Fig. 26: Life-time extension with Energy Harvesting

It is possible to provide a stable power supply to sensors by properly combining other technologies with energy harvesting. This will make it possible to perform sensing closer to real-time even in cases where real-time sensing has not been possible so far. Building such a sensor network is only feasible through the efficient use of an energy harvesting scheme for optimum power management.

### IV. IOT System with Energy Harvesting

IoT systems can obtain power by harvesting, storing, and utilizing a small amount of energy from external sources (for example, solar, light, heat, kinetic energy, etc.).

#### A. Solar Energy Harvesting

Energy harvesting that collects (harvesting) light energy (energy) from lighting such as sunlight, incandescent lamps, fluorescent lamps, and LEDs to obtain power is called photovoltaic power generation. The biggest feature of photovoltaic power generation is that the energy source is inexhaustible and clean. The power generation efficiency of photovoltaic power generation is almost constant regardless of the scale of the system to be installed. Since it does not generate noise or emissions during power generation, it can be installed anywhere if the amount of solar radiation can be secured.

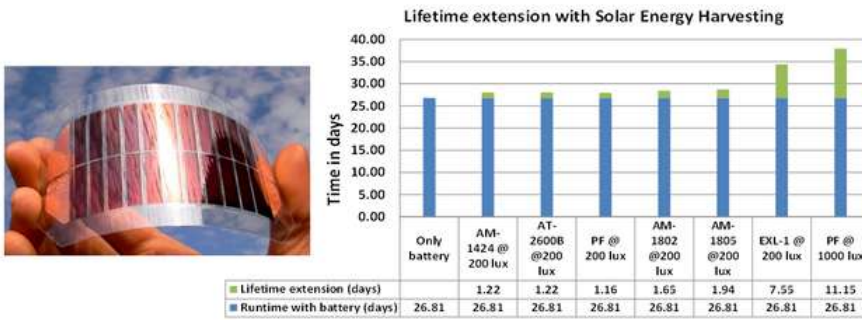

Fig. 27: Lifetime extension with different PV transducers on IoT System

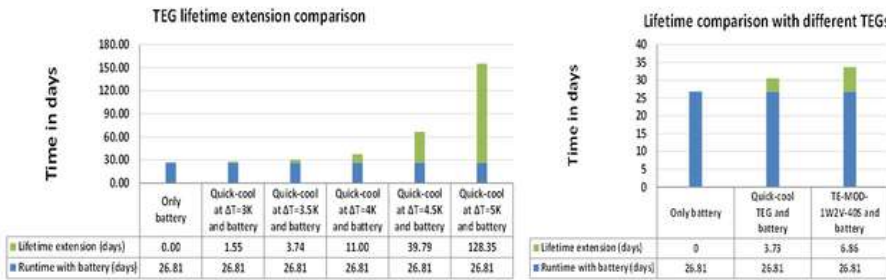

Fig. 28: Lifetime extension for different temperature difference and different TEGs on IoT System

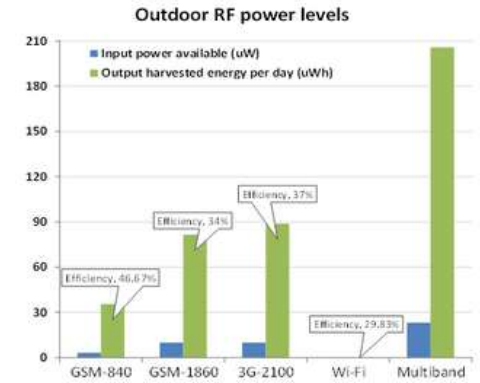
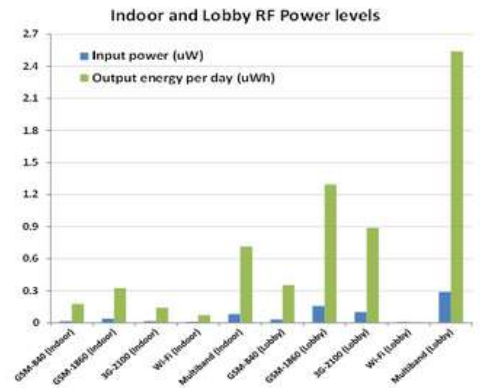

Fig. 29: RF power levels for indoor & outdoor environments

Due to the structural simplicity of the PV system, the life of the system is relatively long. Solar cell modules are readily available, easy to use, and inexpensive. The current and voltage generated is proportional to the cell configuration (series or parallel), module size, and changing ambient illumination. For different PV sources commercially available, the lifetime extension on the IoT System mentioned in Section III for illuminance of 200 LUX & 1000LUX is shown in Figure 26.

### B. Thermal Energy Harvesting

Thermoelectric power generation is a technology that directly recovers electric power energy from waste heat and unused heat. Since there are no moving parts, there is an advantage that vibration does not occur, the life can be extended, and installation is space-saving. Focusing on the fact that there are few factors, and it is possible to supply stable power.

When a temperature difference is applied to a substance (conductor) that easily conducts electricity, such as a metal or a semiconductor, a voltage (thermal electromotive force) is generated across the substance.

The thermoelectric effect is the mutual influence of this thermal energy and electrical energy, and one of them is a phenomenon called the "Seebeck effect" in which the temperature difference between two junctions is directly converted into a voltage.

Recent progress in thermoelectric materials (materials that convert thermal energy into electrical energy and are the core of 3. thermoelectric power generation) makes it a suitable candidate is very promising and can be widely used for energy harvesting technology. For different temperature differences and different commercially available TEGs, the lifetime extension on the IoT system mentioned in Section III is shown in Figure 27. A TEG module can generate respectable amounts of voltage using the human skin as a heat source. The thermal resistance of the body can be significantly decreased by placing the TEGs in the locations on the skin, where the largest heat flows are available. So, putting the TEG near the artery with heated blood decreases the thermal resistance between the human body and the device.

### C. Radio-Frequency RF Energy Harvesting

RF Energy Harvesting can collect small amounts of ambient energy to power wireless devices, and it can be used anywhere, anytime. For this reason, it is a very promising technology for applications where batteries are impractical.

Figure 28 shows the harvested energy power levels by harvesting different ambient frequency bands like GSM, 3G, and Wi-Fi under indoor and outdoor environments. Through multi-band harvesting the effective output power levels are high.

### D. Multi-source Energy Harvesting

For an IoT system to run autonomously the harvested energy should be more than the energy consumed at any instant of time. It is evident that different energy sources have different harvested power densities, hence by considering multi-source harvesting the system can generate sufficient energy to become near battery-free or totally autonomous.

For the IoT system with a battery life of close to a month, through harvesting sufficient energy by selecting transducers accordingly the IoT system can be near battery-free/autonomous. In the multi-source harvesting, the PV panel area is considered as 8.8 cm<sup>2</sup> with an illuminance of 1000LUX for 18hrs a day, the TEG considered has an area of 0.8cm<sup>2</sup> with a temperature difference of 3.5 Kelvin, and a multi-band RF energy harvester as shown in Figure 29.

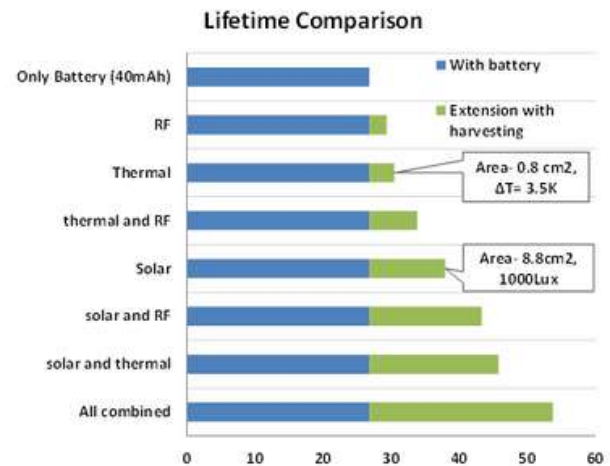

Fig. 30: Lifetime extension from multi-source energy harvesting

### V. Summary

Energy harvesting technology, which has the potential of being ultra-compact, low-cost, lightweight, and flexible, will become an important basic technology to implement cyber-physical systems with various sensors and communication devices. Utilizing our team deep-tech expertise and passion for chip development, we at Green PMU Semi focus on the development of innovative Full-custom Energy-Scavenging and Power Management IC/IP Solutions for 'IoT Edge Devices'.

Energy harvesting technology, which has the potential of being ultra-compact, low-cost, lightweight, and flexible, will become an important basic technology to implement cyber-physical systems with various sensors and communication devices. Utilizing our team's deep-tech expertise and passion for chip development, we at Green PMU Semi focus on the development of innovative Full-custom Energy-Scavenging and Power Management IC/IP Solutions for 'IoT Edge Devices'.

# Alumni's Diary

## Never Give-up

Dr Raghu Piska

PhD 2020 (Civil Engineering)

Current Affiliation: Assistant Professor, BITS Pilani, Hyderabad Campus

KID: 20210317



Hi,

This is Raghu Piska. I have finished my PhD in the year 2020 from the Civil Engineering department. I am currently working as an assistant professor at the BITS Pilani Hyderabad campus. I have also recently received the DST INSPIRE faculty fellowship from the Government of India.

### What made me join IIT, Hyderabad?

IIT Hyderabad is known for its innovative curriculum, state-of-the-art infrastructure, laboratories, and highly qualified faculty. I especially enjoyed the course Finite Element Analysis given by Prof Amirtham Rajagopal. There is no course which I did not enjoy.

### Activities you were involved in?

I was part of the mess monitoring committee during the year 2018-2019. I also participated in the Inter-IIT sports meet in the table tennis category held at IIT Bhubaneswar in the year 2019. I was also a core member of volunteers who organized the International Conference on Composite Structures during the year 2017 which attracted more than 600 participants all over the world

### Specialized training have you had?

At IITH, I was fortunate to attend the GIAN course on Advanced Finite Element Analysis and a workshop on Nonlocal Mechanics given by Prof JN Reddy from Texas A&M University. I have acquired the required skillset at IITH to get a job in academics. The in-depth concepts taught in each subject, mathematical, programming skills, the competitive culture at IITH made me prepared for my current job.

### Best moment from your's life @ IIT Hyderabad?

The day when my code worked!

### The message you want to convey to the existing student folk @ IIT, Hyderabad?

Be prepared to face the challenges and never give up.

### Best about IITH and suggestion for improvement

Well-qualified faculty is something that is the best at IITH. Improvement in sports facilities will be an area where IITH should work on.

### Best way to contact you?

raghupiska@gmail.com

# Alumni's Diary

## Thermoelectric Energy Harvesting: Concept, Challenges, and Technology

Dr Swapnil Ghodke,

MTech-2013, Department of Materials & Metallurgical Engineering

Post-Doctoral Researcher, Center for Low-temperature Plasma Sciences (cLPS)

Nagoya University, Nagoya, Japan

KID: 20210318

### Introduction

Electrical energy plays an essential part in modern human society. The energy is generated by consuming nonrenewable resources, which on the contradictory is also responsible for releasing greenhouse gasses into the atmosphere. Greenhouse gases can hamper the ecological balance by disrupting the ecosystem through global warming and climate change.



The imbalance in demand and supply of these limited energy resources also forecasts a global energy crisis for the future generation. The solution to the above problems lies in alternative energy resources and/or new technologies with higher efficiencies of energy conversion.



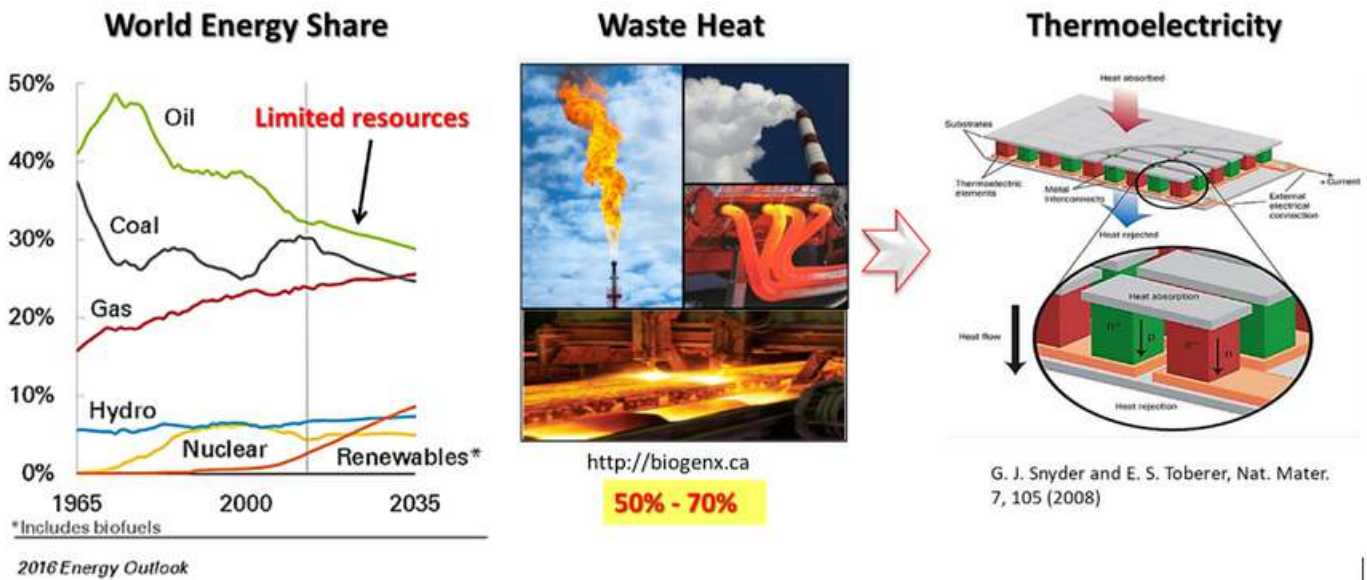

Fig. 31: Consumption of nonrenewable resources for global energy need, waste from of energy in heat, and TEG and energy harvesting technology. <https://www.ogj.com/articles/2016/02/bp-fossil-fuels-remain-dominant-form-of-energy-through-2035.html>

### Concept

Thermoelectric generators (TEGs), solid-state devices that can convert waste heat into useful electrical energy and vice versa without any moving mechanical parts or fluids, are emphasized as one of the potential technologies to reduce the carbon footprint and utilize the energy resources more efficiently.

The concept is very simple when a temperature difference is applied to a substance that easily conducts electricity, such as a metal or a semiconductor, a voltage (thermal electromotive force) is generated across the substance. The thermoelectric effect is the mutual influence of this thermal energy and electrical energy, and one of them is a phenomenon called the "Seebeck effect" in which the temperature difference between two junctions is directly converted into a voltage.

The efficiency energy conversion in TEGs is an increasing function of the dimensionless figure-of-merit,

$$\eta = \frac{T_H - T_C}{T_H} \frac{\sqrt{1 + ZT} - 1}{\sqrt{1 + ZT} + \frac{T_C}{T_H}}$$

Here,  $T_H$  and  $T_C$  represent the temperature of the hot end and cold end,  $ZT = S^2 \sigma T \kappa^{-1}$ , where  $S$ ,  $\sigma$ ,  $T$ , and  $\kappa$  stand for the Seebeck coefficient, electrical conductivity, absolute temperature, and thermal conductivity of constituent thermoelectric materials, respectively. The efficiency of energy conversion in TEGs is directly proportional to electrical conductivity and Seebeck coefficient while inversely to thermal conductivity.

### Challenges and strategies for High-Performance Materials

A high-performance thermoelectric material should possess a high power factor  $S^2\sigma$  along with low lattice thermal conductivity. This means a material must be a good conductor of electricity and a poor conductor of heat. Theoretically, all the physical quantities are strongly coupled with each other, which makes it more challenging to obtain a high-performance thermoelectric material. Since the early 1900s, extensive research has been carried out for obtaining high-performance thermoelectric materials found out that semimetals could be used for practical applications by improving their thermoelectric properties through novel strategies.

Such as reducing lattice thermal conductivity through grain boundary scattering, nanostructuring, composite effect, quantum dot superlattices, amorphous structures, modulation doping, and nanoporous structures.

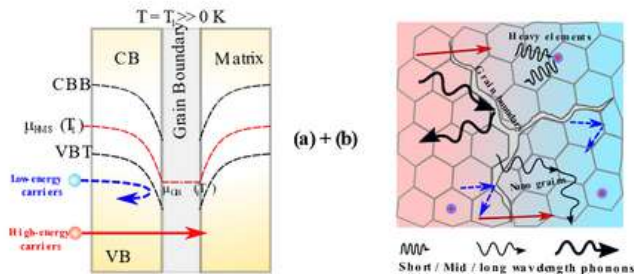

Fig. 32: Strategy of energy filtering and phonon scattering strategy for high-performance TEG [Ghodke et al. ACS Appl. Mater. Interfaces 2019, 11, 34, 31169–31175]

Numerous state-of-art thermoelectric materials have been reported with ZT more than unity in different temperature range; SnSe (ZT = 2.6), Pb-Te (ZT ~ 1.8), Bi-Sb-Te (ZT ~ 1.86), Zn-Sb (ZT ~ 1.3), Cu<sub>2</sub>Se (ZT > 2), Mg<sub>2</sub>Si (ZT ~ 1.3), TAGS (ZT ~ 1.5), MnSi (ZT ~ 1.15). Using these materials, the equivalent efficiency of energy conversion from waste heat to electrical energy in practical applications varies in the range of 5% to 15% depending on the applied temperature range.

**Teg Applications: Mars Rovers to IoT Devices**

TEGs became very famous when NASA in the 1970s utilized this technology in radioisotope thermoelectric generators for deep space missions and interplanetary explorations (Mars rovers). Along with technological advancements, TEG technology has been used for energy harvesting in automobiles, power plants, or industries.

In recent years with the growth of IoT devices and wireless technology, TEGs have come into use for day-to-day life applications in form of wearable battery-free devices. Here, the human body heat as a source is used to generate electric power for such devices as digital watches, health monitoring patches, etc. Autonomous power sources for sensors generally do not require large amounts of power and can be sustained from ambient sources with a stable power supply, solely on TEGs.



Fig. 34: An overview of wearable thermoelectric generator and applications. [Adv. Mater. 2021, 2102990]



ATEG\_Tested concept by BMW corporation / [www.bmw.com](http://www.bmw.com)



US Department of Energy/[www.energy.gov](http://www.energy.gov)

Fig. 33: TEG concept tested for efficient exhaust in automobile by BMW, and RTEG used by NASA for Mars Rover



# Alumni's Diary

## Alumni Seminar Series @Department of MSME

Dr Swapnil Ghodke (R)  
 MTech, 2013, Post-Doctoral Researcher,  
 Center for Low-temperature Plasma Sciences (cLPS)  
 Nagoya University, Nagoya, Japan,  
 Ms Monica Singhal (L)  
 PhD Scholar

Department of Materials & Metallurgical Engineering

KID: 20210319

### Piezoelectric material helps in the detection of Breast cancer: an expert said at an event held at IIT Hyderabad

Recently, breast cancer has been a growing health concern across the globe. Dr. Karthik Thangavelu at an event held at IIT Hyderabad said that a thermal sensor-based device working on the principle of piezoelectric material has been developed for screening breast cancer at the Centre for Materials for Electronics Technology (C-MET), Kerala.

The pandemic has brought crisis but has also given an opportunity with digital platforms to connect people without any geographical limitations. This time, the faculty of the MSME department and Dr. Swapnil Ghodke, an alumna of IIT Hyderabad have taken an initiative to organize its first alumni seminar series which aims to connect alumni, students, and faculties on a digital platform discussing significant technical issues and advancements. This seminar is expected to happen once every three months, and in its first phase, there will be seven alumni seminar meets. In every seminar, one alumni speaker will share his views on his area of expertise. 7 alumni Dr. Karthik T (India), Dr. Dan Sathairaj (India), Dr. Pankaj Sahlot (India), Dr. Kanwal Chadda (Canada), Dr. Elango Chandiran (Japan), Dr. Zaid Ahmad Mohammed (Czech Republic), and Dr. Swapnil Ghodke (Japan), the prominent scientists in their respective fields have volunteered to be part of its first phase.

The inaugural event was held on 18th September 2021 which was attended by 65+ alumni, students, and faculty members of the MSME Department.

Dr Karthik T has presented a seminar on "Piezoelectric Materials and Devices: A technological perspective". Dr Karthik's talk covered the brief activities of C-MET Thrissur with a strong emphasis on the piezoelectric based devices and the importance of the materials design, processing of the piezoelectric actuators and devices for defence and space was discussed. The talk also emphasized the need for indigenous piezoelectric based devices for the country's strategic and commercial requirements. Along with it another highlight of the event was the "Panel discussion & student session" where current PhD students and alumni discussed the challenges faced during PhD and opportunities after PhD in different fields.

Certainly, this event has given an opportunity for alumni and students to discuss the ongoing technological trends which will further help the current students to upgrade their skills. It has also provided a chance for alumni to interact with their former teachers and helps the alumni to notice the various changes through which the college has gone through over the past few years.



Fig. 35: Participants during the session

2020 Excellence in Academics awardee message for PhD Scholars



**Dr Bhavesh Garg**

PhD, Department of Liberal Arts,  
IIT Hyderabad (2018)  
Assistant Professor, Economics  
Dept. of Humanities & Social Sciences  
IIT Ropar

Things have been strenuous for everyone in the troubling present, especially for the research scholars. Almost everything is virtual, be it seminars, conversations with friends, or learning; there is an apparent loss of moral support we always seek from our peers in this lone PhD journey.

Of late, the job market is severely affected due to the current crisis. Hence, it is all the more important that the near-graduating scholars are more careful about their mental health and view the current situation as a temporary constraint.

It is vital that we become a source of strength for each other to get over these grey days and emerge stronger.

"Excellent Services to the National Programs 2020" awardee message



**Mr. Pranay Ramesh Patil**

BTech, Electrical Engineering,  
IIT Hyderabad (2013)  
Consultant to the Asian Development Bank

"The current pandemic has shown us that robust technological solutions can significantly aid our fight against the coronavirus.

I'm very happy to see the IITH community working actively towards building solutions for mitigating COVID-19. I want to urge the IITH fraternity to utilize the same zeal and enthusiasm to ideate, invent and innovate for other emerging needs during these trying times.

The future generations of the country shall look up to us as torchbearer technologists who turned this calamity into an opportunity. I'm most confident in the capabilities of the IITH Family, and I'll be happy to support the efforts in any possible way."

"Excellence in Academics" awardee message



**Dr Dan Sathiaraj**

PhD, Material's science and Metallurgical  
Engineering, IIT Hyderabad (2016)  
Assistant Professor,  
Department of Mechanical Engineering,  
IIT Indore

The current pandemic situation has changed our student's everyday life imposing unprecedented educational changes. The temporary university closures have affected our educational system and placed substantial mental stress on students and professors.

Nowadays, staying motivated can be difficult for many students. It is okay to expect less from yourself right now. Staying motivated, mentally healthy, and positive attitude can help refocus our thoughts away from these difficult times and towards a prosperous future.

Let Us Fight the Global Pandemic Together!!!

IIT Hyderabad Congratulates...

**Dr K T Hafeez,**  
VP Engineering, Green PMU Semi Pvt Ltd  
&

**Dr R Sai Chandra Teja,**  
Chief Operating Officer, COO, Green PMU Semi Pvt Ltd

For their startup selection into

1st Cohort of "Semiconductor Startup  
Incubation & Acceleration Program" by  
NxP Semiconductor and FabCI IIT  
Hyderabad



Dr K T Hafeez  
MTech '2011 & PhD '2021, Dept. of EE



Dr R Sai Chandra Teja  
MTech '2012, Dept. of EE

IIT Hyderabad Congratulates...

**Ms Maitrayee Tiwari**

MSc, 2013-2015  
Department of Physics

for receiving the

Postdoctoral Scientist Prize for  
Excellence - 2020-21



Testimonies & Recognitions

# Incubatee's Diary

## Activities by iTIC Incubator at IIT Hyderabad

Venu Rathore, Consultant (R)  
Keyur Punjani, Manager - Programs (L)  
i-TIC Incubator)

KID: 20210320



iTIC Incubator has been upgrading itself in the various verticals: rebranding, structured mentoring support, prototyping facilities, etc. For any startups to get support from the incubator, iTIC has defined entry points as:

### Pre-incubation

For idea-stage entrepreneurs, iTIC has a structured pre-incubation program of 12 months. This program aims to support entrepreneurs convert their ideas into working prototypes.

### Incubation

For the startups that have a prototype or an MVP, iTIC has a structured incubation program of 24 months. This program aims to support startups, convert their prototypes into sellable products and gain traction.

A glimpse of some of the activities conducted and programs managed can be given a quick read below.

### Events organized BHUMI Roadshows

iTIC Incubator along with MeitY and BSF organized virtual roadshows across India to sensitize the entrepreneurs and startups for the BHUMI Grand Challenge (BSF HIGH-TECH UNDERTAKING FOR MAXIMIZING INNOVATION). The Grand challenge focused on solving issues pertaining to BSF and defense organizations across the country. The Challenge offered total financial aid of INR 1.65 crores.

### About BHUMI Challenge

The proposed Grand Challenge had four pre-identified problem statements that try to tackle challenges relating to:

- 1) Detecting presence of electronic devices
- 2) Tunnel or underground activities
- 3) Lack of alternative communication systems directly affecting the efficacy of the operations in shadow areas and
- 4) Anti-drone technology to stop the menace of Drones for Narco-Terrorism and attack on Vital installations.



Fig. 36: Bhumi Grand Challenge Announcement

### Structured Mentor sessions

#### Session 1: Entrepreneurship Mindset

Date: 16th August 2021

Program: Expert Session

Speaker: Parminder Singh, Chief Information Officer - India, Guardian Life

**About the program:** The main aim of this interactive session was to enable the early-stage startup founders with the mindset required to start and run a company. This session was attended by 15 of our startups

**About the Speaker:** Parminder Singh is a seasoned IT professional and has over 30 years of experience delivering business outcomes through technology projects with strategic & leadership qualities. He has worked with marquee companies in America, India & Australia. He is currently the CIO for India at Guardian Life Insurance company of America. Parminder has rich experience in Manufacturing, Outsourcing & Offshoring industries. He has worked in the Retail, Real Estate, Hospitality, Pharmaceutical, and Financial services industries. Parminder has been a visiting faculty to educational institutions like IIT Delhi, Symbiosis School of Management Pune, Jaypee Business School, and Amity University in Noida.

### **Session 2: Setting KPIs, OKRs, goals and tracking progress**

Date: 23rd August 2021

Program: Interactive session

Speaker: Prashant Pansare, Head of India, Airmeeet

**About the program:** The main aim of this interactive session was to enable the early-stage startup founders to help them in planning their KPIs, OKRs, and setting goals. This session was attended by 19 of our startups.

**About the Speaker:** Prashant is a 4x Entrepreneur, Problem Solver, and Go-getter. He has built multiple startups from the ground—expert on bootstrapping, growth hacking, business growth, and Angel Investing. Usually, the go-to man when things do not move or needs an innovative approach, be it engineering, product, customer service, business, marketing, or anything required to meet business growth.

He has built Eagle10 Ventures, Medissist, OnlinePrasad, Playerify, and Startup Leadership Program India. Earlier, he had a corporate life & was a strong hands-on technical leader working for various global products in the Digital TV Space in India, China, and Europe.

### **Session 3: Design Thinking Workshop**

Date: 30th August 2021

Program: Workshop

Speaker: Anay Mashruwala

**About the Program:** The main aim of this workshop was to enable the early-stage startup founders to help understand the Design Thinking process - which aims to radically change how to solve a problem by diversifying the design team and fully understanding a specific user. Design Thinking provides a structured process that helps innovators break free of counterproductive tendencies that thwart innovation. This session was attended by 15 of our startups.

**About the Speaker:** Anay Mashruwala has taken over the mantle of a 4 generation old organization serving the needs of the decades-old cloth client's every changing need by continuously upgrading the know-how and skill set. He has been in the founding team of PDPU IIC where Startups groomed by them have filed for more than 150 IPRs; created employment for more than 3500 people, and won more than 200+ national international awards since 2016.

He has also taught Entrepreneurship and Innovation to the fraternity of NID, IIT Mandi, IIT Hyderabad, IIM Ahmedabad, IIT Delhi, KEIO University Japan, Yokohama University Japan, and trained Entrepreneurship Educators from across the globe.

**Program updates**

**TiHAN startup support**

iTIC Incubator invited startups for TiHAN Pre-incubation (PRAYAS/EIR) and TiHAN Incubation programs. TiHAN startup program supports entrepreneurs and innovative startups working in the field of Autonomous Navigation and Data Acquisition Systems (UAVs, ROVs, etc). The financial aid under the PRAYAS/EIR program is up to INR 10 Lakhs and up to INR 25 Lakhs under the incubation program. iTIC shortlisted

S. No.	Startup Name	About the startup
1.	UAVIO Labs	UAVIO Labs aims to create sentient drones capable of making smart decisions while performing tasks in the real world autonomously.
2.	Rovonize	Rovonize systems focuses on building state of the art surveillance aircrafts and copters with a wide range of civilian & military applications. Their products range from multicopters to full scale fixed wing aircrafts.
3.	Qoptars	Qoptar is a drone manufacturing startup building the finest drones for videography and photography
4.	Alog	Alog is a deep tech startup developing autonomous systems to improve productivity in logistics, retail and manufacturing.
5.	Adiabatic	Adiabatic aims to develop an innovative passive thermal cooling solution for li-ion battery packs to increase its life, performance & safety.

**MeitY TIDE 2.0**

MeitY TIDE 2.0 is a scheme launched by the Ministry of Electronics and Information Technology to support startups working in the ICT domain. Under the TIDE 2.0 program, entrepreneurs are supported by providing financial aid of up to INR 7 Lakhs. iTIC Incubator invited applications under this program and has shortlisted 3 promising startups for this year.

S. No.	Startup name	About the Startup
1.	Urban Brain	UrbanBrain is building AI-powered smart traffic light systems to tackle congestion in Indian Cities.
2.	Medsamaan	The aim of the idea is to measure the height and weight of a child below 2 years of age to track growth by photographs.
3.	Puzzoku	The idea is to monitor the health of a child below 2 years of age from photographs.

**TiHAN-IIT Hyderabad**  
NextGen Autonomous Navigation

**iTIC Incubator**  
IIT Hyderabad

**inviting application for TiHAN Incubation program**

The objective of this program is to support prototype stage startups in the field of **Autonomous Navigation and UAVs.**

Registration link:  
<http://bit.ly/incubation-at-itic>

Deadline to apply:  
June 15, 2021 at 6:00 pm

For any queries, please contact us on: [office.itic@iith.ac.in](mailto:office.itic@iith.ac.in) or +91 93983 23668

**TiHAN-IIT Hyderabad**  
NextGen Autonomous Navigation

**iTIC Incubator**  
IIT Hyderabad

**inviting application for TiHAN PRAYAS/EIR program**

The objective of this program is to support idea stage entrepreneurs convert their ideas into working prototypes in the field of **Autonomous Navigation and UAVs.**

Registration link:  
<http://bit.ly/preincubation-at-itic>

Deadline to apply:  
June 15, 2021 at 6:00 pm

For any queries, please contact us on: [office.itic@iith.ac.in](mailto:office.itic@iith.ac.in) or +91 93983 23668

Fig. 37: TiHAN Program Announcement

# Incubatee's Diary

## Startup at iTIC - BluPower

Upamanyu Ghosh  
 Founder, BluPower  
 KID: 20210321



# BLUPOWER



**Establishment Date:**  
 April 18, 2020

**Number of Team Members:**  
 2

**About the Business:**  
 Blupower's is in scaling of distributed & decentralized hydropower solutions that produce reliable renewable energy, which are climate resilient, and balance the competing demands on water through a combination of innovative hardware design and AI.

**Founding Member/s:**  
 • Upamanyu Ghosh, Founder

**Problem Statement:**  
 Having renewable energy or energy in the first place is not a certainty in large parts of the world. Hydropower is identified as one of the cheapest ways of providing the energy to communities, but it has some drawbacks. The technology mostly needs larger infrastructure and often floods valleys, disrupting the local ecosystem and the lives of those it should be helping. Hydropower is also not scalable, making it more expensive than it needs to be

**Products or Services:**  
 Blupower is a clean-energy company developing vortex hydro plant for low-head rivers or canals sites that remained unfeasible up till now for electrification. In comprehensible terms: this means that water flows with minimal height difference, from 1- 10 metres, can now be used to generate energy through our vortex hydro plant

**Value Proposition:**  
 A predictable and cost efficient hydropower plant with an LCOE <\$0.03/kWh. Uniquely designed to limit complexity civil works, logistics, installation requirements and maintenance, and to be neutral to fish, debris and sediments without extra structures. With a global small hydropower potential of 217GW, a huge impact in energy generation can be achieved with smart, decentralized hydropower.

**Key Highlights:**

- Winner of social Alpha Energy Challenge 2.0
- One of 98 selected youth projects from around the world - Youth Sustainable Energy Hub
- 2- Patents Applied

**Target Market:**  
 Governments | Renewable Energy Utilities | Rural Population| SMEs

**Current Stage of Startup:**  
 Prototype



**BluPower** is a hydropower startup with the aim of developing hydropower projects to help generate renewable energy. They plan to tap into the international market especially in Europe, Australasia, and African countries. In Indian, they wish to start by developing watersheds in drought-affected areas and use the runoff water to generate renewable energy using their hydro-engines. This energy may be utilized for irrigation purposes, charging batteries, or for powering nearby hydrogen synthesis plants enabling indigenous production of green hydrogen in India. While on one hand watersheds will help in recharging the groundwater, BluPower's hydropower module will generate clean electricity thus enabling a carbon-neutral economy.

By 2030, BluPower hydro solution will produce reliable and clean energy globally, amounting to 8,000 GW.hr of energy annually that impacts 20 million lives in grid deficient communities.

At present we have developed a proof-of-concept and have received initial grants for developing our Minimum Viable Product. We have manufactured the turbine which is to be tested in Indian labs for further upgradation in future models.

We shall be limiting their generation capacity to less than 25 MW in India as in 2015, the Indian government stopped categorizing hydel projects larger than 25 MW as renewable.

We have found new innovative applications of their product in thermal power plants which shall help increase the overall efficiency of the same. We are also contacting independent project developers for developing a product specific to their needs especially for rural areas where the grid is unreliable.

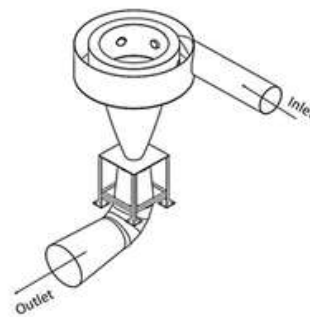

Fig. 38: BluPower Turbine

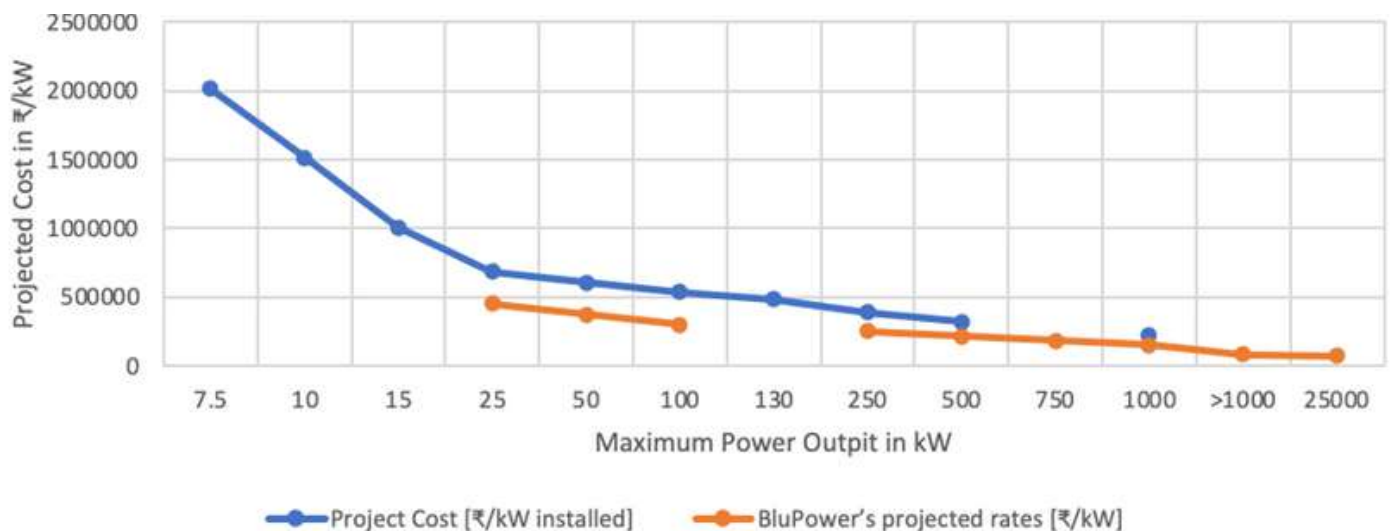

Fig. 39: HydroPower Systems - Cost to Build

# IIIT Raichur's Diary

## Q3 update from IIIT Raichur

भारतीय सूचना प्रौद्योगिकी संस्थान रायचूर  
Indian Institute of Information Technology Raichur

On the occasion of  
**National Doctor's Day**

**DR. VIJAYSHREE AGRAWAL**  
BHMS, CHC  
A university Gold Medalist.  
Expert in Homeopathic Medicine and surgery.  
Ex-Resident Doctor, GHMC, Bhopal.  
Private Practitioner: Yash Homeopathic Clinic, Bhopal.

IIIT RAICHUR WELCOMES EVERYONE FOR OUR VIRTUAL CELEBRATIONS AT 4:30 p.m.

The session will be live on our youtube channel.

1st July

in @t f y

Despite the dire circumstances that prevailed across the world, doctors in India fought selflessly to serve mankind. IIITR has organized a virtual event on National Doctor's Day, where Dr. Vijayshree Agarwal has shared some insight into the current health crisis.

View the session at:  
<https://youtu.be/fRk7PH6U25A>

IIIT Raichur is an emerging premier institution in the field of CS & IT under the mentorship of IIT Hyderabad. The Training and Placement Cell at IIIT Raichur has declared its first Internship Season open for esteemed organizations for the Internship Season 2021-22. Companies Can register at:  
<https://forms.gle/c8aXW35ay6L34Dro9>



2021 - 22

Training and Placement Cell  
We're Ready for Internship, are you..??

Training and Placement Cell of IIIT Raichur cordially invites for the Internship Season 2021 - 22.

Register your company with us at:  
[tnp.iiitr.ac.in](http://tnp.iiitr.ac.in)

Contact us:  
Call: +91-8768779475  
or  
Mail: [tnp@iiitr.ac.in](mailto:tnp@iiitr.ac.in)/  
[fic.placement@iiitr.ac.in](mailto:fic.placement@iiitr.ac.in)



This August 15, IIIT Raichur celebrated its 1st Independence in the new Transit Campus along with the Faculty Members & Support Staff at GEC Raichur

# IIIT Raichur's Diary

## Q3 update from IIIT Raichur

To celebrate the birth anniversary of Dr Sarvepalli Radhakrishnan, Certificates of Academic Excellence were given to the best performers of each academic year by Prof B S Murty, Director of IIT Hyderabad & Mentor Director of IIIT Raichur, in presence of IIITR's inspirational faculty and passionate students.

View the event at:

<https://youtu.be/W4tjc78L4s4>

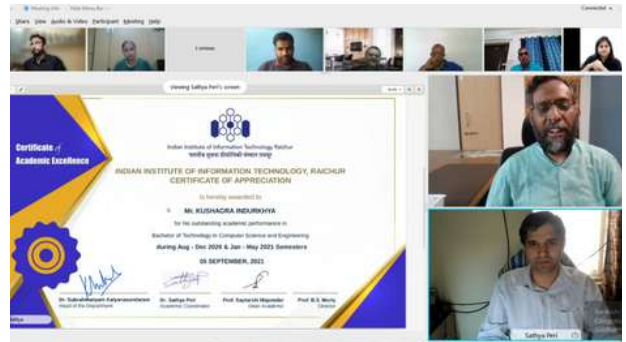

#TheSuccessSaga

IIIT Raichur Congratulates...



**Ananya Mantravadi,**  
a student of CSE'23 batch

for being selected as the

**Lead for starting a  
Google DSC at the  
campus**

Ananya Mantravadi  
General Secretary  
Student Gymkhana, IIITR

IIIT Raichur is proud to share that Ananya Mantravadi, a student of the CSE'23 batch has been selected as the Lead for starting a Google DSC at the campus. Google Developer Student Clubs are university based community groups for students interested in Google developer technologies.

IIIT Raichur congratulates Siddharth Saini (2nd year, CSE), whose work at CKM Vigil Pvt Ltd as an ML Intern, along with the team led to the recognition at a National Level Project Competition - Innovation in Manufacturing Processes (IMP 2021)

भारतीय सूचना प्रौद्योगिकी संस्थान रायचूर  
 Indian Institute of Information Technology Raichur

#theSuccessSaga

IIIT Raichur congratulates CKM VIGIL Team for getting

## 2nd Prize

in Startup Category at

### Innovation In Manufacturing Processes (IMP) 2021

NatFoE 2021 organised by INAE & IIT Hyderabad

**C KRISHNA MOHAN**  
Founder & Director  
CKM VIGIL Pvt Ltd  
(Mentor)

**R SAI CHANDRA TEJA**  
Founder & Director  
CKM VIGIL Pvt Ltd  
(Mentor)

**C VISHNU**  
PhD Research Scholar  
IIT Hyderabad  
(Mentor)

**SIDDHARTH SAINI**  
B.Tech CSE, IIIT Raichur

**DIVYANSH KUMAR**  
B.Tech. ECE, IIIT Nagpur

**ROHIT CHINTALAPUDI**  
DD ME, IIT Bhubaneswar

**SIDDHANT KAPSE**  
DD MME, IIT Kharagpur

# IIIT Raichur's Diary

## Q3 update from IIIT Raichur

IIIT Raichur Congratulates...

**Ms Mitalee Agrawal**

Public Relations Officer, IIIT Raichur

for Being awarded Jury Special

Chanakya Award 2021 as the  
Social Media Person of the Year  
by Public Relations Council of  
India (PRCI)



IIIT Raichur congratulates Ms Mitalee Agrawal, Public Relations Officer, IIT Hyderabad & PRI-in-Charge, IIIT Raichur for being awarded the jury special Chanakya Award 2021 as the Social Media Person of the Year by Public Relations Council of India (PRCI).

Council of Student Affairs, the student body of IIITR, conducted a small & interactive career guidance session with the IITH & IIITR faculties. The session focused on providing guidance to the students about the significance of time and attaining in-depth knowledge.



PRESENTING  
**GDSC IIIT RAICHUR**  
CORE TEAM

 Ananya Mantravadi GDSC Lead	 Reethu Sanagala Marketing & PR	 Suhani Kalra Media & Content	 Kaushtubh Kesharwani Design & Creatives
 Aditya Agrawal Cloud	 Kushagra Indurkha Open Source	 Siddharth Saini AI/ML	 Abhijeet Wankhade Flutter
 Jatin Sachdeva Web	 Koushik Puppala Frontend		

IIIT Raichur presents & congratulates core members of GDSC at IIIT Raichur. Wish the team a successful journey!



# IITH in News

## Indian Express

Thu, 19 Aug-21; New Indian Express - Hyderabad: Size : 228 sq.cm.; Circulation:31000; Page : 3

### IIT-H, Honeywell to set up an AI lab on campus

EXPRESS NEWS SERVICE  
Hyderabad



THE Indian Institute of Technology (IIT) Hyderabad is prepared to set up an Artificial Intelligence (AI) lab, in partnership with Honeywell Technology Solutions (HTS). The lab was inaugurated on Wednesday by Dharmendra Pradhan, Minister for Education, Skill Development and Entrepreneurship.

During the inaugural event, Dharmendra Pradhan, Union Education Minister, said, "IIT-H is the first institute in the country to offer full-fledged BTech in AI in line with the recommendation of National Education Policy (NEP) 2020. With the recom-

mendation of NEP 2020 such collaboration would become more common."

Additionally, Professor BS Murty, Director of IIT Hyderabad, said, "The young minds at IIT-H are geared up to make the institute feature among Top 500 global institutions soon." Both the institutions have entered into an agreement to establish an Artificial Intelligence (AI) lab for joint research on artificial intelligence and such emerging technologies.

## THE TIMES OF INDIA

Copyright © 2014 Bennett Coleman & Co. Ltd. All rights reserved

Wed, 11 Aug-21; Times Of India - Hyderabad: Size : 141 sq.cm.; Circulation:267065; Page : 2

### mPTX molecule designed by IIT-Hyd could improve chances of successful IVF

TIMES NEWS NETWORK



**Hyderabad:** A new molecule 'mPTX' designed by the Indian Institute of Technology, Hyderabad along with Kasturba Medical College and Manipal researchers can improve sperm quality for in-vitro fertilization (IVF).

With an estimated 48 million infertile couples worldwide, reduction in sperm motility (sperm movement) is one of the major causes of male infertility. Motility is essential for sperm to reach the site of fertilization during natural conception.

Researchers from IIT-H, Mangalore University and the Kasturba Medical College, Manipal, Manipal Academy of Higher Education took up a funded project by the department of science and technology's science and engineering research board

to design the molecule that makes IVF more successful.

The research was recently published in peer-reviewed Journal Nature Scientific Reports. In IVF technology, pentoxifylline is a widely used pharmacological agent for assistive reproduction. Pentoxifylline treatment increases sperm motility which goes hand in glove with the undesirable chemical reactions before fertilization, which together determines the success of IVF.

"The newly designed molecule mPTX, a pentoxifylline derivative, was able to increase sperm motility, prolong in vitro sperm survival, improve sperm fertilization potential, without adversely affecting the development of the embryos at much lower concentration compared to the widely used pharmacological agent-pentoxifylline in IVF technology," said Rajakumara Eerappa, associate professor, department of biotechnology, IIT-H, adding that undesirable chemical reactions before fertilisation are comparatively lesser by mPTX than other pharmacological agents used in IVF technology.

## THE HINDU

Copyright © 2014, The Hindu

Tue, 17 Aug-21; Hindu - Hyderabad: Size : 224 sq.cm.; Circulation:191215; Page : 3

### IITH establishes astronomical observatory on campus

Designed for outreach programmes, says Director Murty

SPECIAL CORRESPONDENT  
BANGALORE

As a first step towards starting astronomical activities as well as a student's training program, a large telescope facility has been established in the Indian Institute of Technology, Hyderabad (IITH) campus. The telescope is equipped with a huge mirror with an optical diameter of 355 mm (second largest among IITs after IIT Kanpur) with a focal length of 1650 mm. Such a large mirror along with a Crayford focuser and elegant truss tube design will enable observation of the deep sky and faint objects which cannot possibly be detected with a small telescope. Small craters on the lunar surface, rings of Saturn are some of the small features that can be resolved with the telescope. An advanced digital camera will be used to record images and transient astronomical phenomena like meteor showers. Although the telescope would primarily aim for the outreach and night sky observational training programs, it has the capabilities of delivering research level perfor-



Director of IITH BS Murty explaining to students the use of the reflector telescope established at IITH in Sangareddy district on Sunday.

mance which will be explored subsequently.

With this Telescope, IITH will be a part of the Indian astronomical community hosting a large telescope for an effective outreach with high-quality deliverance. The project is funded by Director of the IIT Hyderabad BS Murty, and managed by Assistant Professor in the Department of Physics Mayukh Pakari. The facility was inaugurated by Padmalushan award winner B. N. Suresh, Chancellor and Founding Director of the Indian Institute of Space Science and Technology, Thiruvananthapuram.

"The enthusiasm and the curiosity of young students about objects in the sky are limitless. With this large telescope, we will provide them an opportunity to study celestial objects in greater detail than other small telescopes conventionally used for outreach programs. Activities like stargazing training programs, observing astronomical transients, working with celestial images will add to their sense of human connection with space," said Dr Murthy



వంటి హైదరాబాద్లో అధికారులతో చర్చలను, రోడ్ సేఫ్టీ అడిషనల్ డీపీటీ సుబ్బరంజన్ శాండ్స్

### ప్రమాద రహిత రహదారులై లక్ష్యం

రోడ్ల, అగస్టు 24: ప్రమాద రహిత రహదారులుగా సేవనలో హైవేలను తీర్చిదిద్దడమే లక్ష్యంగా మనపైకేసుం రోడ్ సేఫ్టీ అడిషనల్ డీపీటీ సుబ్బరంజన్ శాండ్స్ అన్నారు. మంగళవారం సంగారెడ్డి జిల్లా కేంద్ర మండలంలోని వంటి హైదరాబాద్లో జిల్లా ఎస్పీ రమణమూర్తి, మిసిస్టీ ఆఫ్ రోడ్ ట్రాన్స్పోర్టు హైవే రిజిస్టర్ అధికారి టి.వి.ఎస్.ఆర్. అప్పారావుతో జరిగిన భేటీలో ప్రమాదాల నెలకొనకుండా నివారించుటకు ప్రమాద రహిత రహదారులను ఏర్పరచాలని వంటి హైదరాబాద్ ప్రాజెక్టును పట్టికలో ఉంచాలని వంటి హైదరాబాద్ ప్రమాద నివారణా కమిషన్ -85వ సభలో అధికారులతో చర్చలను, వాటిని గల కారణాలను విశ్లేషించారు. ఇది రహదారులపై అగ్ని ఘాతానికి ఆర్డర్లు, అక్కడ ప్రమాదాలు జరగకుండా ఎలాంటి చర్యలు తీసుకోవాలి, వంటి హైదరాబాద్ అధికారులతో నిర్వహించిన భేటీలో, మోరల్ నిబంధనలు, మోరల్ సెంటిమెంట్లను అధికారులతో వివరించారు. అదేవిధంగా పాఠాధికారులతో చర్చలను జరపడానికి అనుబంధించి ఫెడరేషన్ ట్రీట్, అందరూ పాటించాలని నిర్ణయించారు, వాటిని పాటించాలని నిర్ణయించారు. సుదీర్ఘ చర్చలను ఏర్పరచారు, అందుకు సుబ్బరంజన్ ముందుగా

అనుబంధించి ఫెడరేషన్ ట్రీట్, అందరూ పాటించాలని నిర్ణయించారు, వాటిని పాటించాలని నిర్ణయించారు. సుదీర్ఘ చర్చలను ఏర్పరచారు, అందుకు సుబ్బరంజన్ ముందుగా

- రోడ్ సేఫ్టీ అడిషనల్ డీపీటీ
- సుబ్బరంజన్ శాండ్స్
- రోడ్డు ప్రమాద నివారణా కమిషన్ -85వ సభలో
- సుబ్బరంజన్ శాండ్స్

## THE TIMES OF INDIA

Copyright © 2014 Bennett Coleman & Co. Ltd. All rights reserved

Wed, 04 Aug-21; Times Of India - Hyderabad: Size : 197 sq.cm.; Circulation:267065; Page : 2

### Time right to start reopening: IIT-H prof on Sutra team

Amita Dhyala  
@timesgroup.com

**Hyderabad:** The time is right for start opening up businesses and commercial activity, according to IIT-Hyderabad professor Dr M Vidyasagar who is part of the Sutra team. Sutra is a mathematical model developed by IIT-Kanpur and IIT-Hyderabad to predict the progression of the pandemic. Dr Vidyasagar said that the government should also start thinking about opening schools in the near future.

"Daily wage workers have to work and children have to go back to school. Online is not a substitute for real classes. We need to start discussions on how to reopen, set up a taskforce to plan the process. Not opening up is not going to make the pandemic go (away) any faster," Dr Vidyasagar said.

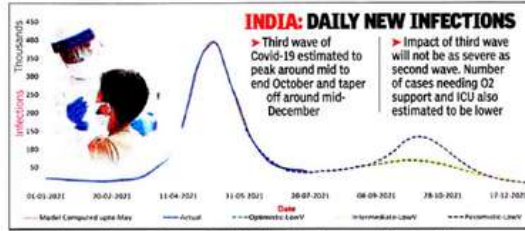

Dr Vidyasagar cited the results from the latest sero-survey by ICMR and a contemporary survey by AIIMS, both of which showed that sero prevalence in children was as high as that in adults. He predicted the third wave to peak around mid to end October. "The second wave is pretty much over in most of the country except

in Kerala and Maharashtra..." the SERB National Science and Distinguished Professor said, adding that the third wave will not be as severe as the second. "The reason it won't be as severe as the second is that most people who were infected in the second wave are still within the 6-month period when they will have the benefit of antibodies."

The outcome of the third wave will also depend on the presence of a more virulent variant of the virus, Dr Vidyasagar said. "As per our mathematical model, in the worst case scenario too, daily average cases will be between 1.2 and 1.5 lakh in the country. The number of serious infections requiring oxygen or ICU will also be lower," he said.

The outcome of the third wave will also depend on the presence of a more virulent variant of the virus, Dr Vidyasagar said. "As per our mathematical model, in the worst case scenario too, daily average cases will be between 1.2 and 1.5 lakh in the country. The number of serious infections requiring oxygen or ICU will also be lower," he said.

Fri, 27 Aug-21; Telangana Today - Hyderabad: Size : 110 sq.cm.; Circulation:149245; Page : 6

### Telugu name on IIT-H logo

STATE BUREAU  
Gannur

Trilingua Logo of IIT Hyderabad. Being local, think global.

Director of IIT-H Prof BS Murthy is also a Telugu man. The premier institute will use the new logo for all official documents.

The design philosophy of IIT-H which was founded in 2008 has the original logo based on two keywords "innovations and innovation." It is depicted in the logo using two Ts with a common dot above them. These two letters emanate outwards in both directions signifying expansion and growth of knowledge. This reflects the

core values of the institute where it fosters and facilitates in expanding one's intellectual ability, creativity, research and scientific discoveries.

The identity is a symbolic representation of a person reading a book. This indicates imparting knowledge through quality education. The logo has also been envisaged with another deeper and philosophical meaning. The circle in the logo depicts the sun, the primary source of energy. The portrayal of the sun symbolizes glowing light, force, creation, growth and strength.

Since a good number of IIT-H students are from the Telugu speaking States, they also shared the new logo on their timelines. The management said "New

# IITH in News



## ఇక సంచార టీకా... చకచకా!

**వ్యాక్సీన్ అన్ పీల్డ్ తో కలిపి సర్వాదు సర్వాహల**

తెలంగాణ సామాజిక కార్యకర్తల టీకా అందించే పథకం ప్రారంభం చేసిన సందర్భంగా సులభంగా ప్రజలకు అందుబాటులో ఉండేలా ప్రత్యేకంగా రూపొందించిన 'వ్యాక్సీన్ అన్ పీల్డ్' సేవను ప్రారంభించినట్లు తెలుస్తోంది. ఇందులో వ్యాక్సీన్ అన్ పీల్డ్ సేవను ప్రజలకు అందుబాటులో ఉంచేలా ప్రత్యేకంగా రూపొందించినట్లు తెలుస్తోంది. ఇందులో వ్యాక్సీన్ అన్ పీల్డ్ సేవను ప్రజలకు అందుబాటులో ఉంచేలా ప్రత్యేకంగా రూపొందించినట్లు తెలుస్తోంది.



టీకా వాడుకలో 'వ్యాక్సీన్ అన్ పీల్డ్' కృతకంపాటుకు జిగ్గెడ్ పవర్ (ఎల్ఎస్ టెక్నాలజీ) రోలంబు చేస్తోంది. బృందం సభ్యులు.

Date : 25/09/2021 EditionName : TELANGANA  
PageNo : 11

## THE TIMES OF INDIA

Copyright © 2014 Bennett Coleman & Co. Ltd. All rights reserved  
Thu, 30 Sep-21; Times Of India - Hyderabad; Size : 187 sq.cm.;  
Circulation:267065; Page : 2

### IIT-H research team develops hydrogel to regenerate cornea

Times News Network

**Hyderabad:** Scarring due to corneal injury can now be prevented thanks to a novel technology developed by researchers at the Indian Institute of Technology Hyderabad (IIT-H). Currently, no treatment is available other than partial donor corneal graft or transplantation for corneal scarring.

A corneal scar is either opacity or irregularity in the cornea that could limit the cornea's ability to accurately focus light. Researchers from the biomedical department at IIT-H collaborated with LV Prasad Eye Institute and Center for Cellular and Molecular Biology to come up with a technique, which is less invasive and can replace complex surgical procedures in ophthalmology.

Using discarded cornea from slaughterhouses and disqualified cornea for transplantation from eye banks, the team of researchers have developed a tissue-engineered hydrogel that when injected can regenerate the cornea without scarring.

"We have tested the corneal hydrogel for two complications associated with cornea — corneal scarring and kerato-

#### A RELIEF FROM COMPLEX SURGERY

• The technology can reduce some of the complex surgical procedures in ophthalmology

• It was developed using discarded cornea from slaughterhouses and disqualified cornea for transplantation from eye banks

• The processing method is simple and using only eco-friendly and harmless chemicals

• Preclinical studies indicate that the corneal scar for which cadaveric corneal grafting is the only available option currently, can be cured using this hydrogel

• Its potential to treat chronic corneal disorders was also explored with successful outcomes



conjunctivitis — and, in both cases, we found that this can be successfully used as a new treatment strategy to avoid complicated surgeries," Shilpa Chatterjee, PhD scholar, department of biomedical engineering, IIT-H, said, adding that the institute was also planning for human pilot studies for some of its applications soon.

Experts believe that this technology would have a huge impact in countries where there was a scarcity of eye bank and donor tissue. "The southern part of India is much more developed than north for eye care. Still, states like Uttar Pradesh and Bihar have the least access-

## THE TIMES OF INDIA

Copyright © 2014 Bennett Coleman & Co. Ltd. All rights reserved  
Sun, 19 Sep-21; Times Of India - Hyderabad; Size : 87 sq.cm.;  
Circulation:267065; Page : 5

### 13 Japanese cos to attend fair in city

Times News Network

**Hyderabad:** More than 150 alumni of the Indian Institute of Technology, Hyderabad (IIT-H) are in Japan following the joint industry-academia-government collaboration with the institute. To enhance it further, 13 Japanese companies are set to attend a two-day online "Japan Day 2021" celebration, a job fair being organised by IIT-H on September 24-25.

"The strong collaboration of IIT-H with Japan has made this country one of the most preferred destination for our students to study or work abroad. Japan Day, which is being organised regularly for the last two years at IIT-H, is a unique and important event

that greatly helps our students to develop an understanding and confidence about the job, work culture, life and career path in Japan," said Prof. BS Murty, director, IIT-H.

This year, in response to last year's event's survey, which showed that more than half of the participating companies are interested in future collaborative research with IIT-H, an industry-academia-government session is planned for day 1. Last year, for the first ever online "Japan Day", the institute had 20 Japanese companies as participants. More than half were startups aiming to recruit Indian top talents to develop their technologies and products to compete in the global market.

Telangana Today

## Building constructed with bio-bricks

STATE BUREAU Sangareddy

With the objective of meeting the twin goals of addressing stubble burning issue and arrest the exploitation of natural resources in making bricks, research scholars at the Indian Institute of Technology, Hyderabad (IIT-H) developed bio-bricks with stubble.

The scholars constructed a building with bio-bricks on the premises of the IIT-H Campus, a first of its kind in the country. The structure will be inaugurated on Thursday by the Director of IIT-H Prof. BS Murthy. The bricks were developed by Priyabrata Raatray, a Ph.D. scholar in the Department of Design. He was guided by Prof. Deepak John Matthew, head of the Department of Design at IIT-H.

While on the one hand natural resources and fertile soil were being used to make bricks to meet the needs of the construction industry in the country, on



The structure built with bio-bricks at IIT-Hyderabad.

the other hand, stubble burning had become a major issue in the country. To address these twin issues, Priyabrata Raatray used agriculture waste such as paddy straw, wheatgrass, cotton plants, and sugarcane waste after the crushing to make the bricks. Traditional brick making also causes a lot of pollution, he said. According to estimates, the agriculture sector produces 500 million tonnes of waste every year in India.

## EVs being used on campus



Electric vehicles being used on IIT-Hyderabad campus in Sangareddy on Wednesday.

**SANGAREDDY:** To reduce pollution on campus, authorities of the Indian Institute of Technology-Hyderabad (IIT-H) have begun using three 14-seater electric vehicles for transport within the campus. The students, staff, faculty and visitors must use these three vehicles to travel anywhere on the campus, spread over 573 acres in Sangareddy. The Institute used to operate normal vehicles from the entrance to the academic block, hostels, and

staff quarters. The use of personal vehicles by students was banned a few years ago when rash and negligent driving resulted in a couple of accidents. Since then, all the students were travelling in fuel run vehicles such as buses, cars and autos to travel on the campus. The fuel run vehicles were hired through a contractor. The three new vehicles were also hired through a contractor to be operated on the campus.

## मिलाप

Copyright 2014 Daily Hindi Milap. All rights reserved.

Wed, 22 Sep-21; Daily Milap - Hyderabad; Size : 35 sq.cm.;  
Circulation:44300; Page : 4

## आईआईटी हैदराबाद का हिन्दी सप्ताह समारोह संपन्न

हैदराबाद, 21 सितंबर (विशेष ब्यूरो)

आर्य समाज के अध्यक्ष श्री. ए.एस. मुर्ती ने आईआईटी हैदराबाद में हिन्दी सप्ताह समारोह का शुभारंभ किया।

हिन्दी सप्ताह का शुभारंभ समारोह के विवेकानंद एवं राजगुरु कार्यक्रमों के अंतर्गत श्री. बी.एस. मुर्ती ने किया।

समारोह में विवेकानंद एवं राजगुरु कार्यक्रमों के अंतर्गत श्री. ए.एस. मुर्ती ने हिन्दी सप्ताह समारोह का शुभारंभ किया।

समारोह के अंतर्गत श्री. ए.एस. मुर्ती ने हिन्दी सप्ताह समारोह का शुभारंभ किया।



आईआईटी हैदराबाद में हिन्दी दिवस समारोह के दौरान प्रतिभासिद्धि को प्रमाण-पत्र विनिर्दिष्ट करके संस्थान के निदेशक प्रो. बी.एस. मुर्ती।

समारोह के विवेकानंद एवं राजगुरु कार्यक्रमों के अंतर्गत श्री. ए.एस. मुर्ती ने हिन्दी सप्ताह समारोह का शुभारंभ किया।

समारोह के अंतर्गत श्री. ए.एस. मुर्ती ने हिन्दी सप्ताह समारोह का शुभारंभ किया।

समारोह के अंतर्गत श्री. ए.एस. मुर्ती ने हिन्दी सप्ताह समारोह का शुभारंभ किया।

Fri, 10 Sep-21; Telangana Today - Hyderabad; Size : 379 sq.cm.;  
Circulation:149245; Page : 2

## IIT Hyderabad 16th best in NIRF ranking

UoH bags 9th position and OU 32nd in the university category

CITY BUREAU Hyderabad

The Indian Institute of Technology (IIT) Hyderabad has improved its National Institutional Ranking Framework (NIRF) 2021 overall ranking by one position. The IIT Hyderabad secured 16th rank among the educational institutions in the country while it was in 17th position in the 2020 rankings.

The IIT Madras has topped in the overall rankings which was released by Union Education Minister Dharmendra Pradhan on Thursday. The Indian Institute of Science and IIT Bombay bagged second and third positions.



The Indian Institute of Technology Hyderabad has improved its NIRF 2021 overall ranking by one position.



## పూల వనం.. చదువుల ప్రాంగణం

చదువుల ప్రాంగణమైన ఐఐఐటీ హైదరాబాద్ విద్యార్థులకు పూలతో స్వాగతం పలుకుతోంది. రోడ్డు మధ్యలో, ఇరువైపులా రంగురంగుల పూల మొక్కలు ఆహ్లాదాన్ని పంచుకున్నాయి. కూడలిలో గార్డెన్ లా ఉన్న రకరకాల పూల మొక్కలు మంత్రముగ్ధుల్ని చేస్తున్నాయి.

- సాక్షి స్టాఫ్ ఫోటో గ్రాఫర్, సంగారెడ్డి

# Campus Corner

## Collaborations



IIT Hyderabad and PharmCADD signed a pact for the co-development of new drugs.

PharmCADD, a leading in-silico drug design company, and IIT Hyderabad also agreed to promote the alliance by jointly participating in global R&D projects.

Read more at: <https://tinyurl.com/9xr4z4pb>

IIT Hyderabad & IISc Bangalore, signed an MoU for mutual co-operation in Academic and Research Activities.



IIT Hyderabad & IAMRAI Forum Hyderabad signed an MoU for Academic and Research Activities in the field of Biomedical Engineering, Device Development, MEMS Technology & topics of mutual benefits.

IIT Hyderabad & RGUKT, Andhra Pradesh signed an MoU to facilitate collaborative research work, establish Academic and Scientific relationships, promote joint research activities, and extend mutual support in Post-Graduate and Doctorate programs.





# Campus Corner

## Collaborations



IIT Hyderabad & Military College of Electronics and Mechanical Engineering MCEME signed an MoU for enhancing academic & intellectual interactions in various fields of Defence, Science & Technology.

IIT Hyderabad Indian Institute of Petroleum and Energy IPE, Visakhapatnam signed an agreement for Academic & Research Collaboration.



IIT Hyderabad, Kepler Aerospace & Aidin Technologies signed an agreement for Collaborative Research, Development, and Implementation of Space and Aerospace Domain Projects.

Individually we are a drop;  
but together we are an  
ocean.

RYUNOSKE SATORO

# Campus Corner

Seminars - Natfoe 2021 jointy organized by IIT Hyderabad & INAE and others

THIS JULY 9, 2021 AT  
NATFOE2021 SYMPOSIUM

Hear Dr Yessy Thomas

(Distinguished Scientist &  
Director General - Aeronautical Systems (AS)  
DRDO, Ministry of Defence, Government of India)

views on

"Advances in Aerospace Materials  
and Manufacturing Technologies"

Date: July 9, 2021, Friday  
Time: 17:15-18:00 hrs  
Join us on Webex:  
<https://iith.webex.com/meet/office>



THIS JULY 10, 2021 AT  
NATFOE2021 SYMPOSIUM

Hear Dr Debashish Bhattacharjee

Vice President (Technology and New Materials Business),  
Tata Steel

views on:

"Evolution of high strength  
automotive steels and their future"

Date: July 10, 2021, Saturday  
Time: 17:45-18:30 hrs  
Join us on Webex:  
<https://iith.webex.com/meet/office>



Sufi Qawwali  
by  
Ahmed Brothers  
Date: July 9, 2021, Friday  
Time: 18:30-19:30 hrs  
Livestreaming on IITH Youtube Channel



Inaugural Program Schedule of  
15th NatFoE Symposium  
on  
July 9, 2021 (Friday), 9:00-9:25

WebEx Meeting Link: <https://iith.webex.com/meet/office>

- 09:00 - 09:05 Welcome Remarks (Prof. B. S. Murty, Director, IIT Hyderabad)
- 09:05 - 09:10 About NatFoE Symposium: Prof. Sivaji Chakravorti, Vice President, INAE
- 09:10 - 09:20 Presidential Remarks (Prof. Indranil Manna, President, INAE)
- 09:20 - 09:22 Releasing Symposium Abstract Booklet
- 09:22 - 09:25 Vote of Thanks (Dr. Chandra Shekhar Sharma, Coordinator, NatFoE2021)

IIT Hyderabad, along with IIT Gandhinagar and IISc Bangalore, is organising an "International Workshop on

**Quantum Information in QFT and AdS/CFT-II**  
18th-20th August 2021

About the Program:  
The workshop brings together some of the leading global experts to discuss recent developments on quantum information and computation applied to field theory and holography. This workshop is organized jointly by the members of Indian Institute of Technology, Gandhinagar (IITG), Indian Institute of Technology, Hyderabad (IITH) and Indian Institute of Science (IISc) Bangalore working on quantum gravity on 18th-20th August 2021.

The workshop will be on the online platform ZOOM. The ZOOM link will be shared with the registered participants by Email.

Speakers:

- Jonk-L.F. Barberis, IFT, Madrid
- Aranya Bhattacharyya, IISc, Bangalore
- Paolo Corinti, University of Warwick
- Shrey Chakraborty, Ben-Gurion University
- Bartek Czech, USC - Longue University
- Hagar Gharibyan, Caltech
- Michael Heller, MPI, Aachen
- Siddharth Mittal, Caltech
- Chiranjeev Prakash, IITR, Mumbai
- Sourav Raju, IISc, Bangalore
- Gabriel Sáenz, CERN
- Edgar Shaghoulian, IAS, Princeton
- James Sully, University of British Columbia
- Tadashi Takahashi, IITD, Roorkee
- Ying Zhao, USC, Princeton

Oral Presentations:  
Ajay K. Patra (IITG), Kulkarni, Ganesh Kumar (IIT Hyderabad), Pratik Nayak (IISc Bangalore)

Organizers:  
Aranya Bhattacharyya, IIT Gandhinagar (IITG), Shubho Roy IIT Hyderabad (IITH), Aninda Sinha, Indian Institute of Science (IISc)

Register Here  
Workshop Schedule  
Programme Details

ATAL FDP Workshop on  
Energy Conversion and Storage Devices (ECS-21)  
July 1-5, 2021



Organized by  
Department of Physics, IITH



Inaugural Session on July 1, 2021

- Dr. Sai Santosh Raavi  
Workshop Coordinator
- Prof. V. Kanchana  
HoD, Physics, IITH  
Opening Remarks
- Prof. Saptarshi Majumdar  
Dean Academic, IITH  
Inaugural Remarks
- Prof. B. Umashankar  
Chair, CCE, IITH  
Concluding Remarks
- Prof. V. Pillai  
Dean, IISER Tirupathy  
Inaugural Lecture



# Campus Corner

## Seminars & Talks

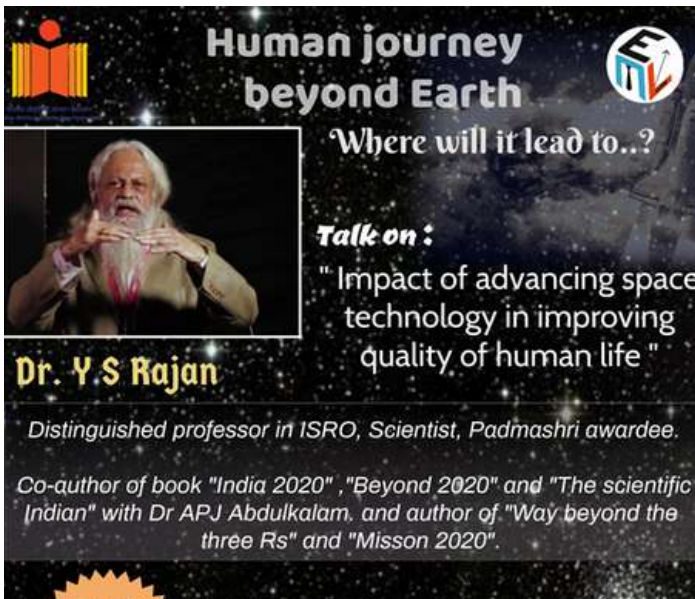

**Human journey beyond Earth**  
Where will it lead to..?

**Talk on :**  
" Impact of advancing space technology in improving quality of human life "

**Dr. Y S Rajan**  
Distinguished professor in ISRO, Scientist, Padmashri awardee.  
Co-author of book "India 2020", "Beyond 2020" and "The scientific Indian" with Dr APJ AbdulKalam. and author of "Way beyond the three Rs" and "Misson 2020".



ITIC Incubator, Entrepreneurship & Management Dept. and Institute Innovation Council invite you to...

**4:00pm**  
**24<sup>th</sup> August**  
**(Tuesday)**

*Orientation Session on Entrepreneurship & Incubation Opportunities and Support Systems at IIT Hyderabad*

IIT Hyderabad along with Brookhaven National Lab, WashingtonUniversity in St. Louis & IMSc, Chennai is going to organize the online conference "Anomalies 2021" during November 10-12, 2021.



**ANOMALIES 2021**  
International Conference (online)  
IIT Hyderabad, Kandi, Telengana - 502285

**Contents**  
Gravitational wave like signature and finite temperature field theory  
Hadronic & leptonic colliders  
Flavour Physics & muon g-2  
Dark matter & Neutrino Physics

**National and International Organizing Committee**  
Dr. Prayobh Bandyopadhyay  
Indian Institute of Technology, Hyderabad, India  
Prof. Rahul Sinha  
Institute of Mathematical Sciences, Chennai, India  
Dr. Bhupal Dev  
Washington University, St. Louis, US  
Prof. Anupam Sori  
Brookhaven National Lab, Upton, US

**Local Organizers**  
Dr. Prayobh Bandyopadhyay  
Prof. Anupam Sori  
Dr. Anandita Saha  
Dr. Bhargavendra Subrah Hundi  
Dr. Susrabh Sanjaya  
Dr. Anubhav Karan

**10th - 12th Nov, 2021**  
For registration, abstract submission, and other queries please visit the following website:  
<https://www.iith.ac.in/~anomalies10anomalies2021.html>  
Deadline for registration & abstract submission: 30th Sep, 2021



**Prof. Padmanabhan Balaram**  
E-talk on -  
**Indian Higher Education: The New Education Policy Viewed Through the Lens of Recent History**

**Awards and Decorations**  
• He is a recipient of the third highest Indian civilian Honour of Padma Bhushan as well as the TWAS Prize.

**30 SEP THURSDAY 5:00 PM**

**follow us** @emliith

Gokul lab @IITHyderabad in association with the University of Exeter, UK has organized an international SPARC Workshop this month on Multi-objective Optimization Under Uncertainty



**SPARC Virtual Workshop on Multi-Objective Optimization under Uncertainty (with a focus on Wind-Farm Micrositing)**  
10-12 September 2021

**KEYNOTE SPEAKERS**  
Prof. Kalyanmoy Deb  
Prof. Anandita Saha  
Prof. Anupam Sori  
Prof. Bhargavendra Subrah Hundi  
Prof. Susrabh Sanjaya  
Prof. Anubhav Karan

**UNCERTAINTY HANDLING IN MULTI-OBJECTIVE AND MULTI-LEVEL OPTIMIZATION**  
**Kalyanmoy Deb**  
University Distinguished Professor  
Koenig Endowed Chair Professor  
Comput. Optimization and Innovation (COIN) Lab.  
Michigan State University  
East Lansing, MI 48864, USA  
Email: kdeb@egr.msu.edu  
Web: [www.coin-lab.org](http://www.coin-lab.org), [www.egr.msu.edu/~kdeb](http://www.egr.msu.edu/~kdeb)

# Campus Corner

## Highlights



IIT Hyderabad now has a new PINCODE, 502284. Sub post office inaugurated at IIT Hyderabad Campus by India Post this July.

### Highlights:

- A fully functional postal service window by the India Post.
- It will cater to all basic postal, banking & insurance requirements of the residents.

IIT Hyderabad @GreenCampus had Plantation Drive on the first Saturday of July 2021. This drive, IITH fraternity planted Delonix regia and Butea monosperma.



Kiriith - Issue - 7, June 2021 #Nanotech @IITHyderabad, a quarterly magazine of IITH, was released to mark the National Broadcasting Day, July 23.

View the KiriIITH flipbook at:

<https://online.fliphtml5.com/vrhd1/pdvk/>

Download from:

[https://pcr.iith.ac.in/KiriIITH\\_Issue-7\\_July\\_2021\\_Nanotech@IITH.pdf](https://pcr.iith.ac.in/KiriIITH_Issue-7_July_2021_Nanotech@IITH.pdf)

IIT Hyderabad has set up a comprehensive waste management system on Campus. A Resource Recovery Park (RRP) and the bio-digester are steps towards sustainable waste management, said Prof B S Murty, Director, IIT Hyderabad.

Read more at: <https://tinyurl.com/r4s6mfr4>



# Campus Corner

## Highlights

**Dr Subrahmanyam Kalyanasundaram**  
Head & Associate Professor  
Department of Computer Science & Engineering

will be teaching a course on **Computational Complexity** via nptelindia in the upcoming semester

Deadline to apply Aug 9, 2021



IIT Hyderabad is glad to share that Dr Subrahmanyam Kalyanasundaram, will be teaching a course on Computational Complexity via nptelindia in the upcoming semester.

DAV Campus School Inauguration at IIT Hyderabad by our esteemed Chairman, BoG, Dr @BVRMohanReddy, and beloved Director Prof B S Murty in the presence of the delighted IITH fraternity and DAV team.



The SUTRA model by the team led by

**Prof Vidyasagar M**  
Distinguished Professor, IIT Hyderabad

is referenced on the first page of the RBI's "State of the Economy" Report for July, 2021

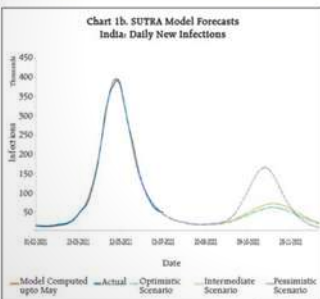

IIT Hyderabad is glad to share that The SUTRA model by the team led by Prof Vidyasagar M, is referenced on the first page of the RBI's "State of the Economy" Report for July 2021.

# Campus Corner

## Highlights



IIT Hyderabad established its first astronomical observatory with a large telescope for public outreach, this August 15 and also celebrated 75th Independence Day in a new normal.

1,323 degrees conferred during 9th & 10th Joint Convocation at IIT Hyderabad. 1,303 students graduated from the 2020 & 2021 batch in the august presence of Hon'ble Minister of Education Shri Dharmendra Pradhan with 8 Gold Medals & 47 Silver Medals.

Read more at: <https://tinyurl.com/3ssdu39u>

View the event at: [https://youtu.be/BhxCss\\_yF0o](https://youtu.be/BhxCss_yF0o)

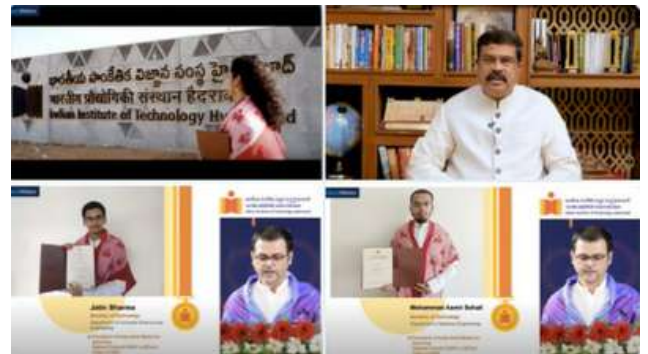

It is a day to bookmark in the journey of IIT Hyderabad when the state-of-the-art infrastructure and facilities were inaugurated by Hon'ble Minister of Education Shri Dharmendra Pradhan. With these facilities of global standard, it will establish IITH among A-league facilities in the field of Materials Science & Metallurgical Engineering, AI & Cyber Security.

Read more at: <https://tinyurl.com/vraubdv>

IIT Hyderabad organized Fit India Freedom Run 2.0 on the august occasion of Celebrations of India's 75 years of Independence- Azadi Ka Amrut Mahotsav with the theme, Fitness ki Dose - Adha Gantha Roz



# Campus Corner

## Highlights



IIT Hyderabad released its New Trilingual Logo of on social media.

Being Local, Think Global!!!

IIT Hyderabad has arranged an Exhibition match of Hockey to observe the National Sports Day. The monumental victory in Tokyo Olympics 2020 makes it all the more important for us to celebrate National Sports Day with vigor & enthuse by remembering Major Dhyan Chand Singh.



E-Vehicles on the campus of IIT Hyderabad. In order to utilize the newer technologies and to reduce campus pollution, IIT Hyderabad started running E-Vehicles inside the Campus effective from September 1, 2021.

IIT Hyderabad, NXP & FabCI, IITH are happy to welcome the 8 Startups into the 2-year Incubation & Acceleration Program. Response to the program has been very encouraging and from 50+ applications received, 35 were shortlisted, out of which only 11 startups were able to impress our jury panel. With these 11 selected startups, we carried out a 3-day Virtual Boot Camp. At the Pitching Day, all the 11 startups competed to the best of their ability to impress the Judges panel, comprised of industry & NXP experts.

Congratulations to the Finalists!!!



# Campus Corner

## Highlights

**SWACCH BHARAT PAKHWARA**

SEPTEMBER 1-13, 2021

ON THE OCCASION OF SWACCH BHARAT PAKHWARA

ON THE OCCASION OF SWACCH BHARAT PAKHWARA

Exciting prizes await winners apart from getting featured on our pages.

**HEALTHY SURROUNDINGS = HEALTHY LIFE**

ON THE OCCASION OF SWACCH BHARAT PAKHWARA

If you need to do a task a pic of your room/home/office, take a creative listing if up and either post your entries on social media pages tagging us or submit your entries via a mail to [ehsclub@campus.iith.ac.in](mailto:ehsclub@campus.iith.ac.in)

**ESSAY WRITING COMPETITION**

ON THE OCCASION OF SWACCH BHARAT PAKHWARA

You may choose to write on any topic related to cleanliness in Hindi or English. Entries should be limited to 200 words and above as well as handwritten entries are accepted. Submit your entries via email to [ehsclub@campus.iith.ac.in](mailto:ehsclub@campus.iith.ac.in)

**SLOGAN MAKING COMPETITION**

ON THE OCCASION OF SWACCH BHARAT PAKHWARA

Entries in Hindi or English will be accepted. Submit your entries via a mail to [ehsclub@campus.iith.ac.in](mailto:ehsclub@campus.iith.ac.in)

EBSB club @IIT Hyderabad celebrated Swachh Bharat Pakhwada from Sep 1-13, 2021 with exciting Essay Writing, Slogan Making & Healthy Surroundings = Healthy Life.

IIT Hyderabad united together to fight the Pandemic, conducts a series of on-campus Vaccination programs for Faculty, Staff, Students, Employees & their Families. Thanks to our Staff, Faculty & Students' Volunteers who made it possible!

Special Thanks to Kandi PHC Doctor-Dr Prashanth, Dist Immunisation officer-Dr Shashanka, DMHO-Dr Gayatri Devi & the Nursing staff for their support. Kudos to IIT Hyderabad Medical Team: Dr Anil K, Dr Baishakhi, Dr Raja, Dr Anil V, Dr Sushma, Dr Rohith, Dr Robinson & Clinic Staff.



 Institute Innovation Council  
 INSTITUTE'S INNOVATION COUNCIL  
 Indian Institute of Technology Hyderabad  

(3<sup>rd</sup> Quarterly Meeting, Q4, 2020-2021, August 26, 2021)  
(16.30-17.30)

4:00pm - 26<sup>th</sup> August (Tuesday)

Celebration Session on Entrepreneurship & Incubation Opportunities and Support Systems at IIT Hyderabad

IIT Hyderabad has successfully conducted its 3rd Meeting among the new council as per IIC3.0 by MoE & the last meeting of the Academic Year 2020-21 to discuss various initiatives for the promotion of Innovation & Entrepreneurship on Campus.

**NIRF2021:**  
 #16 Overall Ranking  
 #15 Research Ranking  
 #8 Engineering Ranking

What made IIT Hyderabad remains strong....

Read more at: <https://tinyurl.com/4h7aeyxb>

**#16 Overall Ranking**  
**#15 Research Ranking**  
**#8 Engineering Ranking**

What made us remain strong....

  
 National Institutional Ranking Framework  
 Ministry of Higher Education, Government of India



Inventing and Innovating in Technology for Humanity (IITH)

Indian Institute of Technology Hyderabad



# Campus Corner

## Highlights



IIT Hyderabad celebrated the Ganesh Festival for four with a lot of joy and festive bliss on the campus by fellow residents.

To observe World Suicide Prevention Day '21, IIT Hyderabad organized a 'Save a Plant, Save a Life' Plantation drive. Plantation has a lot of rewarding benefits over the human mind. Such as:

1. Increase in the release of happiness-causing neurotransmitters.
2. Enhanced mindfulness, self-esteem, & optimism while being engaged in the steps like watering the plants, digging the soil, and perceiving the fragrance of flowers and petrichor.
3. Getting a feeling of belongingness while taking care of the plant and its nearby place and many more.



13 Japanese companies attended the two-day online "JAPAN DAY 2021" at IIT Hyderabad on Sep 24-25, jointly organized by JICA & JETRO. Joint Industry-Academia-Government session held for the 1st time for nurturing future collaboration between India and Japan.

Read more at: <https://tinyurl.com/m3eewx24>

हिंदी सप्ताह समापन एवं पुरस्कार वितरण समारोह, 2021

कार्यक्रम का प्रसारण देखें:  
<https://youtu.be/BzwxOCqmWnw>

हिंदी सप्ताह समापन एवं पुरस्कार वितरण समारोह, 2021 @IITHyderabad



# Campus Corner

## Highlights

**3X3 Basketball Tournament @IITHyderabad**



Pic Courtesy: Ms Ruchi Yadav, Sports Officer

3X3 Basketball Tournament organized by the sports department @IIT Hyderabad as a part of "Fitness Ki Dose, Adha Ganta Roz" Drive.

The theme for this year's World Physiotherapy Day is Rehabilitation and Long COVID. On this day, Physiotherapists, and the Student Council have launched the WalkClub to build a healthier community at IIT Hyderabad.

**Launching of Walk Club @IITHyderabad**



Honorable Minister of Education Shri Dharmendra Pardhan Ji met Dr BVR Mohan Reddy, Founder & Executive Chairperson @Cyient, and BoG Chairperson @IIT Hyderabad & @IIT Roorkee. They had interesting exchanges on IITs as a springboard in making this decade 'India's Techade', equipping youth with future skills & ways to make learning smarter.

WalkClub @IIT Hyderabad (Physiotherapist and Student council) has organized a mini-marathon to celebrate World Heart Day and promote the importance of physical activity at the community level.

**Mini-Marathon by Walk Club @IITHyderabad**



# Campus Corner

## Campus View



#IITHCampusCorner  
**Subabul**  
(*Leucaena leucocephala*),  
A Miracle Tree  
#IITHHyderabad

Pic Courtesy: Ms. Sujata Somaraju

#IITHCampusCorner  
The Temple of Education is surrounded by the green carpet

Pic Courtesy: ShivaPrasad, Sakshi News



#IITHYaadein

The iconic hostel building of IITH in making...

Monsoon @IIT Hyderabad



Pic Courtesy: Dr Ambika S,  
Assistant Professor, Department of Civil Engineering



#IITHYaadein

The introduction of Elan in IITHians Diary...

Illuminating IIT Hyderabad



Pic Courtesy: Rekhala Vikram, Junior Technician,  
Department of Mechanical and Aerospace Engineering



Sparkling Skyline @IIT Hyderabad

Pic Courtesy: Ms Sujata Somaraju

Mongoose pair relishing in the green belt of IITH



Pic Courtesy: Kisshore Kampara, Research Scientist, CARBON Lab, IITH

# Campus Corner

## Campus View

Keep a Green tree in your heart and perhaps a singing bird will come...



Pic Courtesy: Ganapathi Patil, Research Scholar, Department of Civil Engineering



Brahma Kamalam (Saussurea obvallata)  
@ IITH

Pic Courtesy: Ms Sujata Somaraju

### The Scenic Roadways @IITHyderabad



Pic Courtesy: Mr Dhananjay Sahoo, Central workshop

### Exquisite Evenings @IITHyderabad



Pic Courtesy: Ms Vedavani A, Physiotherapist

### Tricolor Walkways @IITHyderabad (A view of Staff Condos)



Pic Courtesy: Dr Shiva Ji, Department of Design

STAY TUNED FOR THE NEXT ISSUE  
TO SEE MANY MORE COLORS OF

#IITHCAMPUSCORNER

# Moment of Pride

## Dr Abhinav Kumar

(Department of Electrical Engineering)

for recognition as

### Best Supervisor

at IEEE ComSoc GraTE-7, 2021



## Ms Yoghitha Ramamoorthi

(PhD Scholar)

for recognition as

### Best Thesis Award

at IEEE ComSoc GraTE-7, 2021



## Dr Vineeth and his team of CSE students

for receiving

### Best Paper Awards at CVPR 2021 Workshops



Dr Vineeth N Balasubramanian  
Head (AI) & Associate Professor  
Dept of CSE & CC



Abbavaram Gowtham Reddy,  
PhD Scholar, CSE



Benin Godfrey  
Project staff, CSE



Puneet Mangla  
BTech, CSE



Vedant Singh  
BTech, CSE



Shreyas Havaldar  
BTech, CSE

## Awardees of the *Reliance Foundation Scholarship*



Prashanth Vaidya R



Sumitra Malagi R



Vaasudev Narayanan

(MTech, Department of CSE)



Adarsh Srivastava



Arkadipta De



Priya Bhatia



Tuhin Dutta

(MTech, Department of AI)

## Mr Manoranjan Dutta

Research Scholar, Department of Physics

### for "Best Oral Presentation" award

at National conference on the  
Emerging Trends in Physics



## Prof Prabusankar Ganesan

Department of Chemistry

for his paper being featured

### On The Cover in EJIC Wiley-VCH

and made into

### My Favourite EurJIC Top Authors

EurJIC  
European Journal of Inorganic Chemistry

#MyFavouriteEurJIC

Chemistry  
Europe  
European Chemical  
Societies Publishing

Chalcogen Bonding Induced  
Tetraselenides from Twisted Diselenides

Mouali Vaddamanu, Ganesan Prabusankar

Indian Institute of Technology Hyderabad

eurjic.org

## Prof Kishalay Mitra

Department of Chemical Engineering

for being inducted into the

### Editorial Board

of the

International Journal of Materials  
and Manufacturing Processes



# Moment of Pride

## **Dr Anand Mohan**

Department of Chemical Engineering

for being selected as an

### **Editorial Board Member**

of the  
Journal Systems Biology and  
Physiology Reports



## **Mr Syed Sadique Ali**

Section Officer (Finance & Accounts)

for being selected as

"Employee of the month" for  
the Month of July 2021



#MomentofPride

## **Mr. Vineet Gairola**

Ph.D. Scholar  
Department of Liberal Arts

for receiving the  
Student Research Award  
from the  
American Psychology Association



## **Dr Shahid Mohammad**

Assistant Professor  
Department of Design

for his poster being selected for one of the  
Best Typography Poster awards  
at Typography Day 2021



## **Dr Vandana Sharma**

Associate Professor  
Department of Physics

for being selected as  
Review Editor for *Frontiers in Physics*:  
Atomic and Molecular Physics



## **Mr A Srinivas Rao**

Executive Assistant, Research & Development Section

for being selected as

"Employee of the month" for  
the Month of August 2021



# Moment of Pride

## **Ms Purva Kherkar**

*Lady Physical Training Instructor, Department of Sports*

for being awarded

The National Sports  
Excellency Award 2021



## **Dr Jyotsnendu Giri**

*Associate Professor,  
Department of Biomedical Engineering*

for being selected for the

Abdul Kalam Technology  
Innovation National Fellowship  
by INAE



## **Dr Aravind Kumar Rengan**

*Assistant Professor,  
Department of Biomedical Engineering*

for being selected for the

BRICS Young Scientist Forum 2021



## **Dr Aardra Surendran**

*Assistant Professor,  
Department of Liberal Arts*

for being selected as a

member of the working group on  
'Knowledge Economy, Employment and Skills'  
as a part of the formulation of the  
14th five year plan of the Government of Kerala.



## **Prof Saket Asthana**

*Professor,  
Department of Physics*

for being admitted as

Fellow of the Royal Society  
of Chemistry



## **Ms Mitalee Agrawal**

*Public Relations Officer, IIT Hyderabad*

for being awarded jury special

Chanakya Award 2021 as the  
Social Media Person of the Year  
by Public Relations Council  
of India (PRCI)



# Moment of Pride

## Dr Sarjerao B Doltade

PhD in Chemical Engineering  
Co-founder at GermSafe Technology LLP  
NICE Fellow, i-TIC incubator at IIT Hyderabad

for being selected for the

BRICS Top 5 Innovator (under 30 years)



## Mr S VenkataKeerthy

PhD Scholar, Department of Computer Science & Engg. &

## Ms Piyushi Manupriya

PhD Scholar, Department of Computer Science & Engg.

For receiving

the prestigious Google PhD Fellowship for the year 2021



Mr S VenkataKeerthy



Ms Piyushi Manupriya

## Ms Mitalee Agrawal

Public Relations Officer, IIT Hyderabad

for being awarded jury special

Ameya of the Year  
for being an  
Influential Women Motivator  
by Public Relations Council  
of India (PRCI)



## Mr Thimothi,

MSA (Finance & Accounts)

for being selected as

"Employee of the month" for  
the Month of September 2021



Surround yourself with  
positive energy

Pic Courtesy: Ganapathi M. Patil



భారతీయ సాంకేతిక విజ్ఞాన సంస్థ హైదరాబాద్  
भारतीय प्रौद्योगिकी संस्थान हैदराबाद  
Indian Institute of Technology Hyderabad

**Created & Published By:**

**Public Relations Office  
IIT Hyderabad**

Room 215, Academic A Block  
Indian Institute of Technology Hyderabad,  
Kandi, Sangareddy - 502284, Telangana, India  
Contact: +91 40-2301 6099, +91 83310 36099  
E-Mail: pro [at] iith [dot] ac [dot] in