

# किराIITH



the crowning glory \_\_\_\_\_

A quarterly e-newsletter of IITH | Volume 4 | Issue 2 | Apr - Jun 2022

#Smartmobility@IITH

భారతీయ సాంకేతిక విజ్ఞాన సంస్థ హైదరాబాద్  
भारतीय प्रौद्योगिकी संस्थान हैदराबाद  
Indian Institute of Technology Hyderabad



Kargil Vijay Diwas is commemorated every 26 July, to observe India's victory in the Kargil War for ousting Pakistani Forces on the mountain tops of Northern Kargil District in Ladakh in 1999.

Kargil Vijay Diwas  
26 July

# Inside the Issue

Editorial Epistle | 3

Director's Desk | 4

Dean's Diary | 5

- Internationalization of IITH | KID: 20220201 | 5

Theme Diary | 6 - 7

- Smart Mobility @IIT Hyderabad | KID: 20220202 | 6 - 7

Research Diary | 8 - 20

- 5G and Edge Computing assisted Mission Critical ITS Applications | KID: 20220203 | 8 - 9
- Heterogeneity in the Driver Behavior: An Exploratory Study Using Real-Time Driving Data | KID: 20220204 | 9 - 10
- Catalyzing Autonomous Navigation Design Thinking across India | KID: 20220205 | 10 - 12
- Open-air Off-street Vehicle Parking Management System for IITH using Deep Neural Network | KID: 20220206 | 13 - 15
- Distributed and Federated Learning | KID: 20220207 | 16
- Design and Fabrication of Autonomous Passenger Drone | KID: 20220208 | 17
- World of PAVs- Practice-based research on Personal Aerial Vehicles | KID: 20220209 | 18 - 20

Students' Diary | 21 - 22

- My Smart Mobility Journey | KID: 20220210 | 21 - 22
- A great experience that drastically enhanced my life | KID: 20220211 | 22 - 23

Alumni's Diary | 24 - 25

- Design and Development of Autonomous UAV Configuration for Detection and Tracking of Beyond Visual Range Objects | KID: 20220212 | 24 - 25

Incubatee's Diary | 26 - 28

- Activities by iTIC Incubator @ IITH | KID: 20220213 | 26 - 28

IITH in the News | 29 - 32

Campus Corner | 33 - 41

What Next?? | 42

IITH's BoK | 43 - 49

Moments of Pride | 50 - 52

# Editorial Epistle

Dear Readers,

Hope you are doing well!

Inspired by your continuous support, we are pleased to present the 11<sup>th</sup> issue of किराIITH.

Alike every time, this issue of किराIITH is also being dedicated to one of the thrust research areas of IITH. We are glad to release **ten theme-based issues of किराIITH**, namely, COVID-19, AI, Healthcare, IITHinJapan, 5G & Next-Gen Tech, NanoTech, Energy & Integrated Computational Engineering, and Additive Manufacturing.

Following this precedence, किराIITH is back with yet another critical area of research at IITH "**#Smart Mobility**".

We hope this issue of किराIITH - The Crowning Glory, Issue-11, July 2022 #Smart Mobility @IITH will give you a stimulating experience about exceptional research work being carried by the IITH fraternity.

This issue of किराIITH is released on **Kargil Vijay Diwas - July 26** to remember the sacrifice of those brave soldiers who died in the line of duty to protect our country; underlining the importance we give to Invent & Innovate in Technology for Humanity (IITH) to ensure IITH is "**A Dream Destination for Students, Academicians, Researchers & Collaborators**".

किराIITH will be back next quarter with another trending research area. So, stay connected. We wish everyone a safe and healthy stay.

Have a great year ahead...  
Enjoy reading!



**Prof C Krishna Mohan**  
(Dean - Public & Corporate Relations)  
{Editor-in-Chief}



**Prof Deepak John Mathew**  
(Head of the Department - Design)



**Dr Mudrika Khandelwal**  
(Dean - Alumni Relations)



**Ms Ankita Roy**  
(Assistant Professor, Department - Design)



**Ms Mitalee Agrawal**  
(Public Relations Officer)



**Mr Ekshan**  
(Media & PR Head, Student Gymkhana)



**What we fear doing most is usually what we most need to do.**

- Ralph Waldo Emerson

## Inside the Issue

Director's Desk | 3

Dean's Diary | 4

Theme Diary | 5

Research Diary | 8 - 19

Students' Diary | 20 - 22

Alumni's Diary | 23 - 24

Incubatee's Diary | 25- 27

IITH in the News | 28 - 31

Campus Corner | 30 - 40

What Next??? | 41

IITH's BoK | 42 - 48

Moments of Pride | 49 - 51



**Think big.  
Think fast.  
Think ahead.  
Ideas are no  
ones monopoly.**

**- Dhirubhai Ambani**

Dear Friends,

**Hope this monsoon brings up new energy and enlightenment in your life!**

On this elated occasion of unfolding the 11th issue of Newsletter, I am happy to share that, for the **first time, IITH has been Ranked for QS Subject-wise 2022 for Physics & Astronomy**, being at #580-590 in the World. For the **7th consecutive year**, IITH has maintained its position within the **Top 10 ranks among the technical institutes** in the country most coveted **NIRF Ranking 2022**. IITH has also been awarded **four ISO Process Excellence** by HYM International Certification, a third-Party Quality Assurance Certification Body accredited by ASCB(UK).

**TiHAN**, IITH has announced a **Chair** in the field of Autonomous Navigation, and Mr Rajesh Mashruwala, one of the Co-founders of CfHE, IITH, announced the **CfHE Vagbhata Chair Professorship** in Medical Devices and Diagnostics.

**On the research & Innovation front**, IITH is constantly striving to excel in transforming lives for the better through technological innovations. IITH took an early lead in 6G research by showcasing key developments in the use of extreme massive MIMO technology and our researchers developed Innovative Hybrid FRP Strengthening solutions for Civil Infra like existing bridges and buildings.

**In an industry-first effort**, Suzuki Motor Corporation, Japan (SMC), Maruti Suzuki India Limited (MSIL), and IITH have teamed up to research India-specific vehicle usage scenarios based on futuristic V2X (Vehicle-to-Every-thing) communication technology to help reduce traffic incidents and road congestion. IITH presented an exhibition, "World of PAVs" featuring the outcome of the first practice-based PhD and this research aims to explore the forms of Personal Aerial Vehicles (PAVs).

In the **Direction of the Unique Curriculum** and with the vision of making the technology viable to the needs of mankind, the courses we offer help the students to conceptualize the research and inventions and hence IITH announced a self-sponsored **M-Tech program in Ophthalmic Engineering**, in collaboration with the LVPEI, Hyderabad and a **certificate course in Future Wireless Communication** and also IITH unveiled first of its kind, Department of Heritage Science and Technology (HST) with **MTech in HST** on the International Day of Yoga.

IITH has an exceptional Entrepreneurial Ecosystem, to support innovative startups iTIC Incubator at IITH has invested more than **INR 1.5 Crores** in Deep Tech start-ups by selecting **8 deep tech start-ups** from across India to support them via their pre-incubation and incubation support programs.

**Collaborations are vital** in fuelling the strength to accomplish mutual goals. Another advancement in our research & academic collaboration portfolio is **to strengthen the academic & research capabilities within the institute and extend to the partnering institutes** & organizations are MoUs with NIT Sikkim, Nagaland, Agartala, and CSIR NEIST Assam, Commissionerate of Collegiate Education, Govt of Telangana, Kathmandu University, Nepal. A pact is also signed with CMOS - College of Medical Sciences, Nepal, & IIIT Hyderabad to collaborate on the joint program in 'Health Care Technologies'. TiHAN Foundation at IITH and ICAT signed an MoU for collaboration in the area of autonomous navigation. An MoU has been signed between the DST NMICPS TiHAN at IITH and the ICAT for collaboration in research and development in the emerging field of autonomous navigation. IITH, Cyient & WiSig Networks signed a partnership to work together to column produce the "Architected & Designed in India" Narrow Band IoT System on Chip & Manage the supply chain of fabrication, packaging & take it for its commercial use.

The Campus was as vibrant with vivid colors of **celebration of its 14th Foundation Day** with Mr Senapathy "Kris" Gopalakrishnan as the Chief Guest. The ICICI Bank Limited inaugurated its e-lobby at IITH. Hon'ble Minister of Science and Technology, Dr Jitendra Singh inaugurated the DST-IITH, Integrated Clean Energy Material Platform (ICMAP) for Bioenergy and Hydrogen. 5G Testbed inaugurated on campus. Malla Reddy Narayana Hospitals (MRNH), Hyderabad initiated the Cancer Screening program in association with IITH.

The invention of the wheel brought about a revolution in the transportation system, and **now it's time for smart mobility** to make transportation more sustainable. I hope you will all enjoy going through this informative issue.

**Stay safe and Happy...**

# Dean's Diary

## Internationalization of IITH

An international community of students and faculty adds diversity to IITH Campus

**Prof Tarun K Panda**

Dean (International Relations)

KID: 20220201

It is my utmost pleasure to share the information about various activities undertaken by the International Relations (IR) office at IITH. IITH is now one of the paramount institutes globally recognized through its various international accomplishments.

IITH, as a premier 2nd generation institution, has been very forward in its thinking since the day of its inception back in 2008. IITH very quickly recognized the potential of Internationalization and the benefits of connecting to its Alumni all over the world. The Institute introduced the Dean's Office of International and Alumni relations in 2015 to build partnerships all over the world and connect with their alumni to tap the Alumni resources. They would like to compete with other premier institutes or higher education institutions by promoting their strengths internationally.

We have come a long way to envisage that internationalization at IITH plays a very important role and emphasizes more on research collaboration, involving faculty and researchers to contribute to the international community. It is very important to have a vision for internationalization. With this background, we have been very recently separated as the Office of International Relations from the combined Office of International and Alumni Relations. I am the first Dean of the newly formed Office of International Relations and aspire to elevate the Internationalisation of the Institution to the next level.

We are a vision-driven team of four members currently in the Office and are willing to expand further going forward. **We have identify two main verticals to streamline our activities under International relations as "International Admission and International Collaboration."** For "International Admissions," the Indian government (Ministry of Education) has taken measures in recent years to attract international students to take up higher education in India. There are initiatives by GOI like Study in India (EDCIL-SII), ASEAN, and ICCR to enable Internationalisation.

IITH has an exclusive program called FIRST@IITH (Fellowship for International Research Scholars in Technology) to attract International applicants with an attractive fellowship and liberal contingency grants who are interested in pursuing doctoral studies at IITH.

We are hopeful that the FIRST program will be successful in achieving the stated goals in the future. We are also interested in promoting IITH aggressively and looking out for more International students by participating in education fairs in foreign countries and intend to travel to neighbouring countries to promote our programs in the future.

Building strong research and academic collaborations with international partners has been at the forefront of our international relations strategy. Towards this end, we now have two ongoing joint doctoral programs with two Australian Universities, namely Swinburne University of Technology (SUT) and Deakin University (DU). While the JDP with SUT was initiated in 2017, the JDP with Deakin U was established in 2021. Currently, we have 56 scholars doing their research work & 14 scholars have already graduated under IITH-SUT JDP. We have 11 scholars who joined in 2021 and 10 students offered this year under IITH-Deakin University JDP. To attract bright students to these JDPs, we are advertising separately.

IITH has a very strong research collaboration with Japan through JICA. Recently we have established Japan Desk as a one-stop service to facilitate the various IITH-Japan bilateral activities. FRIENDSHIP 2.0 program is started to establish a sustainable research collaboration network between IITH and Japanese universities and industries. Thereby it will contribute to the human resources development and value creation that meet not only the social requirements of both countries but also Sustainable Development Goals.



**I believe we can speak with one voice.**

- Hon'ble Prime Minister of India  
Shri Narendra Modi

We are also initiating a discussion with National Tsing Hua University, Taiwan to expand the collaboration between IITH and NTHU and enable the Joint Doctoral Program.

International Collaboration is an important aspect and responsibility of the Office of International Relations. We would like to concentrate more on faculty collaborations and Smart Research mobility by Introducing more Joint Doctoral programs, promoting Joint supervision programs along with foreign researchers, and research exchanges. By hosting more International Faculty thru' initiatives like SPARC, VAJRA, and GYAN, we hope to increase the International faculty and students' footprint on our campus. Faculty and students play an important role, and we look forward to their continuous support.



# Theme Diary

## Smart Mobility @IIT Hyderabad

Prof Rajalakshmi P  
Department of Electrical Engineering &  
Project Director, TiHAN-IITH

KID: 20220202

IITH has many Smart Mobility initiatives, including RnD, skill development, and entrepreneurship activities. As part of many funded projects from DST, Meity, DRDO, and Industries, various activities are carried out at IITH. Recently Department of Science and Technology (DST), under the National Mission on Interdisciplinary Cyber-Physical Systems (NM-ICPS), Government of India has sanctioned the prestigious Technology Innovation Hub to IIT Hyderabad in the technological vertical of Autonomous Navigation and Data Acquisition Systems (UAVs, ROVs, etc.) (TiHAN).

### TiHAN Testbed on Autonomous Navigations (Aerial & Terrestrial):

IITH has made a magnanimous effort in building a unified and first of its kind state-of-the-art Testbed to develop autonomous navigation technology for ground and aerial vehicles. The testbed is one of the collaborative platforms with Industry/ Academia/ R&D labs in our endeavours aiming at translational research & commercialization of technology development at both national and international levels.

The Facilities, as shown in **Figure 1 & Figure 2**, include Proving Grounds, Test tracks, Mechanical integration facilities like Hangers, Ground control stations, Anti-drone detection systems, State of the art Simulation tools (SIL, MIL, HIL, VIL), Test tracks/circuits, Road Infra - Smart Poles, Signalized & Unsignalized Intersections, Environment Emulators like Rainfall Simulators, V2X Communications, Drone Runways & Landing area, Control Test centres.

### Technology developments:

**UAV:** In Nano/Micro category drones, Bio-Inspired drones like Quad-wing UAV (Dragonfly based) and Flapping Wing Micro Aerial Vehicles (Aerial Birds based), Nano drone swarms are being developed as in **Figure 3**. In Medium/Large category drone, the focus is on developing solutions air cargo (**Figure 4**), urban air mobility, etc., as a means of solving traffic congestion in the downtown of large cities. In medium category drones (**Figure 5**), high-end sensors like hyperspectral, multispectral cameras, RGB cameras, and LIDAR are integrated for various applications like agriculture, land survey, health monitoring, etc.



Figure 2: Test-tracks for Autonomous Vehicles



Figure 3: Bio-Inspired Drones



Figure 4: Heavy payload Drone – Air cargo



Figure 1: Mechanical Integration facility for UAV testing including control room



Figure 5: Small category drone with Hyperspectral camera (L) & Lidar (R)

# Theme Diary

UGV: ADAS features are built into passenger vehicles, campus shuttles, and bicycles (for last-mile connectivity). ADAS features include pedestrian detection, emergency braking, LDWS, and LKA. They used a test scenario of ADAS function assessment in the SIL framework for an Indian setting. GPS-based autonomous navigation for drive-by-wire enabled vehicles using waypoints. Algorithms for obstacle avoidance and path planning are being developed, as in **Figure 6 & Figure 7**.

## UAV and UGV Training Kits:

UAV and UGV training kits are developed in-house for skill development programs. It is easy to assemble a DIY [Do It Yourself] kit that can be used by students and others interested in working with UGV and UAV, as shown in **Figure 8 & Figure 9**.

## Human Resource & Skill development:

IITH has established a New Interdisciplinary 2-year M. Tech program on Smart mobility (SM) from Aug 2020. Students from multiple departments like Artificial Intelligence, Civil Engineering, Computer Science and Engineering, Design, Electrical Engineering, Mathematics, Mechanical and Aerospace Engineering, and maths are eligible to apply for this program. The first batch of Smart Mobility students SM20 batch has got 100% placement during the campus placement by core companies in the area of mobility.

Also, 24 Doctoral fellows have joined from multiple departments, including EE, CSE, CIVIL, AI, and MAE, and are working in the area of Autonomous Navigation and Data Acquisition. 4 Post-Doctoral Fellows are working in this area.

Prof. Srikant Saripalli, Professor from TAMU, is the TIHAN Chair at IITH in the area of Autonomous Navigations.



Figure 6: Electric Car with LiDAR assisted Pedestrian Detection & Emergency Braking in Testbed (Above) & Autonomous/ Smart Campus Shuttle E-Card (Below)



Figure 7: Electric Bicycle with autonomous driving enabled in Testbed at IITH

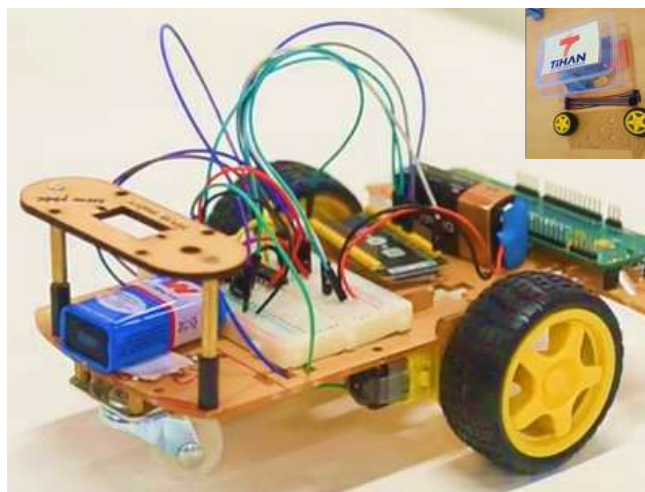

Figure 8: UGV kit developed by TIHAN Skill Development Team



Figure 9: UAV kit developed for skill development



# Research Diary

## 5G and Edge Computing assisted Mission Critical ITS Applications

Dr Antony Franklin (R), Associate Professor, and Ms Shwetha Vittal (L), PhD Scholar, Department of Computer Science & Engineering

KID: 20220203

We are living in a world with breathtaking technological innovations. Starting from self-driving cars to remote robotic surgeries in healthcare, there is no dearth of inventions. With these creative inventions uncovered every minute to improve the standards of living, there is a constant need for the fuel that will enable these technologies to function at their maximum potential. "The Internet, like the steam engine, was a breakthrough that changed the world"-Peter Singer, no doubt. But, we would not be wrong to state that "5G is the breakthrough that we all needed to enable the rapid advancements in technology in the 21st century". It enables a new kind of cellular broadband that is designed to connect virtually everyone and everything together, including machines, objects, and devices.

Current advancements in 5G and edge computing infrastructure increase the need to deploy location-based services for mission-critical and delay-sensitive applications like Vehicle to everything (V2X) and Intelligent Transport System (ITS). Research shows that human error is completely or partially the cause of accidents in most cases. And due to this, V2X communication has been continuously researched for more than a decade now with respect to safe transportation.

In this context, 5G and Multi-access Edge Computing (MEC) based Location Services (LCS) can assist the emergency services by providing the exact location of the caller/user to the authorities and first responders.

We, a team of members from Networked Wireless Systems Lab (NeWS Lab) at IITH, have built an end-to-end 5G-MEC assisted Location Services system. This system can aid the emergency services accessing authorities or the first responders like Police, Ambulance, and Fire Control to fetch the location of the caller/user in need of assistance. Our 5G-MEC coupled testbed, as shown in **Figure 10 and Figure 11**, addresses the need for location assistance in mission-critical, delay-sensitive, and emergency services in ITS and V2X by building an end-to-end LCS emulation framework. Our LCS framework is flexible to be deployed in the remote cloud and edge environments.

The 5G network aids in delivering the current location information of the user to the ITS emergency services running at the MEC running at the end of the network.

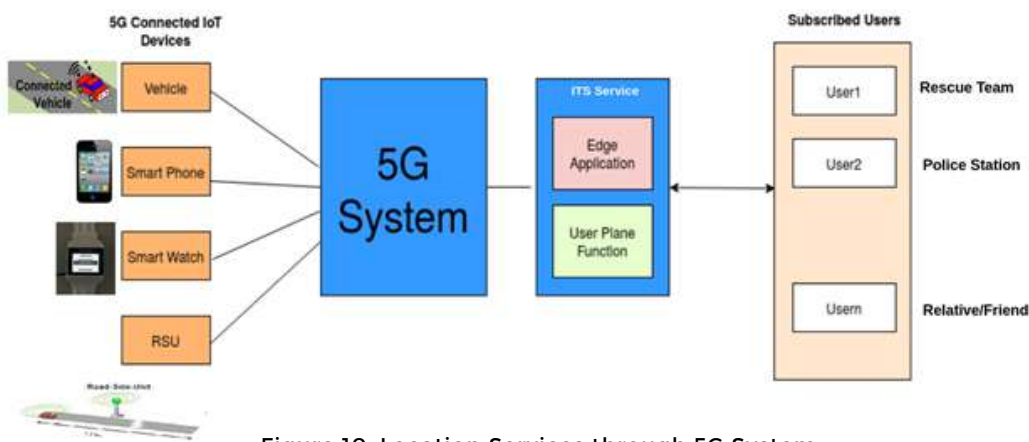

Figure 10: Location Services through 5G System

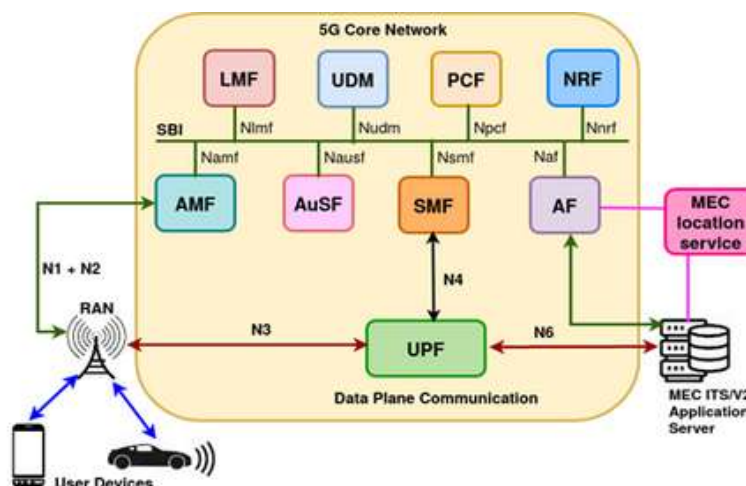

Figure 11: 5G System Architecture for Location Services



# Research Diary

5G connected devices like smartphones, vehicles, and IoT devices (e.g., wearables) can avail the benefit of this service using an application running on these devices, which can request the location services required for the emergency services. The request, along with the associated location information, is sent to the ITS server via the 5G network. Additionally, the ITS application itself can request the user to provide its current location to enhance the emergency services response. Using this, the ITS application can assist the user in reaching a safe location at times when the user does not know where and how to reach a safe location.

Human safety, as well as the safety of materials, are vital and a necessary component of any armed forces organization. LCS with ITS can assist in close monitoring of the location of Infantry Fighting Vehicles (IFVs) and suspect the entry of intruders in the remote military/navy zones.

We have sample applications on ITS working using our testbed. The details of it can be availed from the recent demonstration we had at IEEE International Conference on Network Softwarization. <https://youtu.be/wxirflvpTjc>.

In addition to on-road transportation assistance, LCS can be quite useful in Ocean Networks, too, with a private 5G deployment, as illustrated in **Figure 12**. Offshore fishing is a common occupation providing a livelihood for tens of millions worldwide. Lack of timely warning can lead to missing fishing vessels, collisions between ships and boats during night times, bad weather, lack of offshore communication resulting in late information/message arrival to their families, and so on. In this regard, a 5G-based LCS system can assist in building a maritime safety information communication system, tracking fishing vessels with the fishing vessel to shore (V2I) and fishing vessel to vessel communication (V2V), Maritime IoT, and local community network for fishermen.

The observance of 'safety first, safety always' is intended to strengthen the professional approach to enhance combat capability. It also strongly aligns with the Digital India initiatives and is a key driver for economic growth and technological development in India, and we are more than glad to have played a role in it.



Figure 12: LCS assisted IFVs & Ocean Networks using Private 5G

## Research Diary

### Heterogeneity in the Driver Behavior: An Exploratory Study Using Real-Time Driving Data

Dr Digvijay S Pawar (L), Assistant Professor

Ms Jahnavi Yarlagadda (R), PhD Scholar

Dept of Civil Engineering

KID: 20220204



Road traffic accidents are one of the leading causes of death, resulting in approximately 1.35 million deaths every year [WHO, 2018]. The factors associated with road crashes have been studied over decades, and driver behaviour is concluded to be the major contributory factor. Therefore, understanding the driver's behaviour is important for many applications like driver assistance or personalized feedback provision for enhancing driving safety, economy, and comfort. In addition, the implications of driver behaviour research are significant inputs for the design of autonomous vehicles. Driver behaviour indicates the manner of executing various driving tasks, which can be perceived as controlling the vehicle in the longitudinal and lateral directions.

The habitual way of performing driving manoeuvres is considered a driving style, which characterizes the individual driver or a group of drivers. Many researchers have attempted to classify the drivers and the driving styles based on the outcomes of driving tasks from the perspective of driving safety.

In this context, the study investigates the extent of variations in the individual's driving styles during routine driving. The driving styles are conceptualized using the vehicle kinematic data, that is, speed and accelerations performed during longitudinal control.

The data is collected for 42 professional drivers using instrumented vehicles over a defined study stretch. An algorithm is developed for data extraction, and a total of 7548 acceleration and 6156 braking manoeuvres and corresponding driving performance features are extracted. The driving manoeuvre data are analyzed using the unsupervised techniques (PCA and K-means clustering), and three patterns of acceleration and braking are identified, which are further associated with two patterns of speed behaviour. The results showed that each driver is found to exhibit different driving patterns in different driving regimes, and no driver constantly shows safe or aggressive behaviour. The aggression scores are found to be different among drivers, indicating behavioural heterogeneity.

# Research Diary

This study's results demonstrate that drivers' level of aggression in different driving regimes is not constant, and characterizing the driver by means of abstract driving features is not indicative of diversified driving behaviour. The proposed method identifies the individualized driving behaviours, reflecting the driver's choice of driving manoeuvres, as shown in **Figure 13** & **Figure 14**. Thus, the insights from the study are highly useful for designing driver-specific safety models for driver assistance and driver identification.



Figure 13: (a) Instrumentation details; (b) Study vehicle; (c) Recorded speed and acceleration profiles; and (d) snapshots of collected video data.

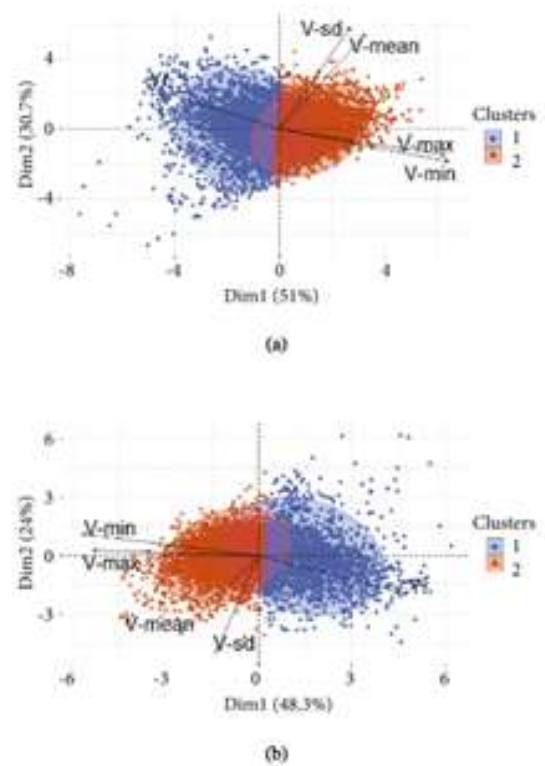

Figure 14: Cylindrical imperfection measured using DIC

# Research Diary

## Catalyzing Autonomous Navigation Design Thinking across India

Dr G V V Sharma, Associate Professor (R)  
Dept of Electrical Engineering

Mr Chandrakumar Chettiar (CK) (L),  
MD, CEO, Optimuslogic Systems (India) Pvt. Ltd.

KID: 20220205



### Introduction:

Drone (UAV) is probably the most exciting and widespread innovation today. Whenever and wherever a drone flies, it always catches our attention and excites our imagination towards autonomous drones doing a lot of work for us.

As Indians, an autonomous drone does not surprise us, thanks to the "Pushpak Vimana" mythology of Ramayana - A flying machine that can go anywhere on command on autopilot, originally belonging to Kubera, the God of Wealth, stolen by Ravana, and restored back to its original owner by Lord Rama as illustrated in **Figure 15**.

In modern times, it is Tesla that has shown the world how autonomous navigation can happen in the real world and it works. As the market grows, more and more vehicle manufacturers are adopting autonomous navigation and driver aids in some form or other.

TiHAN-IIT Hyderabad is on this mission to accelerate autonomous navigation space in India by creating an atmosphere of innovation, training new talent to understand and implement solutions, and encouraging companies and start-ups to use its facilities to build and test terrestrial and aerial autonomous navigation enabled products.



Figure 15: Pushpak Vimana - India's 1st Autonomous Drone

# Research Diary

## OptimusLogic and TiHAN-IIT Hyderabad:

OptimusLogic Systems, since 2013, with operations in Hyderabad & Bengaluru in India, is now a growing global Original Device Manufacturer (ODM) and Independent Design House (IDH) in India for Mobile & Wearable AI systems, Industrial IoT solutions, Signal Intelligence Radars, and Ad-hoc Radios.

OptimusLogic has had an R&D partnership with IIT Hyderabad since 2016 to tap into the latest academic research & talent across engineering and research disciplines. OptimusLogic and TiHAN-IIT Hyderabad jointly develop solutions, training programs & kits for autonomous navigation in aerial and terrestrial vehicles.

Over the past quarter in 2022, TiHAN-IIT Hyderabad and OptimusLogic have worked together to create awareness and impact in the autonomous navigation space with:

- UAV, UGV Training Kits
- Training Programs
- "Vaman" for AI in Autonomous Navigation - 1st mass-produced academia-industry product in India, as shown in **Figure 15**.

## UAV & UGV Kits:

TiHAN-IIT Hyderabad and OptimusLogic partnered to build Unmanned Ground Vehicle (UGV) & Unmanned Aerial Vehicle (UAV) kits designed explicitly for Skill Development Activities of Hub and facilitate the commercial availability from industry partners of UGV & UAV kits, as shown in **Figure 17 & Figure 18**, which will benefit utilization by target institutes, industry, and student enthusiasts.

In an industry-academia co-operation first, the partnership created commercially viable kits that enable learning and skill development, as well as to maintain the revenues to keep the program sustainable for long-term goals.

These kits, along with the training programs, enable participants to:

- Understand and learn industry focus for better jobs across:
  - Hardware • Software • Firmware • VLSI • FPGA • AI+ML Applications
  - Wireless RF • System Design • Assembly • Debug • Testing using
  - C • Python • Java • Android • Linux • Windows • RPi • Arduino
  - Build a working UAV/UGV system from scratch and understand each component across multiple engineering streams
  - Prepare and get a direction for industry jobs and career opportunities

Kits can be bought and leased from Optimus Electronics, a distributor for OptimusLogic systems, by email at [vaman@optimuselectronics.com](mailto:vaman@optimuselectronics.com) or by contacting the coordinator at the IIT Hyderabad campus at +91-9606706303. Online sales are coming soon.

## Training programs:

TiHAN-IIT Hyderabad conducted multiple workshops across engineering colleges, where participants - that included teachers and students experienced the joy of building and testing their own UAVs and UGVs, as depicted in **Figure 19** (from L-R-B: Students from Anurag University, Hyderabad, NIT, AP, Tadepalligude, and CBIT, Hyderabad).

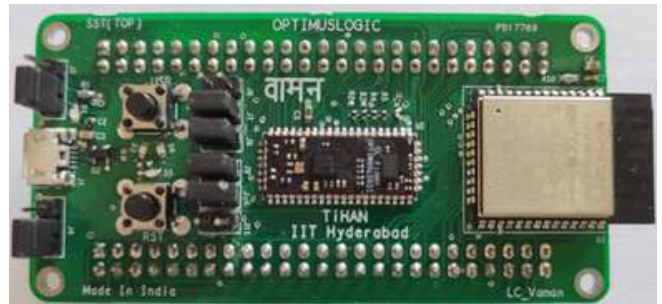

Figure 16: TiHAN-IIT Hyderabad OptimusLogic "Vaman" Board

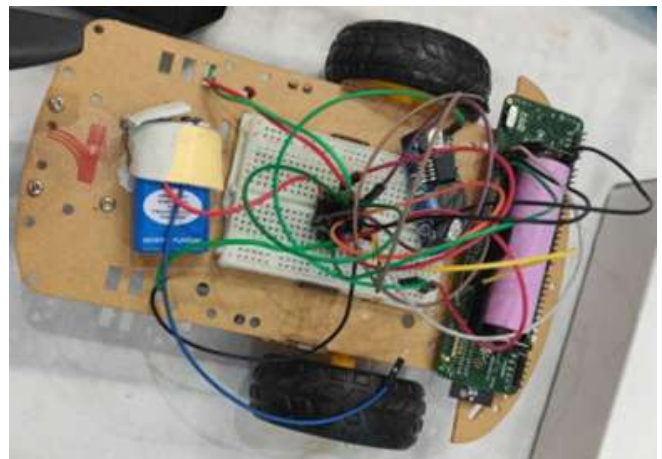

Figure 17: LCS assisted IFVs & Ocean Networks using Private 5G



Figure 18: LCS assisted IFVs & Ocean Networks using Private 5G



Figure 19: Students Building & Testing their own UAVs & UGVs

# Research Diary

## Vaman (वामन) for AI in Autonomous Navigation:

TiHAN-IIT Hyderabad, in association with OptimusLogic Systems India, launches the “Vaman” range of affordable **Made-in-India** boards to enable innovation in autonomous navigation systems in UAVs/UGVs through a significant impact across the engineering curriculum and mindset and contribute to the rising semiconductor ecosystem in India and the world.

TiHAN-IIT Hyderabad’s “Vaman” redefines what can be achieved with Industry-Academic cooperation for a single Board, mixed with passion and commitment to Open Source coupled with local affordable design & manufacturing.

### The VamanLC 1.0 Board features:

- The “Pygmy” as shown in **Figure 20**, FPGA+ARM+AI Module, Made-in-India, made by OptimusLogic
- Espressif ESP-32 WiFi+BLE Module to provide wireless connectivity and programming
- Micro-USB Port for Power, Programming, and Wired Interfacing
- 50+50 (100) 2.54mm Pins for a wide variety of uses and flexibility
- 100% Open-Source VLSI, Hardware, Software, and AI/ML Tools chains that run on Android, Raspberry Pi, Laptop, and PC
  - VLSI & Hardware:
    - Google-supported QuickLogic Corporation’s Open Reconfigurable Computing (QORC)
    - Symbiflow, Yosys RTL Synthesis, VPR Place/Route
    - KiCad PCB Design
  - Embedded Systems & AI/ML
    - GCC, Zephyr RTOS, FreeRTOS
    - TensorFlow Lite, SensiML
- Local Manufacturing & Support System for scale and supply
- Industry Relevant Training to target semiconductor career opportunities

The TiHAN-IIT Hyderabad VamanLC Board uses tools that can run on your Android Phone without needing a Laptop/PC, increasing its reach across the country and cutting across economic and social divides. Anyone now can learn, master, and build solutions to real-world problems with a hardware-software co-design thought process from prototypes to products.

The Vaman LC can be used as a learning platform to deliver industry-relevant content suitable for career development in the Semiconductor & Electronics industry across Graduate/Post-Graduate Engineering & Science Disciplines (IIT Hyderabad has used it for courses since 2021):

- Hardware, Software, Firmware Co-Design
- Digital Design, VLSI, FPGA
- DSP Design & Implementation
- AI+ML Applications
- System Design
- Assembly
- Debug
- Testing & Validation

The Vaman LC serves as a ready platform used for the development of products such as:

- Systems in UGVs, UAVs
- Wearable AI Systems
- Consumer & Industrial IoT
- Low Power Ad-hoc Communication

The VamanLC Board is the first product of long-term global academic-industry cooperation in India, with IIT Hyderabad (under the aegis of Dr GVV Sharma), TiHAN (under the aegis of Dr Rajalakshmi Pachamuthu & Mahesh Balaiah Aswathaiya), OptimusLogic Team (led by Chandrakumar Chettiar, Someshwar MS, Krishnakumar A) and QuickLogic Corporation (led by Brian Faith & Tarachand Pagarani).

VamanLC Board complements the TiHAN-IIT Hyderabad UAV/UGV Kits for advanced learning and development.



Figure 20: OptimusLogic’s Pygmy Stamp

**Based on the success of “Vaman” products, OptimusLogic and IIT Hyderabad are working for India’s 1st homegrown 5G Global mobile phone, coming in 2023.**



# Research Diary

## Open-air Off-street Vehicle Parking Management System for IITH using Deep Neural Network

Prof C Krishna Mohan, Dept of CSE (L)  
Dr Digvijay S Pawar, Dept of Civil Engg. (M)  
Mr K Naveen Kumar, PhD Scholar, Dept of CSE (R)  
KID: 20220206



Smart parking solution aims to output real-time parking occupancy information. It helps to reduce parking bay search time, traffic, fuel consumption, and thereby vehicular emissions with increased road safety. A computer vision-based solution using camera video data is the most reliable and rational since it allows monitoring of the entire open-air parking area at once. A real-time parking solution (cloud-based, server processing, or onboard processing) helps bring the occupancy information to the end-user.

It comes with many challenges such as viewing angles, lighting conditions, model optimization, reducing inference time, and many more real-world challenges. Also, the earlier research works focus on day-time data and do not discuss the night data. So, in this work, we perform experiments on real-time 24-hour data from an input camera video source mounted to monitor parking at IIT Hyderabad (IITH) parking lot.

The IITH parking dataset contains 24 hours of video data recorded at the IIT Hyderabad open-air parking area. We capture the video data using a Hikvision Exir mini bullet network camera at 20 frames per second with 5MP resolution. We have installed the camera at the height of 25 meters on a seven-story institute building (Block-C). The camera angle is adjusted to capture the entire parking area with 91 parking bays, as shown in Figure 21. We manually annotate a single frame with polygon-shaped spatial regions to capture the perfect bay areas. We use the Labelme tool for manual annotation. We monitor the spatial regions of each bay marked in the parking area for the entire duration of the video. We observe that a 10-second interval could capture a complete parking behaviour, including the peak hour occupancy. Hence, we sample the 24-hour video data at one frame out of 20 frames per 10 seconds.

This data sampling resulted in 6 frames per minute and a total of 8640 frames (24hrs x 60minutes x 6 frames per minute). Further, as each frame consists of 91 spatial parking bays, we obtain a total of 786240 spatial regions (24hrs x 60minutes x six frames per minute x 91 bays per frame) for further processing. Finally, we manually inspect each of the cropped spatial regions and bucket them into the empty or occupied categories to train a supervised deep neural network.

The dataset consists of polygon-shaped bays cropped from a set of data frames sampled from the manually annotated live-camera feed video data. Polygon-shaped bays perfectly capture the viewpoint variations caused due to the input camera angle. However, the extra black areas add noise to the polygon-shaped bay data, as shown in Figure 22. They are not suitable for feature extraction and model training. Hence, it is necessary to remove the noise (black areas) by transforming the polygon-shaped bays into perfect rectangular data samples, as shown in Figure 22. We consider the perspective transform method for our preprocessing. Further, we use perspective transform on the original polygon bay points and the above-defined four points to obtain the transformation matrix. Finally, we apply the transformation matrix to the polygon-shaped parking bays to get the transformed rectangular bays, as shown in Figure 22.

Further, we use these transformed bays for our model training. We design a four-layered convolution neural network (CNN) architecture followed by two fully connected layers for the empty bay classification.

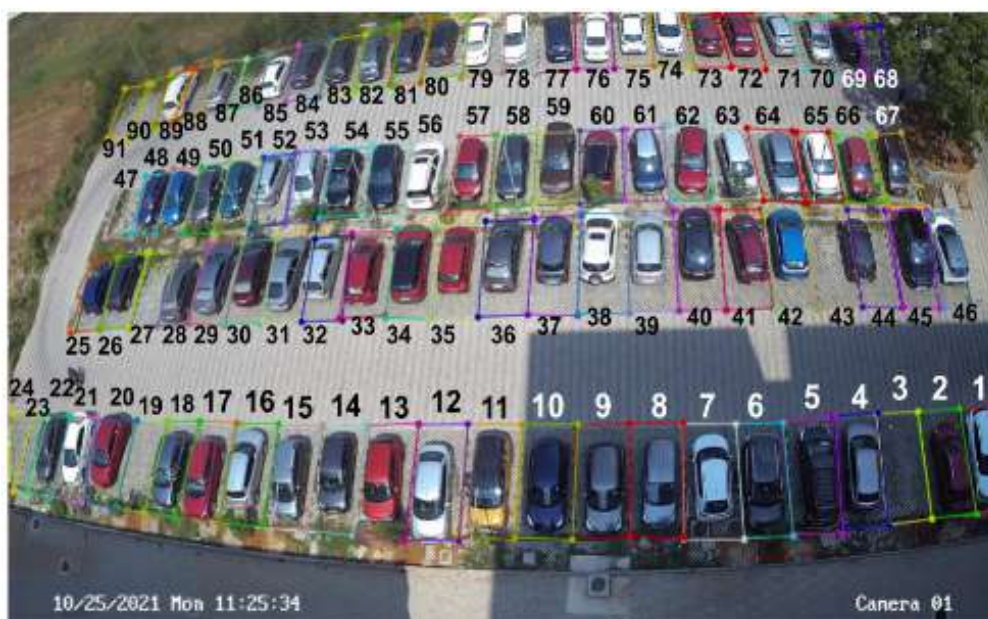

Figure 21: IITH (Block-C) parking lot

# Research Diary

**Figure 23** shows the real-time occupancy performance and corresponding confusion matrices of day and night data. However, our proposed CNN model achieves an accuracy of 99.8% on test data, we observe an accuracy drop of ~ 3 - 7% while testing on real-time data. This is due to the effect of different lighting conditions (shadows).

We analyze the per-hour & per-bay parking occupancy using our proposed architecture, as shown in **Figure 24**. We observe a bell-shaped occupancy curve highlighting the peak hour occupancy, which matches the real-world scenario. the efficiency of the parking area.

Our proposed CNN model gave a test accuracy of 99.8%, one limitation is the accuracy drop of ~ 3 - 7% on real-time inference due to different lighting conditions of the day. Hence, in the future, we would like to apply semi-supervised learning algorithms to combine both less annotated and a large amount of unannotated parking data to improve real-time performance. Also, we plan to deploy the solution on edge hardware and provide real-time parking occupancy information to the IITH parking lot users.

## Reference:

K. Naveen Kumar, Digvijay S. Pawar, and C. Krishna Mohan. "Open-air Off-street Vehicle Parking Management System Using Deep Neural Networks: A Case Study." In 2022 14th International Conference on COMMunication Systems & NETWORKS (COMSNETS) ITS Workshop, pp. 800-805. IEEE, 2022.

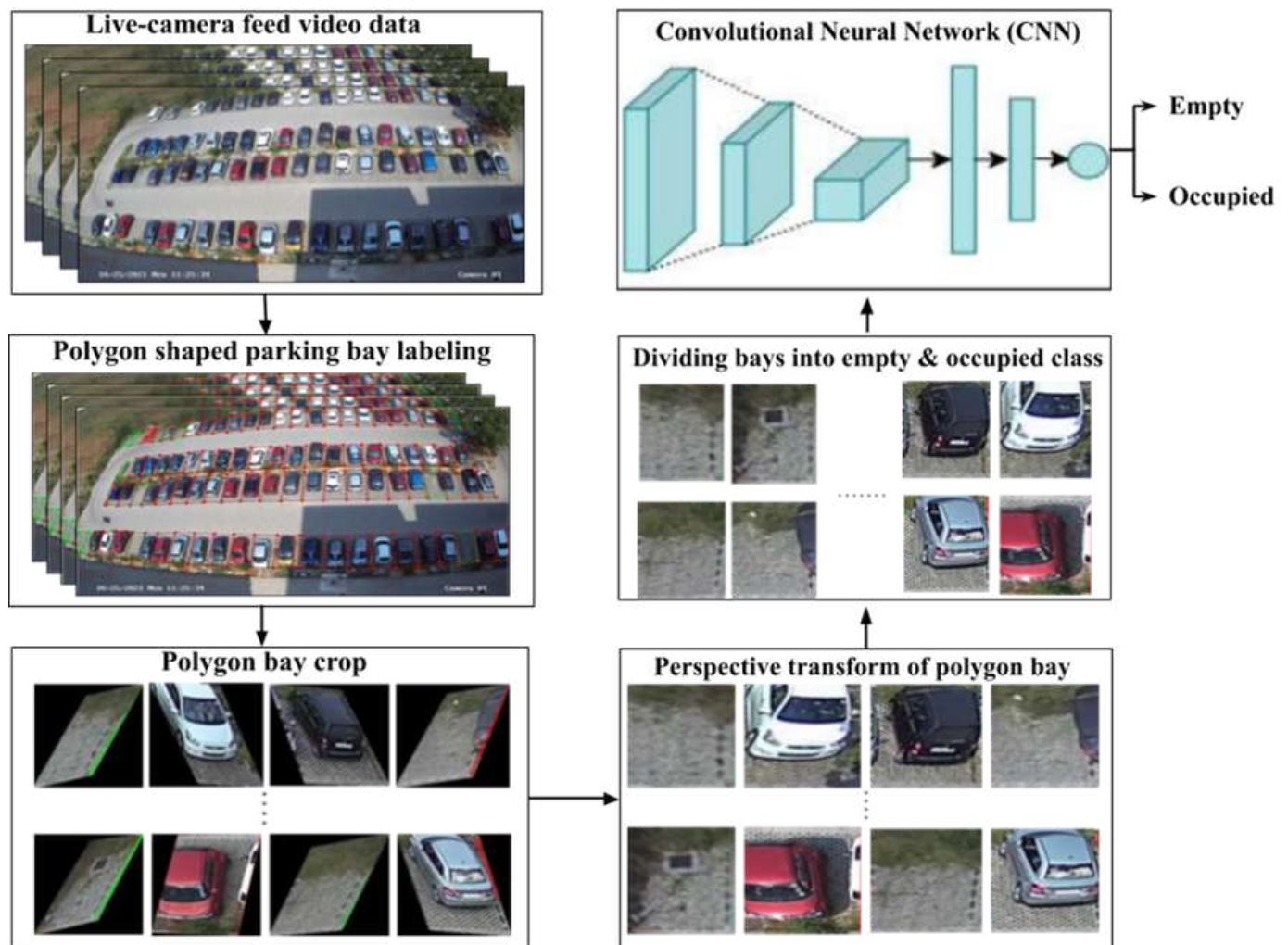

Figure 22: Block diagram of the proposed approach. We manually annotate the spatial bay regions of a single frame obtained from the live-camera feed video data and extract the polygon-shaped bays. Further, we apply the perspective transformation on polygon bays to remove noise and convert it into perfect rectangular samples. Finally, the samples are manually bucketed empty and occupied and sent into a deep neural network for model training.

# Research Diary

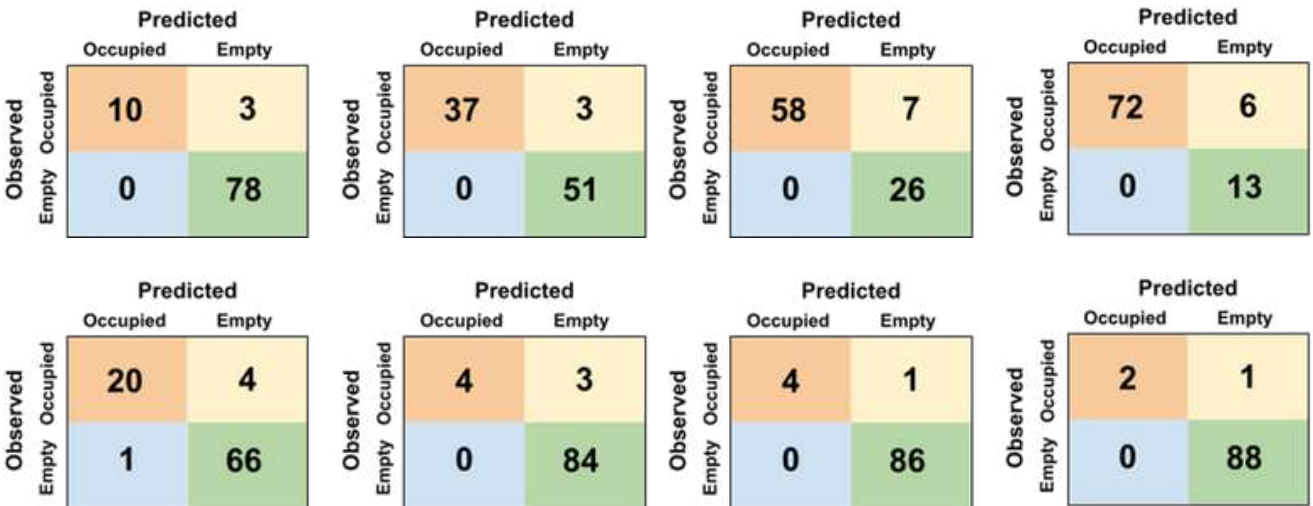

Figure 23: Day-time & Night-time occupancy analysis at regular time intervals and corresponding confusion matrices. Time is represented in the format hh:00:00.

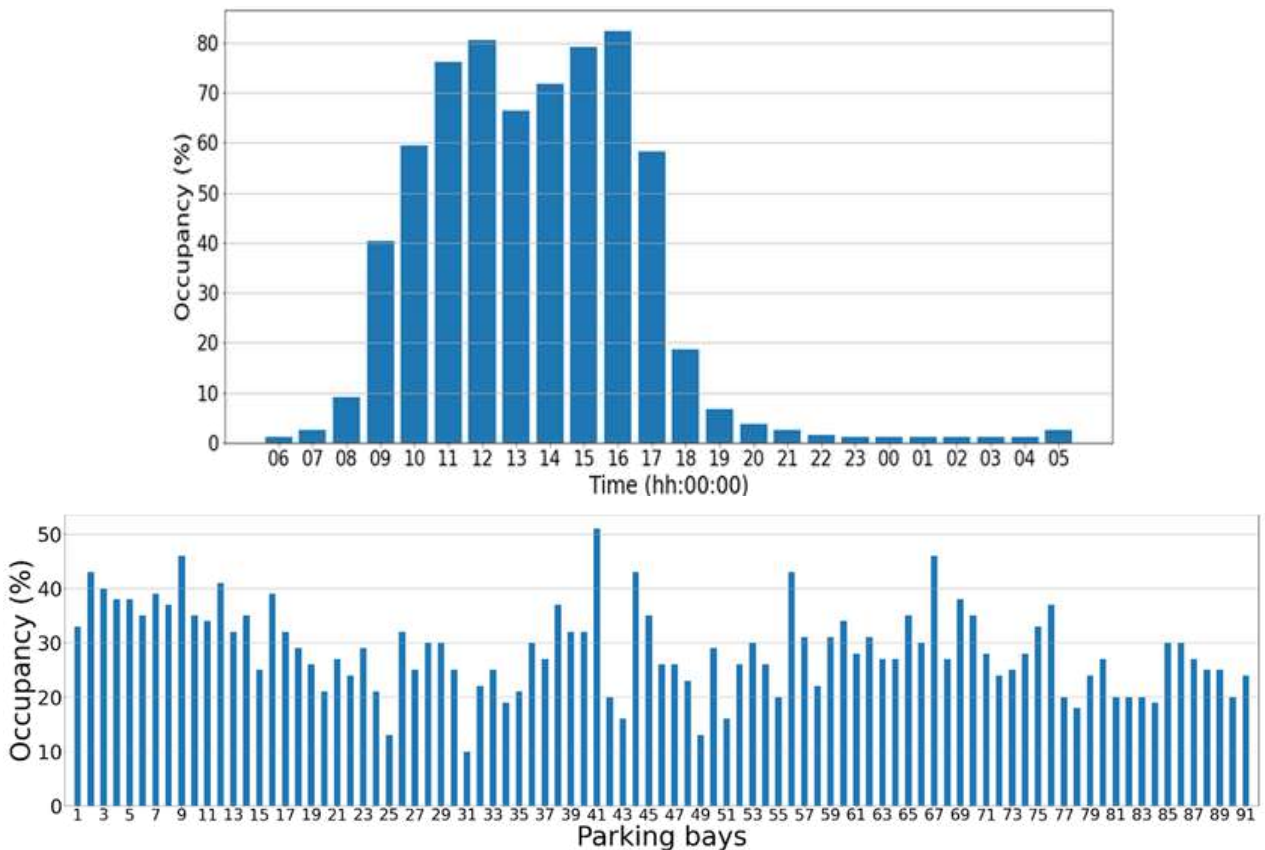

Figure 24: Per-hour & Per-bay occupancy analysis



# Research Diary

## Distributed and Federated Learning

Dr Shashank Vatedka

Assistant Professor

Department of Electrical Engineering

KID: 20220207

"Any sufficiently advanced technology is indistinguishable from magic" - Arthur C Clarke

If you watched cartoons during the 90's, then you would remember a futuristic sitcom called the Jetsons, which had flying cars, jetpacks, autonomous navigation, and robots doing household chores. While we are far from being in this technological utopia, the future of navigation is certainly heading towards connecting vehicles, autonomous navigation and UAV-based systems. Achieving these would require significant progress in various fields ranging from the design of specialized sensors and hardware, AI/ML, and communication systems to engines, aerodynamics and design. There has been a lot of exciting research in recent years, particularly by groups at TIHAN and IITH, towards making these dreams a reality.

Let us take machine learning, which has emerged as one of the hottest topics in recent years. There have been great strides made in the areas of object detection, computer vision and natural language processing. However, there are new challenges that are unique to the problem of autonomous and connected vehicles. If we are to make transportation "smarter," vehicles have to be fitted with a variety of sensors, including cameras, RADAR, LIDAR, GPS, etc., and the data generated by these are used to train deep learning algorithms for navigation, route planning, traffic control and infotainment services. However, each car can now generate several gigabytes of data in just a few hours, which is a lot to communicate and process and can contain sensitive information that needs to be kept private.

A majority of the work on machine learning today assumes that all the training data is available at one place (aka a centralized server), which is not true in the setting above. The training data is actually generated by various devices (or "clients") that are distributed, whereas the machine learning model is to be obtained at a centralized server which is connected to each of the clients typically through noisy/communication-constrained links. The need of the hour is to design algorithms for learning reliable models at the centralized server in a setting where client data is to be kept private, and the amount of communication between the clients and the server is limited. To solve this problem, there has been a flurry of recent work in emerging fields of distributed and federated learning [1,2]. This has led to several new problems and cross-fertilization of ideas in various areas, including distributed optimization, machine learning, cryptography, security, information theory, and statistics, just to name a few.

To give a very brief overview of the main challenges, contrast this with the standard supervised machine learning problem where we have labelled data, and the goal is to typically train a model such as a neural network using this data. In the setting mentioned previously, the data is instead distributed across a large number of clients. A naive solution would be to ask the clients to send all their data to the server and then use this to train the model.

However, this approach would be extremely communication-intensive, insecure, and violate privacy requirements.

The fundamental idea behind federated learning is that clients can instead train "local" models (say, neural networks) using their personal data and share this with the server, who now somehow aggregates the models and sends them back to the clients.

This is a very simplistic description that does not capture the nuances involved in the process, but the typical cycle used in federated learning is as follows:

1. The server selects a subset of the clients and broadcasts a coarse/current "global" model to these clients,
2. The clients use part of their personal data and the model shared by the server to train separate updated "local" models,
3. The local models are then compressed and sent to the server
4. The server aggregates these local models to update the current model
5. Go back to step 1, and refine the model

There are a number of challenges involved in this process: the data of the various users can be very heterogeneous, the local models must not leak information about the user data, clients are not always available, and the communication links between the clients and the server can be very noisy, the systems are susceptible to attacks, and so on. In fact, each step of the process gives rise to very interesting and challenging fundamental problems.

Our group has been recently studying problems of compression and communication-efficient aggregation in the above context. However, the field has a very rich set of open problems, and we can only scratch the surface.

### References:

[1] Kairouz, Peter, et al. "Advances and open problems in federated learning." *Foundations and Trends® in Machine Learning* 14.1-2 (2021): 1-210.

[2] Elbir, Ahmet M., Burak Soner, and Sinem Coleri. "Federated learning in vehicular networks." *arXiv preprint arXiv:2006.01412* (2020).

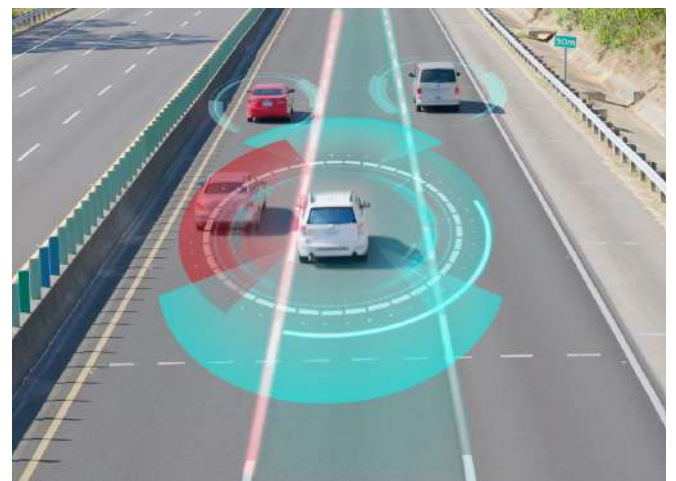

Figure 25: Representation Image of Lidar Technology



# Research Diary

## Design and Fabrication of Autonomous Passenger Drone

Prof Venkatesham B

Department of Mechanical & Aerospace Engineering

KID: 20220208



Drone technology has witnessed remarkable developments over the past decade. The military, logistics, agricultural, healthcare, and entertainment industries have demonstrated extensive use of unmanned aerial systems. Additionally, advancements in electronic technology have made autonomous drone research and development economically feasible. It is anticipated that autonomous manned aerial vehicles will become indispensable for urban transit and disaster management in the future. This project aims to design and build a passenger drone with complete autonomy. This unmanned aerial vehicle would be powered by rechargeable batteries and could take off and land vertically.

A modular design concept was developed for autonomous passenger drones, as shown in **Figure 26**. There are three significant modules existing in the proposed concept which are the vehicle with the power unit, the autonomous navigation system, and the passenger cabin. A hexadecopter configuration has been found to be appropriate for a given payload based on commercially available motor and propeller units. Various scenarios of operating the passenger drone from the user's perspective have been shown. Cabin designs have been shown with mock-ups to understand the design language and use case scenarios. We demonstrated a combined system of IMU odometry and visual odometry, called the Visual Inertial Navigation System (VINS), which is an optimization framework for odometry. Odometry integration with LiDAR is in progress to detect the obstacles. A simple and easily adjustable airborne Mobile Mapping System (MMS) to observe the environmental data with sensor fusion was developed.

We tested various state estimation methods involving only GPS, GPS + IMU, Monocular Camera + IMU based odometry, and stereo Vision-based approach with different Mapping techniques like octo Map and RTAB Map. We have built Autonomous navigation and avoidance system that generates a smooth collision-free trajectory based on gradient-based approaches and developed a long-range Obstacle Avoidance system to avoid structures such as buildings from a distance afar using a Monocular camera and a Deep Network.

Monocular visual-inertial navigation for urban scenes is another pipeline we developed to tackle challenges of planning and localization involving bad GPS, invisible ground planes, and texture-less areas where standard methods of localization are known to drift away, and also tackled planning challenges involving uncertain Map, tight spaces and SLAM failure.

Simulation studies were conducted for long-range wireless communication links using a combination of standard environments. A small-scale drone assembly project is underway, with ground testing set to begin this month. A multi-disciplinary team from IIT Hyderabad, IIIT Hyderabad, and IIIT Sri City collaborated to execute the current project.

Team members:

- Dr B Venkatesham, IIT Hyderabad
- Dr Vineet N Balasubramanian, IIT Hyderabad
- Dr K. Madhava Krishna, IIIT Hyderabad
- Dr Raja Vara Prasad Y, IIIT Sri City Chittoor
- Dr Deepak John Mathew, IIT Hyderabad
- Dr Rajalakshmi P, IIT Hyderabad
- Dr R. Prasanth Kumar, IIT Hyderabad
- Dr K. Siva Kumar, IIT Hyderabad
- Dr M. S. Mahesh, IIT Hyderabad
- Mr Rohit Murugesan, IIT Hyderabad
- Mr Mohammad Azizuddin Imtiaz, IIT Hyderabad
- Mr Sanju Kumar, IIT Hyderabad
- Ms Meenakshi Mishra, IIT Hyderabad
- Mr Priyabrata Rautray, IIT Hyderabad
- Mr Rohan Kaushik, IIT Hyderabad
- Mr B. Bhanu Teja, IIIT Hyderabad
- Mr Rishabh Dev Tadav, IIIT Hyderabad
- Mr Sudarshan S Harithas, IIIT Hyderabad
- Mr Harshit Sankhla, IIIT Hyderabad
- Mr Ayyappa Swamy Thatavarthy, IIIT Hyderabad



Figure 26: Virtual design of complete passenger Drone System & Drone structure with cabin



# Research Diary

## World of PAVs

### Practice-based research on Personal Aerial Vehicles

Priyabrata Rautray (L)

Joint PhD Scholar IIT Hyderabad and Swinburne University

Supervisor: Prof Deepak John Mathew (R), Department of Design

KID: 20220209

#### Exploring the forms in Personal Aerial Vehicle designs suitable for mobility in India's growing cities:

In the 21st century, where hamlets and towns are replaced with megacities, the load on the existing road infrastructure is very high, leading to a demand for smooth and efficient transport systems. As a result, there is an opportunity to design and develop alternative modes of a personal transportation system that does not rely on the land infrastructure or add to the existing traffic. Thus, aerial transportation can be faster and less expensive than developing new physical infrastructure.

The technologies involved in Personal Aerial Vehicles (PAVs) have been increasing rapidly over the last decade. We need to understand that PAVs are an entirely new transportation system. With the change in the medium, unique user experiences and challenges will need to be addressed. Thus, this research project aims to understand the users' form perception of PAVs, their needs, wants and concerns, and how to convert them into design parameters for future development. The research will have tangible and intangible outputs that will empower designers to create new PAVs.

This research project is a part of a funded project by the Government of India on the holistic development of PAVs for Indian cities. The group consist of research from various departments like Computer Science, Mechanical and Aerospace Engineering, Electrical and Electronics, Chemical Engineering, Department of Design, etc. As part of the project, these engineering departments will develop the required technologies for PAVs. Besides the essential technical and engineering details, the design parameters are critical for the PAV's overall physical form. Public acceptance and market success depends on how well the design accommodates users' needs, wants, and concerns and can make a crucial difference in their success. This research also tries to reduce or forgo the time taken for an automobile to develop from an engineering device to become more user-friendly and an object of desire. Thus, this research is focused on users' needs, wants and concerns, which can be translated into design parameters to explore the forms for these new PAVs. Even though the development of PAVs is in its nascent stage, it promises to be one mobile device that can create an alternative mode of the personal air transportation system for Indian cities in the near future.

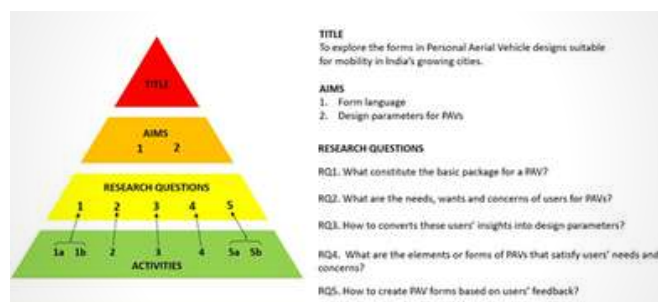

Figure 27: Research Design

The research project was designed so that the research activities formed the base of the pyramid and helped answer the research questions. These research activities include product reviews, storyboarding, Pugh Multi-criteria analysis of VTOL technologies, user surveys, and form surveys, as shown in Figure 27, Figure 28 & Figure 29.

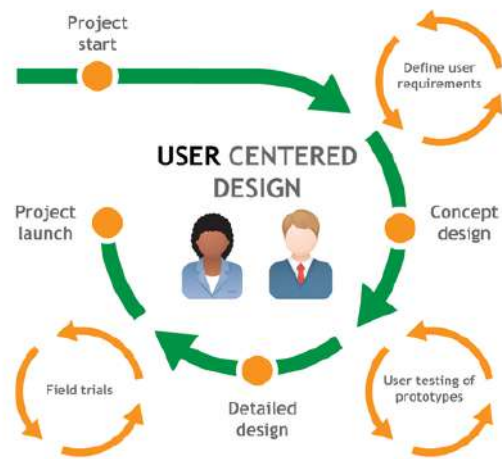

Figure 28: Usercentered design process

Product reviews are valuable information, and better help designers understand their products. Comparing current PAVs highlights various product criteria such as size, VTOL technology, number of passenger carrying capacity, flying distance or endurance, power source, control and form factors. The shape and outlook of PAVs vastly depend on the VTOL technologies and working scenarios used to design PAVs. Thus, the storyboarding method was used to highlight the different working scenarios and understand the requirements of modern cities for PAV operation.

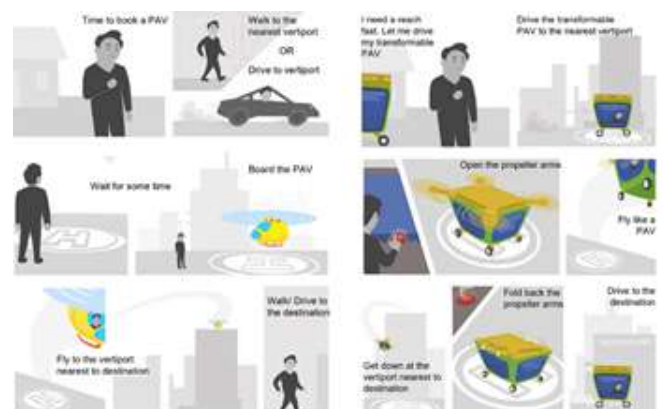

Figure 29: Storybording as research method

# Research Diary



Figure 30: Key areas for users' survey

Designers and researchers have used different methods and techniques to develop new products. Collecting users' data is one of the essential ways to create more user-centric and commercially successful results. Traditionally, a user survey involves evaluative research where users generally evaluate existing prototypes or concepts. In generative research, users' insights are informed to the designers before production. The first online study presents users' needs, wants, and concerns about the PAVs and studies different aspects of the PAVs system and its relation to the user, as shown in **Figure 30**.

This second survey mainly focuses on the visual aesthetic aspect of the current PAVs' product form. To develop a conceptual design, one needs to understand the global trends in designing PAVs and users' perceptions of PAV. In this segment, three methodologies, as shown **Figure 31**, **Figure 32** & **Figure 33**, were used to analyse the product form of PAVs:

**Design Format Analysis (DFA)** - the study of visual elements, form language, identity, design elements, etc., and their relationships and organisation to form a coherent product.

**Form Survey** - A second survey was conducted to understand the users' perception of forms of PAVs.

**Deconstruction** - breaking the product form into constituent elements and studying the relation in shape, size, proportion, and location.

The form survey's objective was to analyse the visual aesthetic aspect of the product form of the existing PAVs and understand the users' perception of PAVs (Chiu & Lin, 2018; Dahlgard Jens et al., 2008; Nagamachi, 2016). The survey was based on the Kansei engineering method, where the user had to select a set of emotive words from a given list to describe the PAVs. Then using the process of deconstruction, the users were shown the outline of the current PAVs form and were asked to select the associated Kansei words. The user data were analysed using four methods: correlation, frequency, DFA and deconstruction, and analysis of answers to open-ended questions. The second survey's findings helped formulate the form parameters and four groups of PAVs based on the form attributes.

The practice-based research method was used to implement the findings of the research activities. This process includes the iterative design process through which seven different concept designs were created for each group. This step is followed by developing form models (scaled model 1:15) out of Polyurethane (PU) foam. A detailed 3D modelling and rendering were done to study the form. Out of twenty-eight designs, one design per group was selected for further form development. These selected models were shown through 3D animation for better perception of form and scale. The artefacts created in this activity were displayed as an exhibition to acquire user feedback on the PAV forms.

Exterior form and Elements				
Passenger Drone	Dharg 114	Alibus Popup	Aston Martin Valante	Augusta Westland Project Zero
Images				
Features/Elements				
No. of passenger	2	2	1	2
Motor	4 Co-axial motor	Detachable Motor	2 180-ohm Motors, 1 Fixed motor	2 180-ohm Motors
Wing type	NA	NA	Fixed wing/body	Fixed wing/body
Landing gear	Fixed landing gear	Detachable drive base	Fixed landing gear	Wheel base
Shape	Flow shape	Boxy with flat edge	Linear	Aerodynamic
Day light opening	Traditional front windshield, side opening on door	Traditional front windshield, side glass door	Complete glass windshield	Complete glass windshield
Door Type	Butterfly door	NA	Butterfly one side hinged	NA
Colour	White and Black	Silver Grey	Slate metallic grey	White, Red & Black
Surface type	Rounder and merging	Angled and flat	Edgy and sharp	Rounder and narrow
Edge type	Curvy	Straight with rounding	Mix of straight and curves	Subtle curves

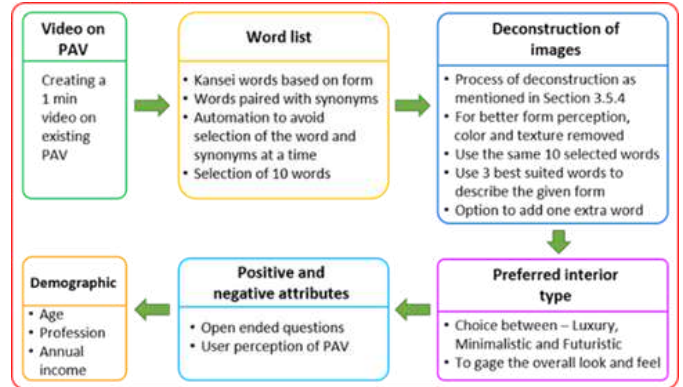

Figure 31 : Design Format Analysis & Form survey



Figure 32: Key areas for users' survey

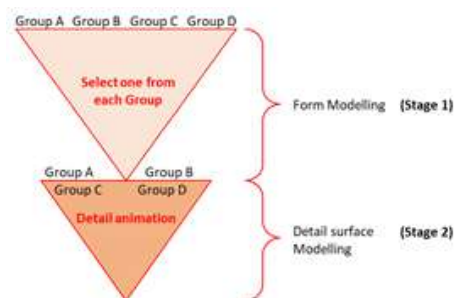

Figure 33: Process of creating artefacts

These twenty-eight scaled-form models were created based on these parameters and following practice-based research methodology. To conclude, here are a few images of the model-making process.

# Research Diary

These twenty-eight models were displayed in an exhibition inaugurated by our honourable director Prof B S Murty, on Jun 24, 2022. The show was open for four days and was visited by students of IITH, faculties, designers from Hyundai, school kids from DAV Public school IITH campus and many more.



# Students' Diary

## My Smart Mobility Journey

Mr H N Srikanth

MTech (Smart Mobility)

KID: 20220210



On one fine morning in February 2022, around 6:30 am, I got a call from one of the postdocs in my lab. I was informed to direct the truck driver to our lab and unload the Golf cart vehicle. Five months later, in June, the Golf cart vehicle is doing test runs autonomously on the roads of IIT Hyderabad, making itself ready to give a ride to the officials from the Department of Science and Technology (DST). Being enthusiastic about science and research, I started my Electrical Engineering degree in 2015. I completely engrossed myself in the world of electronics and parallelly worked on a research project. The positive response to this research project raised my confidence to pursue higher education in the happening fields. Apart from Electrical, I had gained knowledge and some hands-on experience in the robotics domain because my close friends used to run a robotics club at our college. I used to closely follow the latest works of companies like ABB and TESLA, which are sovereigns in the field of my interest. After clearing the GATE exam with a decent score in 2021, I looked at different specializations to pursue Masters at IITs. Like all other students, I also got stupefied with many questions in the back of my head. Besides other options, I got Smart Mobility from IIT Hyderabad in the fifth round. Looking at the department curriculum and good praises from seniors, I accepted the offer and have been one of those 19 students who formed the second batch of Smart Mobility.

COVID-19 pandemic relinquished my dreams about experiencing days at IITH. Unfortunately, my first semester courses happened online, but over time I slowly dwelled in the world of Autonomous vehicles, which seem fictitious until today. Around October, I was asked to join a team led by postdoc Dr Santhosh. This team works on the IITH and Suzuki collaboration of the Level4 Autonomous vehicle project. I was assigned to develop an algorithm for Pothole detection in Indian scenarios.

I felt fortunate for such an offer but was baffled at the same time that I had no experience in Deep learning projects before. After accurate readings and support from my friends, I ran my first Deep learning algorithm, which detected potholes. Thanks to the Open Source Projects on the internet and the invaluable documentation available, which is incompatible with the notion of the solitary genius. Completing courses like Machine learning, Random variables, Autonomous Navigation, and IoT laid the foundation for understanding the field of Autonomous vehicles. While exploring the university campus in the first weeks of December.

I came across TIHAN, which is getting ready to serve as a testing facility for Autonomous Vehicles and Drones. TIHAN was the first of its kind facility in India and had a hangar spread over almost 9500 square feet.

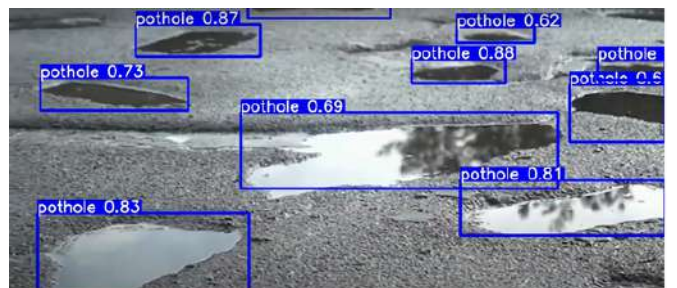

Besides the hangar, the testbed includes test tracks, Smart poles, Environment emulators for rainfall, SIL, HIL, MIL, VIL control centres, Drone runways, Anti-drone detection systems, & sophisticated labs. It seems to be nothing less than a facility that an Autonomous car enthusiast can dream of. From January 2022, I engaged myself in predominant courses such as Deep Learning and Visual Computing, which revealed to me the perception view of an Autonomous vehicle. During this time, working on different models from FRCNN to Swin Transformers on Autonomous applications with the support of many AI enthusiasts such as Dr Sumohana has escalated my curiosity in this field.

Concomitantly, I was asked to join a team meant to work on the Drive by wire technology and Golf cart vehicle Navigation. Thanks to the TIHAN project director and my faculty advisor Prof Rajalaxmi for assigning me to this diligent team. We were designated to work on Automotive grade sensors, mighty GPU boards, and high-end actuators at the Connected and Autonomous vehicles lab (CAV). In this lab, I met Dr Akshay, an erudite personality with a comprehensive knowledge of different fields. I should not miss mentioning Suneel, one of my seniors who shared a plethora of knowledge in the Autonomous domain with me.

In addition to this, I worked on an Autonomous bicycle. These urban mobility projects were showcased in front of distinguished personalities on the Inaugural day of TIHAN, i.e., the 4th of July.

# Students' Diary

When my second semester was about to end, we were informed about the one-month visit of Prof Srikanth Saripalli (Director of CANVASS lab at Texas A&M). Fortunately, he also took the Sensing and Planning for Autonomous vehicles course during this period. All his lectures were thought-provoking and put all my understanding of Autonomous vehicles in proper perspective. Personal interactions with him elucidated the path I should take to excel in this field. Working with people who own startups, making cool stuff to work for the first time, meeting people from different fields, fenced in with Autonomous vehicles. I could not have asked more for my 20s.



## Students' Diary

**A great experience that drastically enhanced my life.**

**Suneel Atmakuri**  
MTech (Smart Mobility)

**KID: 20220211**

Being one of the first students to join the pioneer batch of India's first Master's program in the domain of Autonomous Vehicles brought me closer to fulfilling my childhood passion for working with automobiles, which became even more exciting. I chose Mechanical Engineering as my Bachelor's degree at IIT Dharwad from 2016 to 2020 and investigated every nook and cranny of automobiles. I decided to pursue a career in the automotive industry after working with Volvo cars in 2017 and interacting with numerous industry professionals.

Along with my primary interest, I am constantly researching new technologies and advancements. Had worked on numerous projects in the Robotics domain using IoT and Cloud. Machine learning was another topic that piqued my interest while working on research projects at IIT Bombay.

The COVID-19 Pandemic affected us all in different ways. My seat in the Masters of Automotive Engineering program at RWTH Aachen, Germany, was declined because they did not accept international students, and my fallback job offer was also revoked. When exploring alternatives, this new Smart Mobility program at IIT Hyderabad appeared like a godsend. This was an obvious move where I could combine all of my passions into one large venture and participate in this exciting initiative. My first interaction with our professors was during my interview selection process. The encounter sparked my curiosity about working here. Everything had to be built from scratch. It was an excellent opportunity to display my enthusiasm. Had done various courses like Autonomous Navigation, Machine Learning, Introduction to UAVs, Computer Vision, Intelligent Transportation Systems, Sustainable Energy, etc. Dr Ashok Kumar Pandey's Vehicle Dynamics class is one of my favourites. I chose to work under him for my Thesis because he worked in one of my favourite fields. He was the one who encouraged me to pursue my passion for ground vehicles, both personally and professionally.



Along with an impressive academic record, I was offered an internship at Mercedes-Benz R&D in the Autonomous Driving field, where I not only gained hands-on experience with the technologies' real-world application but also built safety frameworks for several subsystems in AD and ADAS. As part of innovation developmental milestones, I also created features for Mercedes' infotainment system.

Thanks to Dr Rajalakshmi, TiHAN's Project Director, and my Faculty Advisor, for her unwavering commitment to seeing TiHAN expand at an exceedingly quick speed that was often difficult to keep up with. During my time at TiHAN, I was appointed as the overall MTech representative, responsible for the coordination and organization of not just key research programs and clusters but also major events. Thanks to all of my Smart Mobility friends and colleagues who believed in me and without whose help I would not have been able to succeed in this position.



# Students' Diary

Thanks to DST for sponsoring this NMICPS project to establish a technological hub for autonomous navigation, which allowed us to do not only theoretical research but also hardware implementation. In such a short period of time, the TiHAN testbed was completed at a rapid pace. It is a first-of-its-kind, cutting-edge Testbed for Autonomous Navigation (Aerial/Terrestrial). Proving Grounds, Test tracks, Mechanical integration facilities such as Hangers, Ground control stations, Anti-drone detection systems, State of the art Simulation tools (SIL, MIL, HIL, VIL), Test tracks/circuits, Road Infra - Smart Poles, Intersections, Environment Emulators such as Rainfall Simulators, V2X Communications, Drone Runways & Landing area, Control Test centers are among the facilities.

I would be eternally grateful to my TiHAN mentor, Dr Akshay Ramesh Jadhav, Post Doctorate Fellow, Department of Electrical Engineering, for his vast technical knowledge in almost everything while also consistently guiding me in newer methodologies and technologies. In January 2022, I began working under him. I was a member of the Connected and Autonomous Vehicles (CAV) lab, where I worked on practically every area of Self Driving Vehicles, from sensing, localization, and path planning, through actuation, control, and safety.

I was involved in the development of an autonomous bicycle, which is the need of the hour for campuses like IIT Hyderabad as well as for Indian conditions in general. The electric bicycle can now drive itself to and from the user, allowing for last-mile connectivity and encouraging ride-sharing. An application was created to summon and track the bicycle to the user's position in real-time.

Next, I worked on establishing basic navigation algorithms using GPS and a camera on a smaller car in the testbed. There was a lot of optimisation done here. I was able to work on industry-grade equipment and gear that I would not have been able to do otherwise. It was a fantastic research experience in the field of autonomous driving, and it is the reason I am where I am now.

My main objective was to create self-driving campus transportation. In this project, I was engaged in developing Autonomous Shuttles from scratch. We modified a brand new electric 14-seater shuttle to follow commands. Drive-by-wire is what we call it. After command-based testing of various scenarios, we began integrating communication and inter-program divulgence protocols. An in-vehicle controller was equipped to accommodate low-level actuations, as well as numerous sensors such as GPS, IMU, Camera, and LIDAR for various algorithms responsible for making vehicle decisions. A Navigation technique was constructed using numerous of these algorithms to move the vehicle given the destination, just like a human-driven, but without a driver. With increased robustness, we expect such autonomous vehicles to gradually replace the regular shuttle service on IITH's major routes to transport fraternity members in and around campus.

Finally, I want to thank all of my project colleagues and staff for their assistance, whether it was with their codes and algorithms through changing batteries in vehicles. I am currently working as a Senior Engineer in Autonomous Driving at Robert Bosch. I would undoubtedly miss IITH and TiHAN, which were such an important part of my life. What I assumed was a placeholder turned out to be a great experience that drastically enhanced my life.

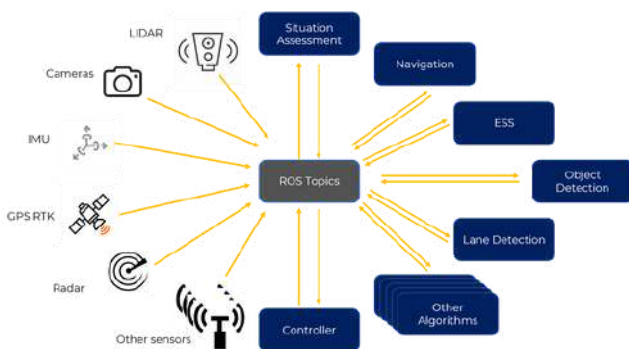



# Alumni's Diary

## Design and Development of Autonomous UAV Configuration for Detection and Tracking of Beyond Visual Range Objects

Dr Chandrakanth V

PhD (2022), Department of Electrical Engineering  
Scientist DRDO, Hyderabad

KID: 20220212

### Introduction:

The past decade has all been about IoT and AI. Though both the concepts have a very different scope of work, researchers have been trying to unify both technologies to realize Smart systems. 'Smart' has been the new sensation of the past decade. We have been working towards, if I may say, 'Smartifying', everything in our life. Though the concepts are not new, the applications are quite novel. Using a simple wifi chip (ESP 8266 etc.) in every electronic device, we have converged our entire electronic ecosystem into an App on our mobile. With IoT, we achieved control; with AI, we automated it and lost control.

### Autonomous Aerial System (UAV) Design:

In this report, I will focus on smart mobility. We can conservatively estimate that every human spends 1-2 hrs per day travelling. From a global perspective, this translates to millions of man-hours per day which can be put to better use. This thought led to the idea of autonomous driving systems (ADAS). The simplest form of automatic driving we are familiar with is the auto-pilot mode used in air-crafts and cruise control mode in cars. These technologies work in a very limited set of environmental and vehicular dynamics. In both cases, the driver has to be constantly vigilant and take control of manual operation if the underlying scenarios in which the auto-pilot or cruise control are engaged have changed. For example, change in weather causes signal disruption in air-craft transponders or an increase in traffic on highways where the cruise control can no longer maintain the speed. So these methods can be considered semi-autonomous systems.

With the advent of AI, a new era of fully autonomous systems evolved where manual operations are drastically minimized. For example, the new XUV 700 has ADAS, which automatically slows down and halts if there is any obstruction in the path, though it is set on cruise control mode. This is a significant achievement obtained by the fusion of a multitude of sensors onboard the vehicle.

Smart mobility encompasses various elements of technology and mobility. It is a novel approach towards the design and development of the transportation infrastructure used in daily life. Besides using traditional motor vehicles, electric vehicles, and public transportation systems, it also encompasses new modes of transportation like on-demand ride-sharing services (Uber and Lyft) and car-sharing programs. Changes in consumer behaviour coupled with the rise of completely new mobility options are rapidly changing how people get around. Concerns around pollution, traffic congestion, loss of productivity and (of course) money have made this idea gain traction in recent years.

Smart mobility can be broadly divided into the following subsets:

- Transportation Infrastructure facilitating smart mobility
- Ground and air-based traffic control algorithms
- Multi-sensor fusion on edge systems
- Information Fusion at the central node
- Autonomous systems

Each module mentioned above in itself is a huge area of research. We limit our discussion to the autonomous driving part of the smart mobility ecosystem.

The Society of Automotive Engineers (SAE) currently defines six levels of driving automation ranging from Level 0 (fully manual) to Level 5 (fully autonomous). These levels have been adopted by the U.S. Department of Transportation.

Autonomous systems are not new, but the present-day systems are far more advanced than the traditional auto-pilot systems etc. The breakthrough in machine learning algorithms on object detection, classification and localization, and natural language processing made huge strides towards the success of autonomous systems. The evolution of autonomous driving systems can be summarized as follows:

- Class 1: No Automation-The system operates under complete manual control
- Class 2: Basic Automation-The system offers basic automation like cruise control
- Class 3: Partial Automation-ADAS systems currently being used fall under this criteria
- Class 4: Conditional Automation-The system is capable of monitoring environmental conditions and performing most driving tasks, but manual supervision is required
- Class 5: High Automation-The system performs all driving tasks under specific circumstances with Geo-fencing constraints
- Class 6: Full Automation-The vehicle performs all driving tasks under all conditions with zero human interaction

Present-day systems fall in the Class 3 category inching towards Class 4. However, Class 5 systems are still under active research. They have a new set of problems to address before the system reaches full automation.

During my PhD at Indian Institute of Technology Hyderabad, I worked on aerial autonomous systems. The future of transportation will be multi-tier commuting systems working in parallel and in perfect sync. Autonomous aerial travel is still very nascent compared to ground vehicles but is a highly researched area around the world. To start with, we narrowed the problem definition to autonomously detecting and tracking targets beyond visual range without any manual intervention. The proposed problem has numerous applications in the e-commerce industry, disaster relief operations in inaccessible terrains, medical transport etc.

We designed and developed a custom UAV architecture integrated with custom hardware on-board the UAV for autonomous object homing beyond visual range. Fig. 2 shows the proposed architecture. The proposed solution is based on deep learning. The system is designed to automatically take off and fly in known bearings (i.e. initial conditions). After clearing visual space, the algorithm on board the Jetson Nano Board enters the search phase, continuously looking for the object of interest. Once the object is detected, the algorithm is set to track mode, which continuously manoeuvres the UAV towards the object. When the UAV is in the pre-defined range of the object, the terminal mode is activated, and the UAV lands before the object of interest and delivers the package.



# Alumni's Diary

The autonomous control is field tested with pre-defined control commands generated at random instants, and the UAV successfully followed the commands from the launch point and back. The work is published in Springer Journal of Real-Time Image Processing titled "UAV-based autonomous detection and tracking of beyond visual range (BVR) non-stationary targets using deep learning". A patent is applied to the architecture, which is published in the open domain. For further details, I encourage the interested reader to study the paper available in the Springer library.

## Conclusion:

The presented solution is part of a smart mobility ecosystem, which encompasses a wide range of alternative modes of transportation, including traditional gas and electric vehicles, bike and scooter share programs, autonomous ground and aerial vehicles, rail lines etc. The systems that handle benign conditions are already developed and field tested. However, the development of fully automated systems in complex environments is still an active area of research. To the best of our knowledge, the work presented is the first step toward autonomous aerial systems.

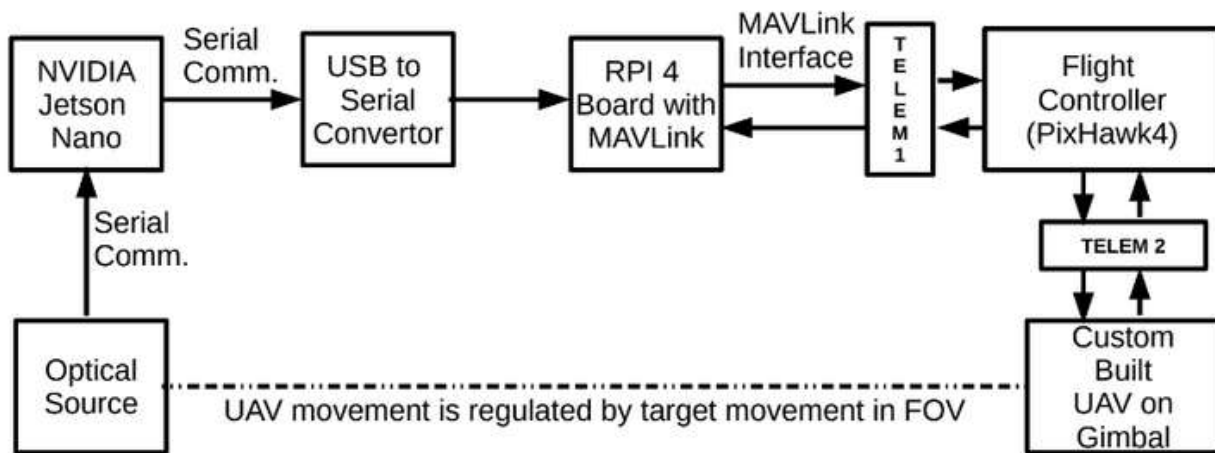

Figure 34: The proposed architecture for real time implementation

## My Life @IIT Hyderabad:

Hi, I am Chandrakanth, an external PhD student in the Electrical Engg department. I am a scientist working in DRDO. I love music, reading books (currently reading Sapiens by Yuval Noah Harari, it's awesome), watching movies and cooking. I hope to direct a movie. (It's a secret, so don't tell anyone )

I am a Hyderabadi. Born and brought up in this beautiful city. I did my Master's from IIT Bombay and was planning to do my PhD there. But since, since I am a working professional I had to choose a place where can commute regularly and interact with my advisor and fellow students. My Master's Thesis Supervisor suggested me to join IIT Hyderabad, which is progressing rapidly among second Tier IITs and has a wonderful campus and excellent faculty. I am glad I joined IIT Hyderabad, where I could find my mentor, who is an amazing gentleman both personally and academically. Its been a privilege to work with him, which I will cherish my entire life.

Learning new things is my passion. So, I have always been pushing my boundaries, taking new subjects and topics which helped me broaden my knowledge. So I would say all the subjects I took, I enjoyed learning them, and if I have to pick one it would be Machine Learning based Image processing.

Yes, definitely. With the knowledge I gained at IITH, I proposed the very first autonomous UAV design, which is patented.

The best Moments @IITH would be the discussion and presentations we had in our lab. For my first semester, I stayed in the hostel to finish my coursework. I had some fond memories with my roommate and neighbours.

To existing folk, I would like to say that enjoy every moment to the fullest. Take part in as many activities as you can. Find your passion. Don't just be a book bug; broaden your horizon. Make good friends and good memories, and make the best of the IITH experience.

IITH has amazing faculty. The research done is at par with first-tier IITs. The only drawback is there is no proper relationship between management and students. A common portal which everyone can access and a dedicated team to solve the problems posed by the students.

I would request IITH management to encourage, motivate and help the students as they are the future of this country.

You can always reach me at [chandrav.iitb@gmail.com](mailto:chandrav.iitb@gmail.com).

To conclude here, I would like to say that **"Never Regret. Never be afraid to try new things. These are the most precious days of your life; make memories which you will cherish forever. Time and health are the only variables that really matters in life. so don't waste time and stay healthy in mind and body."**



# Incubatee's Diary

## Activities by iTIC Incubator @ IITH

Divya Bansal, Executive - Digital Marketing (R)

Keyur Punjani, Manager - Programs (L)

i-TIC Incubator

KID: 20220213

### Startup Annual Meet

iTIC hosted a closed-door startup annual meet for networking with entrepreneurs associated with iTIC ecosystem. The event also saw Coffee Table Book launch, showcasing and celebrating all the startups supported by iTIC.



### Fabrication Factory Series:

With the aim to provide hands-on skills to early-stage startup founders and lab operators, iTIC organized a 3-week long Fabrication Series that covers fundamentals and basic operations of tools and equipment.



### Innovation Accelerator

iTIC and TiHAN organized a 4-day Innovation Accelerator to support researchers turn their research ideas into startups. The Accelerator was conducted in Hybrid mode with a few sessions conducted virtually and the rest of them physically.



### iDEX Roadshow:

iTIC and t-hub organized a roadshow to share insights on iDEX DISC 6 challenges and PRIME challenges. iDEX is a program to support Defense related startups/MSMEs by providing them access to financial aid, mentoring, and other required support to solve some of the most critical problems of defense.



# Incubatee's Diary

## iLAB Inauguration

Shri D K Mohanty, Director (Production), NMDC Limited, inaugurated iLAB in the esteemed presence of Prof. B S Murty, Director, IIT Hyderabad. iLAB is a state-of-the-art prototyping lab under iTIC Incubator at IIT Hyderabad, which consists of prototyping machines, design tools, computing systems, and XR equipment to build all types of prototypes



## TIP Building Inauguration

Shri. Dharmendra Pradhan, Hon'ble Minister of Education, Govt. of India, inaugurated the TIP facility in the august presence of Dr. BVR Mohan Reddy, Chairman, BoG, IITH, and Prof B S Murty, Director, IITH. Technology Innovation Park will host incubators at IIT Hyderabad, creating a supportive and nourishing environment for budding entrepreneurs in the technology field. TIP is built using the fund support of JICA, and the University of Tokyo is its concept designer.



## Startup Stories

### Persist Energy

Persist Energy is an IIT Hyderabad incubated electric mobility startup laying the foundation for mass adoption of electric vehicles for MSMEs and micro-entrepreneurs. The Hyderabad-based startup is dedicated to building its products with an emphasis on "Atmanirbhar Bharat" and a far-reaching focus on empowering grass root level commercial logistics with affordable and intelligent mobility solutions.

The company was founded by three enthusiastic problem solvers, Bharavi, Harshin and Ashish, in 2019. The founders have together covered the bases necessary to take such a startup off the ground, with Bharavi being a business model enthusiast with a masters in entrepreneurship and experience working for Amazon Robotics in Massachusetts, Harshin being an automobile savvy automobile engineer with experience in SAE student teams and Mahindra & Mahindra and Ashish, a DIY savvy software engineer with experience working for Meeru Cabs and also IoT systems for Dubai Urban Transport.

Their penchant for answering the question, "what does it take for electric vehicles to be adopted on a large scale by developing nations?" led them on a journey that included extensive exploration of the market in terms of mobility options available and use cases for electric vehicles. They believe they have found a very promising use case: the MSMEs and micro-entrepreneurs who support the majority of retail purchases in our nation. The founders point out that an average urban salaried individual who can purchase the above Rs 1,50,000 vehicles in the market and travels less than 50kms daily don't really care for electric vehicles.

Electric vehicles are but a novelty product to them. Only a small niche of this customer base that is environmentally conscious will adopt electric vehicles. But the small business owners who travel upwards of 80kms a day, and spend more than Rs 4000 monthly on fuel can really benefit from the cost-effective nature of electric vehicles. This customer will strongly and rapidly adopt electric vehicles if provided an option that matches their requirements and spending power. The founders also realized that while vehicles had to be designed for their requirements, the problem of the high initial cost of acquisition of electric vehicles and consumable batteries also has to be dealt with.

They came up with innovative business models based on flexible battery ownership that can reduce the initial acquisition cost by more than 30% compared to options in electric vehicles. The kicker is that this model allows them to potentially price their product lower than the currently popular IC engine option.

# Incubatee's Diary

They bootstrapped and started working from a terrace to build an electric mobility ecosystem with a smart, rugged two-wheeler at the epicentre, tailor-made for the entrepreneurs and business owners looking to power and scale their businesses with affordable and scalable transportation. They worked through the pandemic and raised grants in cash and kind from Northeastern University, Boston, Autodesk, and Amazon. They built their prototypes of a rugged electric two-wheeler and tested it with their customers. They have received an overwhelmingly positive response and some valuable feedback. In the later part of 2021, they also got selected into the winter cohort of the Mass Challenge venture accelerator based in Boston. They achieved this after competing against 3000 startups from 61 countries in multiple rounds. After a cohort period of four months, they managed to make a place for themselves in the top 20 startups out of a cohort of 229 startups and were awarded a gold award grant of \$25,000. They were the only startup outside the USA to get this award from that cohort.

As the team was growing, they were looking forward to incubation. The founders say that out of the options available, IIT Hyderabad provided the best environment required for their growth. They are currently incubated under the Advanced Incubation Program under iTIC Incubator at IIT Hyderabad. They are currently gearing up for the launch of their vehicle in march 2023. They have integrated well with Telangana's local markets, and many of these businessmen are awaiting the launch of their vehicles. Along with the vehicle, they are also debuting their charging systems explicitly built to be implemented for their customer base but also can service other electric vehicles.

The founders believe that the vehicle is just the first step. They have many innovative solutions such as open source app aggregating of the vendors using their vehicles. They wish to support the growing Indian business owner not just with a vehicle, but a business vehicle that supports their business in more than just transportation.



### IIT-Hyderabad takes early lead in 6G tech

A three-fold improvement over state-of-art 5G massive MIMO technology; R&D dean

SPECIAL CORRESPONDENT HYDERABAD

The Indian Institute of Technology-Hyderabad (IIT-H) has announced a demonstration of extreme Massive MIMO (Multiple-Input Multiple-Output), a key technology that is being considered for 5G advanced and 6G deployments.

"Using multiple antennas at the base station, massive MIMO increases the coverage and capacity of cellular networks. This technology

has become mainstream and is now an integral part of 5G. Extreme massive MIMO refers to next-generation technology that uses very large antenna arrays. IIT-H developed an experimental research prototype with the aim to discover achievable performance limits," said dean (R7D) Kiran Kuchi.

The first set of pilots conducted using 192 antennas and 48 radio frequency chains showed that up to 24-36 users could be served in

the same spectrum. This is a three-fold improvement over the state-of-art 5G massive MIMO technology, designed to support 12 simultaneous users, he added.

For cellular operators and users, this technology offers immense benefits - cell phone users will experience high-quality voice and video delivery in crowded areas like airports, malls, and railway stations.

"Cellular operators will be

able to offer broadband wireless internet in rural households, dynamic steering of the cell site beams to reduce coverage holes in urban as well as rural areas," explained Mr Kuchi.

Spectrum is a scarce natural resource, and in countries like India, with a large population and limited wireline infrastructure, the demand for spectrum will continue to be very high, pointed out IIT-H director B.S. Murty.



### బహిష్కారంలోని టీహెచ్ సారథిగా శ్రీకాంత్



కంది, ఏప్రిల్ 21: సంగారెడ్డి జిల్లా కంది పంది బహిష్కారంలోని టీహెచ్ (బిక్నాలజీ ఇన్స్టిట్యూట్ హబ్ ఆఫ్ ఆటానమస్) సారథిగా ఆమెరికాలోని బిక్నాన్ యూనివర్సిటీలో డిప్యూటీ ప్రొఫెసర్ అయిన మెకానికల్ ఇంజనీరింగ్లో ప్రొఫెసర్ గా పనిచేస్తున్న శ్రీకాంత్ సరిపర్తి మంగవారిని నియమితులయ్యారు. గ్రౌండ్ అండ్ ఏరియల్ వెహికల్స్ కోసం కనెక్టివ్ ఆటానమీ, సెన్సార్ల అప్లికేషన్ రంగంలో శ్రీకాంత్ చేసిన విశేష కృషికి గౌరవార్థంగా టీహెచ్ సారథిగా నియమించారు. ఆయన బహిష్కారంలోని ఆటానమస్ నావిగేషన్ సిస్టమ్లో సారథిగా 3 సంవత్సరాల పాటు కొనసాగుతారని బహిష్కార అధికారులు వెల్లడించారు. ఈ సందర్భంగా టీహెచ్ ప్రాజెక్ట్ డైరెక్టర్ పి.రాజులక్ష్మి మాట్లాడుతూ ప్రొఫెసర్ శ్రీకాంత్ నైపుణ్యం తదుపరి సాంకేతిక అభివృద్ధికి తోడ్పడుతుందన్నారు. బహిష్కారంలో సాంకేతికపరమైన చర్యలను అగ్రణీకా నిరందించిన, బహిష్కార యొక్క ప్రత్యేకమైన ఇన్స్టిట్యూట్ కార్యక్రమాల్లో టీహెచ్ ఒకటని బహిష్కార డైరెక్టర్ టి.వి. మూర్తి పేర్కొన్నారు.

### Research in India will make technologies affordable, says Kris Gopalakrishnan

IIT Hyderabad has celebrated its 14th Foundation Day on April 09, 2022, in the Hybrid Mode and telecast the proceeding live on YouTube. Senapathy "Kris" Gopalakrishnan has graced the occasion with his kind presence as Chief Guest. Dr BVR Mohan Reddy, Chairman BoG, IITH as Guest of Honor amidst Prof B S Murty Director, IITH, Deans, Heads of the Departments, Faculty, Staff & Students.



IITH has been awarded four ISO Process Excellence on the Occasion by HYM International Certification, a third-Party Quality Assurance Certification Body accredited by ASCB(UK) for Education Services, Greenery & Environmental Promotional Activities, Energy Saving Practices, and Data Security Services. The occasion became more momentous with the announcement of the Faculty Teaching, Faculty Research, Staff Service & Student Aca-

ademic & Research Excellence Awards. More than 160 achievers have been honored by the dignitaries for their untiring & persistent contribution to the institution's growth.

Delivering the welcome address, Prof B S Murty, Director, IITH, said, "Happy to see your faces without the mask after two years of virtual foundation days. Dream Big, and let your dreams be as colorful as possible. Follow your passion, the success

will follow. Excellence should be our motto, nothing less than that, and I am sure you all will strive towards it".

Applauding Kris for his contribution to the upliftment of research & entrepreneurship in the country, Dr BVR Mohan Reddy, BoG said, "As an institute like IIT, we should think about Aatma Nirbhar Bharat and work towards Job Creation. As humankind, what we need to move forward is science and technology,

and institutes like IITHs are truly at this intersection. What more we need to do is to see how to give back to society in terms of monetization, research, & technology.

Praising IITH for the cutting-edge research & talking about why brain research is his area of interest, Kris Gopalakrishnan said, "It is interesting to understand how brain development happens from the fetal stage to the aging stage. Institutes like IITHs being multidisciplinary are ideal for such critical research. World-class research is possible in India, can be done in India, and must be done in India. It is important as India becomes a developed economy."

The event proceeded with the announcement of the excellence award by the Deputy Registrar (Academics), Dean (Academics), Dean (Faculty) & Dean (Admin), followed by the vote of thanks by the Dean (Students) & National Anthem.

### Cancer Screening on Wheels launched

HANS NEWS SERVICE HYDERABAD

MALLA Reddy Narayana Hospitals (MRNH), Suraram, Jeedimetla, Hyderabad initiated the Cancer Screening programme in association with IIT Hyderabad (IITH).



The programme was launched on Wednesday by Haragopal, Director of Finance, MRNH, and Prof B S Murty, Director, IITH, with the Screening of more than 100 Contract Workers at IITH by the MRNH Team at Primary Health Centre (PHC), IITH. The Cancer screening drive is done on a large Eicher bus fully loaded with all screening equipment. The Cancer screening coach is supported by the Rotary Club of Ameerpet, Operated and managed by the MRNH Team.

The bus has facilities like Doctor Consulting Room, Mammography, Colposcopy, X-ray, and reporting room. It also provides television to display the preventive videos and has a separate washroom inbuilt. MRNH has developed an exclusive, well-trained team to drive the Cancer Screening programme on Wheels.

Thanking Dr Bhadra Reddy, Chairman, and Haragopal, Director Finance, MRNH, for this generous gesture, Prof B S Murty said, "Through this collaboration with MRNH, we would like to take the Cancer Screening to the doorsteps of villagers.

According to real runs being up to

### IIT-H launches CfHE Vagbhata chair professorship

The Indian Institute of Technology (IIT), Hyderabad in collaboration with Rajesh Mashruwala, TIBCO Software executive vice president and co-founder of CfHE, announced the Center for Healthcare Entrepreneurship (CfHE) Vagbhata chair professorship in the area of medical devices and diagnostics to contribute toward the institute's work in this area.



According to a statement from IIT Hyderabad, Mashruwala intends to work on healthcare ideas such as non-invasive diagnostics, point of care devices, and clinical trials of portable devices to address the last mile in healthcare delivery to rural and interior parts of India in medical devices

and diagnostics. With a vision for Aatma Nirbhar Bharat and Make in India, the Department of Biomedical Engineering, IIT Hyderabad undertakes focused programmes in medical devices, development of human re-

sources, and start-up promotion for indigenous development of medical devices and innovations.

"The Center of Excellence, established in partnership with the Medical Devices Mission Secretariat, ICMR, has enabled IITH

to be one of the Hubs for technological Excellence in Medical Devices in India," the IIT Hyderabad said. Prof B S Murty, Director, IIT Hyderabad, said, "We envision IITH to be one of the choicest destinations for faculty and students who would like to pursue their career goals.

This Chair Professorship will be a golden opportunity for bringing eminent National and International faculty and industry leaders to collaborate with the Department of Biomedical Engineering at IITH with a focused vision to strengthen this area, develop new courses and programmes, and attract new faculty, visiting faculty, international grants, etc."

THE TIMES OF INDIA

# IIT Hyderabad technique to gift new lease of life to aging bridges, buildings

In good news for the construction and infrastructure sector, researchers at the Indian Institute of Technology Hyderabad (IITH) have developed a hybrid fiber-reinforced polymer (FRP) solution that can extend the life of structures that have deteriorated due to factors like aging and corrosion. The technique offers a cost-effective solution for increasing the longevity of old and aging structures like railway bridges, and multi-storey buildings. Prof S Suriya Prakash's CASTCON Lab at the IITH has developed the innovative hybrid FRP strengthening technique for improving strength and ductility under different loading combinations. The hybrid FRP strengthening technique is a very efficient solution to improve the strength and ductility for the real scale structural elements of bridges and buildings. We have extensively carried out experiments to understand the size, shape, and slenderness effect on the behaviour of hybrid FRP strengthened elements for various loading scenarios. We are currently developing efficient analytical models for developing the design guidelines that practicing engineers could readily use." Prof Prakash said. Instead of having to destroy aging structures and build anew, using the

In recent times, the civil engineering industry has gradually accepted FRP (fiber-reinforced polymer) composites to repair and rehabilitate concrete structures. FRP strengthening has numerous advantages over conventional strengthening methods such as concrete and steel jacketing due to its lesser weight to strength ratio, corrosive resistance, easy installation, and higher durability.



The hybrid FRP strengthening technique is a very efficient solution to improve the strength and ductility for the real scale structural elements of bridges and buildings. We have extensively carried out experiments to understand the size, shape, and slenderness effect on the behaviour of hybrid FRP strengthened elements for various loading scenarios. We are currently developing efficient analytical models for developing the design guidelines that practicing engineers could readily use. - Prof Prakash

hybrid FRP material, government and private sector infrastructure players can easily reinforce bridges and offshore structures that are reaching the end of their lifespan.

In recent times, the civil engineering industry has gradually accepted FRP (fiber-reinforced polymer) composites to repair and rehabilitate concrete structures. FRP strengthening has numerous

advantages over conventional strengthening methods such as concrete and steel jacketing due to its lesser weight to strength ratio, corrosive resistance, easy installation, and



higher durability, an IITH statement noted. Congratulating the research team on this innovative hybrid FRP strengthening solution, Prof B Murty, Director, IITH, added: "The preservation and extension of service life of the existing civil infrastructure are essential for fuelling our country's economic growth. At the same time, this innovation developed by Prof Suriya and his team leads to optimum utilization of the strengthening materials. It is cost-effective for increasing the longevity of civil infrastructure."

ABN ఆంధ్రజ్యోతి



ఆన్ లైన్ లో రాజేష్ ముఖ్యమంత్రి ప్రకటిస్తున్న వీడియో మాట్లాడుతున్నారా

## వజ్రహాచారీని సీఎఫ్ హెచ్ కు మెడికల్ డయాగ్నోస్టిక్ చైర్ ప్రొఫెసర్ గా రాజేష్ ముఖ్యమంత్రి

కంది, మే 4: నంగంపల్లి జిల్లా కంది పరిధిలోని వజ్రహాచారీలో ఉన్న సీఎఫ్ హెచ్ (సెంటర్ ఫర్ హెల్త్ కేర్ అండ్ ప్రెవెన్షన్) మెడికల్ అండ్ డయాగ్నోస్టిక్ విభాగంలోని చైర్ ప్రొఫెసర్ గా డాక్టర్ సోమేశ్వర్ ఐచ్ఛ సంస్థ వ్యవస్థాపకుడు రాజేష్ ముఖ్యమంత్రి నియమితులయ్యారు. ఈ మేరకు మద్యం ఆఫీస్ వేదికగా వజ్రహాచారీ జైర్ కేంద్ర వీడియో మాట్లాడుతున్న ముఖ్యమంత్రి రాజేష్ ముఖ్యమంత్రి ప్రకటించారు. రాజేష్ ముఖ్యమంత్రి వైద్య పరిశ్రమ, స్పెషిలిటీ అభివృద్ధి కోసం సీఎఫ్ హెచ్ ని స్థాపించి బాగా సామాజిక సేవలందించారు. ఆయనకు ఇండియన్ మెడికల్ అండ్ హెల్త్ టెక్నాలజీ అసోసియేషన్ అనుబంధం ఉంది. సీఎఫ్ హెచ్ కు వైద్య పరిశ్రమ అభివృద్ధిలో, ఆరోగ్య సంరక్షణలో కీలకమైన పాత్రాల్లో ఒకటి. అంతేకాక ఆర్థిక నిర్బంధం లేకుండా, మేకప్ ఇన్ ఫ్రాస్ట్రక్చర్ కోసం వజ్రహాచారీని నియమితులం చేసింది. రోగి విభాగం వైద్య పరిశ్రమ, మానవ వనరుల అభివృద్ధిలో సమన్వయం పరచుకుంటున్న ఆర్థిక సంస్థలందరినీ చైర్ ప్రొఫెసర్ వీడియో మాట్లాడుతున్న ముఖ్యమంత్రి సీఎఫ్ హెచ్ కు మెడికల్ డయాగ్నోస్టిక్ చైర్ ప్రొఫెసర్ గా నియమితులం చేసింది. వీడియో మాట్లాడుతున్న ముఖ్యమంత్రి సీఎఫ్ హెచ్ కు మెడికల్ డయాగ్నోస్టిక్ చైర్ ప్రొఫెసర్ గా నియమితులం చేసింది. వీడియో మాట్లాడుతున్న ముఖ్యమంత్రి సీఎఫ్ హెచ్ కు మెడికల్ డయాగ్నోస్టిక్ చైర్ ప్రొఫెసర్ గా నియమితులం చేసింది.

### THE TIMES OF INDIA

Copyright © 2014 Bennett Coleman & Co. Ltd. All rights reserved

Tue, 10 May-22; Times Of India - Hyderabad; Size : 140 sq.cm.; Circulation:267065; Page : 3

## 9 deep-tech startups to grow with IIT-H incubator support

TIMES NEWS NETWORK

Hyderabad: The incubator at the IIT-Hyderabad has selected nine deep-tech startups from across India for their pre-incubation and incubation support programmes. A signing and on-boarding ceremony was organised to facilitate and give a boost to top-notch startups on Monday.

The IITH Incubator will be investing more than Rs 1.7 crore in deep-tech startups. Currently six of the nine startups have a ready prototype. These include Learn and Empower, which is working on building an accessible game-based learning platform for children with hearing loss; LigSure Systems, which is building a water purification system using hydrodynamic cavitation

### SUPPORT SYSTEM



- ADDITIONAL HELP
- ▶ Structured mentorship
  - ▶ Co-working space
  - ▶ Access to maker lab
  - ▶ Access to networking and events
  - ▶ Investor connects
  - ▶ Access to IIT-H infra

principle for greywater treatment; Milatronix, which is building automated feeding system for aqua farmers; Pranahita Biotronics is developing AI-powered low-cost testing kits for Covid and other viruses; Efficare is working on regenerative products for gums and periodontists treatments. IITH is also investing in three 'proof of concept' stage startups: Humus Biosys-

tems, which is working on water treatment using microbes and biomaterials; Rabo Systems, which is working on developing surgical assistive robots; and Sridevi Machinery which is working on building automated power weeder. Welcoming the startups onboard, BS Murty, director, IITH said, "The focus of IITH is on translating the innovations into technologies useful for humanity."

### मिलाप

Copyright 2014 Daily Hindi Milap. All rights reserved.

Sat, 28 May-22; Daily Milap - Hyderabad; Size : 12 sq.cm.; Circulation:44300; Page : 4

## संज्ञानात्मक विज्ञान पर आईआईटी हैदराबाद का वेबिनार 7 से

हैदराबाद, 27 मई- (मिलाप न्यूज़)

आईआईटी हैदराबाद द्वारा आगामी 7 से 9 जून तक संज्ञानात्मक विज्ञान में उपरते कक्षा पर वेबिनार का आयोजन किया जाएगा।

तीन दिवसीय वेबिनार में मनोविज्ञान, भाषा विज्ञान, दर्शन और कम्प्यूटर ग्राफिक्स के परस्पर पर चर्चा की जाएगी। इससे अज्ञात बहना वास्तु विज्ञान से एक संज्ञानात्मक संज्ञाना विज्ञान का अर्थ, व्याख्या का अर्थ, संज्ञानात्मक सिद्धांत में तार्किक योगदान एवं अन्य विषयों पर अपने विचार साझा करेंगे। मुख्य बहना के रूप में साउथ एशियन रिसर्च फोरम का आयोजन है। वेबिनार में हिस्सा लेने के लिए tinyurl.com/26jvdxav पर पंजीकरण निरालक है।

### DECCAN HERALD

Copyright 2014, The Printers (Mysore) Private Ltd.

Thu, 23 Jun-22; Deccan Herald - Bangalore; Size : 92 sq.cm.; Circulation:204182; Page : 9

## IIT Hyderabad opens heritage science & technology department

PRASAD NICHENAMETLA HYDERABAD, DHNS

The Indian Institute of Technology Hyderabad has opened a first of its kind Department of Heritage Science and Technology (HST), and is offering a new MTEch programme in the subject. The HST is established with the aim to unlock the latent val-

ue in Indian heritage assets by developing technology to help the fragmented segment to aggregate, modernise and scale. IIT professors said. The online course on Heritage Science and Technology would be offered with three specialisations—science & technology of Yoga, Indic language processing, and conservation and reconstruction of

heritage architecture. The new department was opened on the occasion of the International Yoga Day, on Tuesday, by Padma Bhushan Dr Vijay Bhaskar, best known as the father of India's PARAM series supercomputers. "Bringing heritage and science together to India's premier institutions is a small but giant step in Indian academics.

This shows the way to recreate the ancient Takshashilas and Nalandas in a contemporary form. Happy to note that IIT Hyderabad has taken the lead in this aspect," Dr Bhaskar said. MTEch course, beginning in August 2022, will be in online mode for two years, where the second year is for a thesis project with focus on either research or product development.

### ఇది... వజ్ర హాచారీ!



సాంస్కృతిక విరాసతిని అభివృద్ధి చేయడానికి మేము ప్రయత్నిస్తున్నాము. వజ్రహాచారీలో ఉన్న అనేక సంస్కృతిక వస్తువులు మరియు నిర్మాణాలు, వాటిని రక్షించే మరియు అభివృద్ధి చేయడానికి మేము ప్రయత్నిస్తున్నాము. వజ్రహాచారీలో ఉన్న అనేక సంస్కృతిక వస్తువులు మరియు నిర్మాణాలు, వాటిని రక్షించే మరియు అభివృద్ధి చేయడానికి మేము ప్రయత్నిస్తున్నాము. వజ్రహాచారీలో ఉన్న అనేక సంస్కృతిక వస్తువులు మరియు నిర్మాణాలు, వాటిని రక్షించే మరియు అభివృద్ధి చేయడానికి మేము ప్రయత్నిస్తున్నాము.

# IITH in News

Thu, 12 May-22; Namaste Telangana - Hyderabad; Size : 367 sq.cm.; Circulation:70387; Page : 3

## వాహనాలు మాట్లాడుకొంటాయ్!

- టెన్వీల్లో భద్రకా డిజిటల్ అభివృద్ధి చేసే ఐఐఐఐఐ వాహనాలకు, మారుతూ మోటార్స్
- ఫ్రాలోల్డ్ల వాహనాలలో ప్రయోగ వర్కేట్ అభివృద్ధి
- ఈ డిజిటల్ అభివృద్ధి వాహనాల సులభత
- అభివృద్ధి వర్కేట్లలో లోన్లు ప్రయోగించు అభివృద్ధి (సూపర్, డి.11 (డబ్ల్యు.కె.ఎం.ఎం.)) వాహనాలలో భద్రకా వాహనాలను అభివృద్ధి చేసి ఐఐఐఐఐ వాహనాలకు డిజిటల్ అభివృద్ధి చేసింది.



ఐఐఐఐఐ వాహనాలలో డిజిటల్ అభివృద్ధి చేసేందుకు అభివృద్ధి వర్కేట్లను అభివృద్ధి చేసేందుకు ఐఐఐఐఐ డి.11 (డబ్ల్యు.కె.ఎం.ఎం.ఎం.ఎం.) వాహనాలలో భద్రకా వాహనాలను అభివృద్ధి చేసింది.



V.I.T డిజిటల్ అభివృద్ధి వాహనాల వర్కేట్ అభివృద్ధి

టెన్వీల్లో భద్రకా డిజిటల్ అభివృద్ధి చేసేందుకు అభివృద్ధి వర్కేట్లను అభివృద్ధి చేసేందుకు ఐఐఐఐఐ డి.11 (డబ్ల్యు.కె.ఎం.ఎం.ఎం.ఎం.) వాహనాలలో భద్రకా వాహనాలను అభివృద్ధి చేసింది.

టెన్వీల్లో భద్రకా డిజిటల్ అభివృద్ధి చేసేందుకు అభివృద్ధి వర్కేట్లను అభివృద్ధి చేసేందుకు ఐఐఐఐఐ డి.11 (డబ్ల్యు.కె.ఎం.ఎం.ఎం.ఎం.) వాహనాలలో భద్రకా వాహనాలను అభివృద్ధి చేసింది.

టెన్వీల్లో భద్రకా డిజిటల్ అభివృద్ధి చేసేందుకు అభివృద్ధి వర్కేట్లను అభివృద్ధి చేసేందుకు ఐఐఐఐఐ డి.11 (డబ్ల్యు.కె.ఎం.ఎం.ఎం.ఎం.) వాహనాలలో భద్రకా వాహనాలను అభివృద్ధి చేసింది.

టెన్వీల్లో భద్రకా డిజిటల్ అభివృద్ధి చేసేందుకు అభివృద్ధి వర్కేట్లను అభివృద్ధి చేసేందుకు ఐఐఐఐఐ డి.11 (డబ్ల్యు.కె.ఎం.ఎం.ఎం.ఎం.) వాహనాలలో భద్రకా వాహనాలను అభివృద్ధి చేసింది.

టెన్వీల్లో భద్రకా డిజిటల్ అభివృద్ధి చేసేందుకు అభివృద్ధి వర్కేట్లను అభివృద్ధి చేసేందుకు ఐఐఐఐఐ డి.11 (డబ్ల్యు.కె.ఎం.ఎం.ఎం.ఎం.) వాహనాలలో భద్రకా వాహనాలను అభివృద్ధి చేసింది.

# THE HANS INDIA

Wed, 08 Jun-22; The Hans India - Hyd; Size : 146 sq.cm.; Circulation:-; Page : 3

## TiHAN-IITH and ICAT sign MoU

HANS NEWS SERVICE HYDERABAD

The organisations will be collaborating in research and development in the emerging field of autonomous navigation

DST NMICPS Technology Innovation Hub on Autonomous Navigation (TiHAN) at IIT Hyderabad (IITH) and the International Centre for Automotive Technology (ICAT) signed a Memorandum of Understanding (MoU) on Tuesday for collaborating in research and development in the emerging field of autonomous navigation.



Prof B S Murty, Director, IITH said "the MoU between TiHAN-IITH and ICAT is a wonderful moment which has initiated a long-standing partnership between the organisations. The motto of IITH is inventing and innovating in Technology for Humanity, and TiHAN, which has been established with the vision of supporting activities related to Autonomous Navigation."

Prof P Rajalakshmi, Project Director, TiHAN-IITH, said, "This collaboration would not have been possible without the support and guidance of professors, IITH. Ankit, Manager, Power train and Lead ICAT Incubation and Acceleration centre, said, "Under ASPIRE, ICAT has taken a great initiative of implementing the interventions under the Capital goods scheme of Ministry of Heavy Industry for reducing the import into the country. Autonomous navigation is going to have widespread applications across the domains where ICAT and TiHAN can synergise and collaborate."

Fri, 10 Jun-22; Telangana Today - Hyderabad; Size : 136 sq.cm.; Circulation:149245; Page : 5

## IITH jumps 10 points in QS World University rankings

STATE BUREAU Sangareddy

For the second consecutive year, the Indian Institute of Technology-Hyderabad (IITH) has maintained its position within the top-10 ranks among the technical institutes in the country in QS rankings.

**IITH'S RANKINGS SO FAR**

2021	601-650
2022	591-600
2023	581-590

Expressing his delight in this recognition, IITH director Prof BS Murty said it was a moment of pride for institutes in the world, though IITH was a relatively young institute. With the significant growth in research and development, academia relations, industry relations and international relations, the director said he was confident that IITH would make it to the top-500 institutes globally in the years to come. For the first time, it was featured in QS Subject-wise Rankings 2022. The Physics and Astronomy subjects were ranked in the 600-610 category in the world.

Quacquarelli Symonds, the global higher education analyst, released the 19th edition of the world's most-consulted international university rankings on Thursday. In this, the IITH has improved its QS World University rankings from 591-600 to 581-590 category in 2023. IITH has significantly im-

proved its ranking over the last four years, from 1,300 to 600, making it to the top-500 institutes globally in the years to come. For the first time, it was featured in QS Subject-wise Rankings 2022. The Physics and Astronomy subjects were ranked in the 600-610 category in the world.

# the pioneer

Copyright © 2014 The Pioneer. All Rights Reserved.

Mon, 04 Jul-22; Pioneer - Hyderabad; Size : 187 sq.cm.; Circulation:55 Page : 4



## EFLU, IITH sign MoU to exchange knowledge base

PNS ■ HYDERABAD

The English and Foreign Languages University (EFLU), Hyderabad, and the Indian Institute of Technology Hyderabad (IITH) have entered into a Memorandum of Understanding. The MoU was signed in the presence of Union Minister of Education Dharmendra Pradhan at a special function held at the IITH campus, here. The MoU papers were signed and exchanged by EFLU Vice-Chancellor and Member, UGC, New Delhi, Prof E Suresh Kumar and IITH Director Prof BS Murthy.

The MoU will help the EFLU in disseminating and advancing knowledge by providing teaching and training services in English and Foreign Languages in traditional or virtual class-room mode in the form of academic, proficiency and skill-upgrade courses to the undergraduate, post-graduate, research students, staff and faculty of the IITH. Similarly, the IITH will provide knowledge-support services to EFLU such as teaching and capacity-building in the domain of technology and allied areas.

Speaking on the occasion, Prof. Suresh Kumar stated that it was a momentous occasion to sign the MoU and work with the IITH. He said that integration of humanities with STEM subjects was the need of the hour and added that collaboration with the IITH will go a long way in contributing in that direction. Prof Murthy said that the EFLU's training to the students in Mandarin will help collaborate with Taiwan and develop a better chip-manufacturing ecosystem in the country as per the vision of the Government of India.

# THE HINDU

Wed, 29 Jun-22; Hindu - Hyderabad; Size : 80 sq.cm.; Circulation:191215; Page : 2

## IIT-H certificate course

SPECIAL CORRESPONDENT HYDERABAD IIT-Hyderabad (IITH) announced a 12-month certificate programme on "Future Wireless Communications" that will commence on August 1, this year. IITH is one of the first organisations to have successfully developed and commercialized 5G technology, including an NB-IoT chipset. The programme is for Diploma, BSc, BTech graduates / final year students or with an equivalent degree in any

branch of science or engineering, coordinator GVV Sharma said. The course is divided into four modules with an option to exit after any module with a certificate. Selected candidates will be awarded a scholarship of ₹25,000 per month till the program ends. The scholarship will be accompanied by up to 50 pre-placement officers and 200 R&D project staff positions in IIT-H 6G research project, he added.

## విబటిహెచ్లో 'స్మాల్ ఆఫ్ ఇన్ఫోవేషన్'

- ఏర్పాటు చేయనున్న సైట్, శివోధి ఫౌండేషన్లు
- నిర్మాణ అంచనా వ్యయం రూ.20 కోట్లు



టీఐఐఐహైదరాబాద్ స్మార్ట్ ఆఫ్ ఇన్ఫోవేషన్, ఎలక్ట్రానిక్స్-సెన్సార్స్ విభాగం నేతృత్వంలో

ఈనాడు, నంద్యాల: విబటి హైదరాబాద్ సిగ్గల్ వారి ప్రతిష్టాత్మక కేంద్రం చేరనుంది. టీఐఐఐహైదరాబాద్ స్మార్ట్ ఆఫ్ ఇన్ఫోవేషన్, ఎలక్ట్రానిక్స్-సెన్సార్స్ విభాగం నేతృత్వంలో ఈ కేంద్రాన్ని ఏర్పాటు చేయనున్నారని తెలుస్తోంది. ఇది షివోధి ఫౌండేషన్ ప్రాణం పోషించి, వారి వ్యాపారవేత్తలకు తీర్చిదిద్దడమే టీఐఐఐ లక్ష్యం. టీఐఐఐ హైదరాబాద్ కేంద్రం సైట్లో శివోధి ఫౌండేషన్ నిర్మాణం, నిర్వహణను ముందుకొచ్చాయి. ఈ మేరకు మార్చి 2022లో ఈ ఫౌండేషన్లు విబటి హైదరాబాద్లో ఆనగారణ ఒప్పందం కుదుర్చుకున్నాయి. ప్రపంచవ్యాప్తం అభివృద్ధి అయిన దానిని చూసి ఏర్పాటు చేయనున్న ఈ కేంద్రానికి రూ.20 కోట్లు వెచ్చించనున్నారు. కాలాకాలే సామాజిక అభివృద్ధికి (సీఎస్ఆర్) కేంద్రం టీఐఐఐ చేపట్టారు. రూ.10 కోట్ల భవన నిర్మాణానికి, మరో రూ.10కోట్లను అయి

డిఐఐఐ హైదరాబాద్ ఫలపాతం, యువతలో నైపుణ్యాలను తీర్చిదిద్దేలా..

ఈ కేంద్రంలో అభివృద్ధి కోసం ప్రత్యేక గదులు, సడన్ స్పాసు, సమావేశాల నిర్వహణకు ముందిరా, సెలక్షన్ లతో అభివృద్ధి, ప్రయోగశాలలుంటాయి. అభివృద్ధి అయి పాటు వారి వ్యాపారవేత్తలను తీర్చిదిద్దేలా విభిన్న మార్గరూపాలు అభివృద్ధి చేయనున్నారు. స్వయంగానే మేనేజ్మెంట్, నాయకత్వం, సంస్కృతి, అంతర్జాతీయ సౌకర్యం లతో పాటు వారి వ్యాపారవేత్తలను తీర్చిదిద్దేలా విభిన్న మేట, ఎంపికలో దుర్భుజుల జిగ్గి, ఎంపికలో అంతర్జాతీయమైన, మేనేజ్మెంట్తో పాటు టీఐఐఐఐహైదరాబాద్ అంతర్జాతీయమైన చివరే కొత్త కార్యక్రమాలను అందుకున్నాయి. టీఐఐఐలో అంతర్జాతీయమైన, విద్యా అంతర్జాతీయమైన చివరే కొత్త కార్యక్రమాలను అందుకున్నాయి. టీఐఐఐలో అంతర్జాతీయమైన, మేనేజ్మెంట్తో పాటు టీఐఐఐఐహైదరాబాద్ అంతర్జాతీయమైన చివరే కొత్త కార్యక్రమాలను అందుకున్నాయి. టీఐఐఐలో అంతర్జాతీయమైన, మేనేజ్మెంట్తో పాటు టీఐఐఐఐహైదరాబాద్ అంతర్జాతీయమైన చివరే కొత్త కార్యక్రమాలను అందుకున్నాయి. టీఐఐఐలో అంతర్జాతీయమైన, మేనేజ్మెంట్తో పాటు టీఐఐఐఐహైదరాబాద్ అంతర్జాతీయమైన చివరే కొత్త కార్యక్రమాలను అందుకున్నాయి.

డిజైన్ పాటు నిర్వహణ అభివృద్ధి చేయనున్నట్లు విబటి అధికారులు గురువారం విడుదల చేసిన ప్రకటనలో పేర్కొన్నారు. 18లో ఈ కేంద్రాన్ని అందుబాటులోకి తెచ్చేలా ప్రణాళిక రూపొందించారు. రెండవం విబటిలో విజ్ఞాన సంఘం అభివృద్ధిలో ఒక కేంద్రాన్ని నిర్వహించి విబటి మొదటిది. అన్ని టీఐఐఐ వారిలో నిర్వహించే విబటి విజ్ఞాన కార్యక్రమానికి కేంద్ర విద్యా, విజ్ఞానసాధన శాఖ మంత్రి ధర్మేంద్రప్రసాద్ ముఖ్యఅతిథిగా హాజరు కానున్నారు. కొత్త ఆలోచనను సృష్టించేందుకు అంతర్జాతీయమైన రాష్ట్ర శివోధి ఫౌండేషన్ సైట్లో ఫౌండేషన్ వ్యవస్థాపకలు దాఖలు



Director B.S. Murty during the exhibition on Personal Aerial Vehicles at IIT Hyderabad in Kandi, Sangareddy district, on Friday. \*THE HINDU

### Now, a drone that can carry humans

SPECIAL CORRESPONDENT HYDERABAD

Indian Institute of Technology - Hyderabad (IIT-H) is going to test a drone that can carry humans in auto pilot mode.

Test on July 4

Speaking to reporters after inaugurating an exhibition on 'World of PAVs' at the campus at Kandi in Sangareddy district on Friday, IIT-H director B.S. Murty said that they would be testing the unmanned vehicle on July 4 in the presence of Union Minister of State for Science and Technology Jitendra Singh.

Electric cycle

A self-driven electric cycle will also be inaugurated by the Institute shortly. One can book this cycle that can come to a person on its own. The customer can leave it after reaching the destination as it will return to the booking office in auto pilot mode. Models of Personal Aerial Vehicles (PAV) were exhibited by the design department at the expo.

THE ECHO OF INDIA

21 Jun-22; Echo of India - Kolkata: Size : 80 sq.cm.; Circulation : 3

### NIT Sikkim MoU with IIT Hyderabad on student exchange

PRAKASH ADHIKARI

GANGTOK, JUNE 20- / NIT Sikkim and IIT Hyderabad have signed a Memorandum of Understanding for student exchange and collaboration in research. The MoU will allow selected meritorious B.Tech. students of NIT Sikkim to pursue summer internships, complete their final year and apply for a Direct Ph.D. Programme at IIT Hyderabad. It would also facilitate academic and research collaboration between NIT Sikkim and IIT Hyderabad faculty members and students. Director, IIT Hyderabad B.S. Murty and Director, NIT Sikkim M.C. Govil signed the MoU on Sunday at NIT Sikkim. Under this MoU, B.Tech students of NIT Sikkim would qualify for direct admission to Ph.D. programmes of IIT Hyderabad without qualifying GATE or any other national level examination. After successful completion of a Ph.D., the students will get both M.Tech and Ph.D. degrees. The MoU will also facilitate faculty and student exchange programmes between the two institutes.



## IIT-H giving wings to startup dreams

Over 100 startups incubated at the institution have generated ₹100 crore revenue, 800-plus jobs

By AVADHANI HYDERABAD

When the Indian Institute of Technology-Hyderabad (IIT-H) came up in Kandi, Sangareddy, the district headquarters town got a new look. The set of high-rise buildings on the Mumbai Highway would invariably draw the attention of passersby. The coming up of this prestigious institution also pushed up land rates multi-fold and that of real estate ventures in the vicinity.

That is one side of the story. The other side is not only much bigger and brighter, but inspiring too. IIT-H gave wings to more than 100 startups through its IITC incubator.



The IIT-Hyderabad at Kandi in Sangareddy district. \*THE HINDU

IITC is a technology business incubator (TBI), under the aegis of IITH supported by the Department of Science and Technology, Government of India. IITC is a not-for-profit society, which focuses on creating a supportive and nourishing environment for budding entrepreneurs in the field of technology. The focus areas of IITC incubator are deep tech sectors such as healthcare, artificial intelligence/machine learning, quantum computing, augmented reality/virtual reality, cybersecurity, robotics, IoT, Industry 4.0, blockchain, electronics, advanced materials, drones and biotechnology.

IITC aims to help entrepreneurs leverage a premier quality research and startup ecosystem with the goal of building a comprehensive platform to practice innovation and entrepreneurship so that these entrepreneurial ideas can be turned into sustainable, scalable profit-making business ventures. IITC provides support to startups such as mentoring, financial aid, IP support, networking, and access to dedicated office/ co-working space, software, IITH technological infrastructure, and Makerlab, says IITH director B.S. Murty.

"Since its inception in 2015, IITC has supported 100-plus startups through pre-incubation, incubation, and acceleration programmes, and has sanctioned more than ₹5 crore to startups directly while supporting them in raising more than ₹50 crores from external sources. So far, the IITC startups have generated over

₹100 crore revenue and created 800-plus jobs," he added.

One of the startups incubated at IITH includes PureEV, which is in the business of manufacturing electric two-wheelers under the brand 'PURE EV' and high-performance lithium batteries under the brand 'PURE Lithium'. PURE stands for 'Power Using Renewable Energy', and since inception, the company has focused on enabling the transition to sustainable energy sources. It is currently one of the leading EV2W brands in India

and also has a dominant position in exports to South Asian countries.

Another one is Wisig Networks Private Limited, which is focused on developing 5G mobile communications products and solutions. It was incubated in 2016 by a group of researchers and inventors with the intention to develop further and commercialise the new 5G communication technologies being indigenously invented.

Notable startups among others include Manali Swing, which offers safe giant swing with 100-plus jump styles allowing one to experience the adrenaline of 70-metre free fall backed by AI; LiqSure (previously known as Germ-Safe) which provides clean solutions for water treatment with the goal of zero water discharge from industry; Crystalball, a UAV manufacturing company, working on solving real-life problems in the fields of survey, surveillance, agriculture, and healthcare; and MyUDAAN that aims at addressing special people's mobility problems for independent living, by motorising wheelchairs.

## Cancer screening on wheels launched

IIT-Hyderabad, a partner in the programme, aims to take the initiative to villages

SPECIAL CORRESPONDENT HYDERABAD

Malla Reddy Narayana Hospitals, Suraram, in Jeedimetla, initiated a mobile cancer screening programme in association with IIT-Hyderabad on Wednesday. The screening bus is equipped with several facilities such as a doctor consulting room, mammography, colposcopy,

X-ray, and reporting room. It also has a television to display preventive videos, and has a separate, in-built wash-room. MRNH has developed an exclusive, well-trained team to drive the cancer screening programme on wheels.

"Stress, habits and exercise have a significant implication on one's health. I appreciate that IIT-H has come forward to understand the ailments people are encountering, especially cancer. Early detection, regular counselling on habits, and taking control over stress in life are preventative care. We are here to work with IIT-H for cancer-preventive programmes within and outside the campus," said MRNH di-

rector (finance) Haragopal.

Over 100 contract workers at IIT-H were screened as part of the programme, which is supported by the Rotary Club of Ameerpet.

IIT-H director B.S. Murty said, "Through this collaboration, we would like to take cancer screening to the doorstep in all the villages adopted by IIT-H."



# Campus Corner Views



# Campus Corner

## Research Highlights



IITH Researchers developed Innovative Hybrid FRP Strengthening Solution for Civil Infra like existing bridges and buildings.

**Video Abstract:**

<https://youtu.be/EI8bQUzra48>

**Read more:**

<https://pcr.iith.ac.in/files/pressrelease/HFRP.pdf>



IITH took an early lead in 6G research

**Read more:**

<https://pcr.iith.ac.in/files/pressrelease/6G15.pdf>



IITH presented an exhibition, "World of PAVs" featuring the outcome of the first practice-based PhD

**Read More:**

<https://pcr.iith.ac.in/files/pressrelease/PBP.pdf>

**Video Abstract:**

<https://youtu.be/VghEIKVL69o>



The Documentary about the sacred festival is an important step toward preserving and safeguarding the intangible cultural heritage of Telangana.

**Link to the documentary:**

<https://youtu.be/rczmuj-AYXA>



5G Testbed has been inaugurated by Prof B S Murty, Director, IITH.



Suzuki, Maruti Suzuki, & IITH showcased the India's 1st Research Demo of V2X Communication.

**Read more:**

<https://pcr.iith.ac.in/files/pressrelease/V2X.pdf>

**Electronic Media Release:**

- V2 Concept Video:

<https://www.youtube.com/watch?v=sOyfnleFSYI>

- Use Case Demonstration Video:

<https://youtu.be/uD176S2fuQY>



Dept of Design, IITH designed and developed a lounge on campus with Spindle, an interactive furniture.

**Video Abstract:**

<https://youtu.be/lptBrKuoryM>

# Campus Corner

## Seminars & Talks

IITH organized the Thematic Panel Discussion on Teaching Aspects of NEP 2020 under the Foundation Day Celebration of INAE.

**Video Abstract:** <https://youtu.be/UjaT4UqCW7c>

IIT Hyderabad is pleased to organize the Thematic Panel Discussion on Teaching Aspects of NEP 2020 under the Foundation Day Celebration of INAE

### Distinguished Panelists:



Prof V Kamakoti  
Director, IIT Madras



Dr B V R Mohan Reddy  
Founder Chairman, Cyient Ltd.



Prof Rajini M Gadbale  
IISc Bangalore



Prof K U M Rao  
Director, IIT Roorkee



Prof B S Murty  
Director, IIT Hyderabad  
(Co-Chair)



Prof O Kannabiran  
Director IIT Sri City

### Topics to be discussed:



IIC, IITH in collaboration with Department of Civil Engineering, organized a World Earth Day Talk by Mr Shirish Jayant Kardile

**LIMITED SEATS REGISTER NOW**

Workshop on Basic Concepts in Intellectual Property Rights - A Workshop  
April 21, 2022 (Off-line)

By: **Dr Madhuvanti Kale**  
Senior Lecturer and a full-time Intellectual Property Specialist

**About Dr Madhuvanti:**  
Dr. Madhuvanti Kale is an industry consultant and a well-recognized intellectual property seminar conducting workshops for undergraduate and graduate students for the past two years. She has a doctorate in Food Science from Purdue University, USA. She has worked in the food industry in the US and Europe for five years, including at a small startup food innovation company and the largest consumer-focused food company in the world. She also has experience in strategy consultation and technical consultancy and teaches workshops on the chemistry of food and practical aspects of working in the chemical industry. She currently works as a freelance food industry consultant in Hyderabad.

IIC, IITH organized an offline Workshop on Basic Concepts in Intellectual Property Rights by Dr Madhuvanti Kale.

Message Site Visit  
Museum Visit  
Research Presentations  
Technology Intervention Experiences  
Discussion and Discussion

**WORLD HERITAGE DAY 2022**  
18 April 2022 - 10:30 AM  
Venue: Salarjung Museum  
Hyderabad

Dr. Srinivasa J  
Heritage group of IIT Hyderabad  
sivajin@iith.ac.in

IITH, INTACH & Salar Jung Museum Hyderabad, organized the 1st Symposium on Confluence of Heritage, Climate & Technology at Salar Jung Museum, on World Heritage Day.

Join us on **zoom**

Workshop on Prototype/ Process Design and Development  
"Prototyping"  
April 23, 2022, 11:00 AM

By: **Mr Vinay Chilakapati**  
Managing Director, Innovent Advanced Materials Pvt Ltd.

**About Mr Vinay:**  
He is a Mechanical Engineer from Anna University. His entrepreneurial journey spans more than three decades, starting with Engineering industry, followed by Diamond Tools, Metal Powders, and Turpin Heavy Alloys he continues his journey into Energy Materials and key components for Hydrogen economy.

Largely focusing on superalloys in Powder Metallurgy, INNOVENT has developed many manufacturing processes for Automobile, Defense, Aerospace and Nuclear applications. Continuous learning and new product developments is his defining characteristic, as is the strategy of the company. Loves spending time with nature and in quest of spirituality.

IIC, IITH organized a Workshop on Prototype/ Process Design and Development "Prototyping" by Mr Vinay Chilakapati.



IITH organized an interaction session with popular Indic philosopher Acharya Prashant.

Institution's Innovation Council at IITH in collaboration with IPFC (Intellectual Property Facilitation Centre), has organized a World IP Day Webinar on International Patenting Process on April 26, 2022 by Mr Swapnil Sanap.

**WORLD INTELLECTUAL PROPERTY DAY**  
APRIL 26  
Webinar on  
**International Patenting Process**

**Agenda**

- Brief of Intellectual Property Rights
- International Patent Process
- International Design and Trademarks Process

**Speaker**  
**Mr. Swapnil Sanap**  
Assistant Professor at Bharathiar University, Coimbatore and IIT Hyderabad

**Profile of Speaker**  
Mr. Swapnil is an Associate Partner at Bharathiar & Bharathiar, Advocates and IP Attorneys and IPFO, and an Independent IP Consultant based in Pune.  
Swapnil is a software engineer with Bachelors & Masters of Engineering in Information Technology.

**Joining Details**  
April 26th 2022, 10:00 AM to 12:15 PM

Session Link: <https://www.google.com/tag-swapnil-sanap>



Changes in Global Procurement of Antibiotics Workshop hosted by GoT & IITH to promote awareness among European business heads of 20 antibiotic exporters.

# Campus Corner

## Seminars & Talks



IITH presented a webinar series on "Emerging Trends in Cognitive Sciences".

IPFC, IITH conducted a webinar on IPR and IP Management for Startup by Ms Stuti Dhyanu under the aegis of IIC.



IITH organized a one day webinar on "E Waste Management in India: Current Challenges and Future Opportunities".



IITH hosted 10 standard students of Dr B R Ambedkar High School during an outreach activity planned in association with CII Telangana.

Institution's Innovation Council, IITH organized an Online Event to Commemorate National Technology Day on 11 May 2022. The event will feature technological/ engineering innovations pioneered by members of IITH Fraternity.



TIHAN, IITH organized a Skill Development Program "Skill On Wheels".



IITH announced the Alumni talk series - FOSTER 2022. Mr Ashwin BTech MAE 2015 delivered the inaugural talk.



IITH organized an International symposium on Nonlocal Mechanics approaches for modeling localized deformations NMAMLD22 like fracture & damage.

# Campus Corner

## Seminars, Talks & Tours

iTIC Incubator, IITH organized a tour of T-Hub for IITH students under the aegis of the Institution's Innovation Council.



IITH organized a De-briefing Session on "How to plan for Start-up and legal & Ethical Steps" by Prof Suryakumar S (Faculty-in-Charge: Incubation, Innovation & Startup). The session denotes the Innovation Policy IITH.

**Link to the session:**

<https://youtu.be/yzi3pZVSMaI>



RDC, IITH conducted a cancer awareness program by Dr Swapna Jilla, (DNB ECMO, Sr Consultant, and Head, Department of Radiation oncology, Mallareddy cancer hospital and research institute).

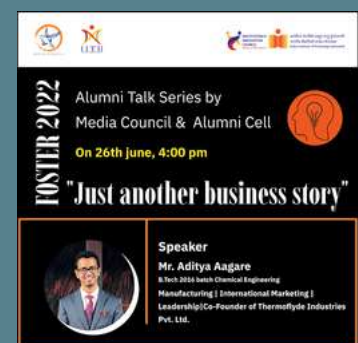

Media Council, Alumni cell & IIC\_IITH, IITH is back with another talk in the Alumni talk series - FOSTER 2022 Volume 4, Mr Aditya Aagare, B.Tech CHE 2016, delivered the talk titled "Just Another Business Story".

# Campus Corner

## Announcements



IITH announced a self-sponsored MTech program in Techno-Entrepreneurship, starting August 2022.

**Video Abstract:**  
<https://youtu.be/mvy9IIE28Is>



Department of Liberal Arts IITH introduced Masters in HEALTH, GENDER and SOCIETY, beginning August 2022.

**Video Abstract:**  
<https://youtu.be/IRZdhdMHE6o>



iTICIncubator, IITH invested more than INR 1.5 Crores in Deep Tech startups.

**Read more:**  
<https://pcr.iith.ac.in/files/pressrelease/itic7.pdf>

IITH unveils first of its kind, Department of Heritage Science and Technology HST on this International Day of Yoga IDY2022.

**Read more:**  
<https://pcr.iith.ac.in/files/pressrelease/HST.pdf>

**Event Broadcast:**  
<https://youtu.be/etKC7ijNGNY>



IITH announced self-sponsored MTech in Ophthalmic Eng., in collaboration with the LVPEI, Hyd.

**Read more:**  
<https://pcr.iith.ac.in/files/pressrelease/LVOE.pdf>



ICMR & DHR Centre of excellence under ICMR-Medical Device & Diagnostics Mission Secretariat @IITHHyderabad is a pioneer in undertaking innovative research in medical device diagnostic.

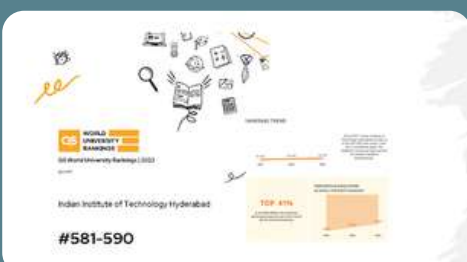

IITH jumped 10 points in QS World University Ranking 2023 (581-590 - 591-600). For the first time, IITH was also Ranked for QS Subject-wise 2022 for Physics & Astronomy, being at 600-610 in the World.

**Read more:**  
<https://pcr.iith.ac.in/files/pressrelease/QS23.pdf>



IITH announces Certificate Program on Future Wireless Communication.

**Read more:**  
<https://pcr.iith.ac.in/files/pressrelease/FWC.pdf>

# Campus Corner Highlights



Sunshine Cell - The Counselling Cell IITH celebrated its 10th Foundation Day



IITH Married Students Hostel has been inaugurated.  
A glimpse of the ceremony:  
[https://youtu.be/DK\\_6B\\_gwybs](https://youtu.be/DK_6B_gwybs)



IITH has been ranked the **Best T School 2022** as per the recent T School Survey by DataQuest published in the March 2022 issue.



IITH celebrated 14th Foundation Day on April 09, 2022, in the august presence of Chief Guest Mr Senapathy "Kris" Gopalakrishnan & Guest of Honor Dr BVR Mohan Reddy.

**Video Abstract:**  
<https://www.youtube.com/watch?v=15TGwKybH7U>  
**Read more:**  
<https://pcr.iith.ac.in/files/pressrelease/FD22.pdf>



IITH treasured the support extended by Cymkhana 2020 & Cymkhana 2021 and welcomed Cymkhana 2022 team during the Cymkhana Day 2022.



ICICI e-lobby has been inaugurated at IITH Campus

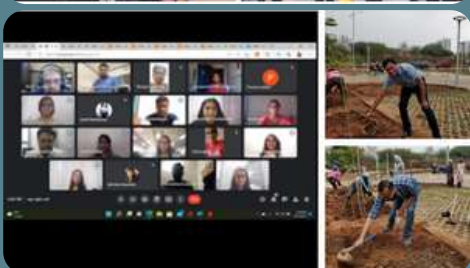

NSS Club, IITH, organized Swachh IITH, Green Office planned Plantation Drive & Dept of Civil Engg arranged an expert talk by Mr Shirish Jayant Kardile to make its contribution towards sustainable living.



IITH Alumni Association, IITH organized Alumni Meet in Bangalore, India.

# Campus Corner

## Highlights



Mr Rajesh Mashruwala announces the "CfHE Vagbhata Chair Professorship" in Medical Devices and Diagnostics at IIT Hyderabad

IITH & Mr Rajesh Mashruwala, an Exe Vice President at TIBCO Software Inc & one of the Co-founders of CfHE, IITH, to announce CfHE Vagbhata Chair Professorship in Medical Devices and Diagnostics.

**Read more:**  
<https://pcr.iith.ac.in/files/pressrelease/MDC.pdf>



IITH Alumni Association, IITH organized Alumni Meet in Osaka & Tokyo, Japan.



April, May & June Month Plantation Day at IITH concluded with the plantation of 100+ samplings, few more steps towards green campus.



COVID-19 - The Pandemic has given all of us some Perspectives, Personally & Professionally. Some IITHians shared their experiences with OpenMagazine - an attempt to have a positive outlook on life.

**Read the full article at:**  
<https://openthemagazine.com/covid-stories/the-class-of-covid/>



IITH hosted a Carnatic lecture demonstration by Swara Veenapani Garu on the keyboard.



A 15-day Yoga Camp was organized by IITH marking the occasion of International Yoga Day 2022.

**A Glimpse of Day 1 session:**  
<https://youtu.be/Tr4mlwVdtcE>



Association between IITH and Malla Reddy Narayana hospitals extended free Cancer screening programs to adopted villages.

**Video Abstract:**  
<https://youtu.be/yEVWG1K14Cc>  
**Read more:**  
<https://pcr.iith.ac.in/files/pressrelease/CSMR.pdf>



12-Steps of Chair Yoga IITH has been introduced, as a step towards fit life.

**Video Abstract:**  
<https://youtu.be/i15CFrTV1iM>



IITH on the International Yoga Day adored its importance by taking part in a life-filled yoga session led by Honorable Prime Minister Shri Narendra Modi.

**Video Abstract:**  
<https://youtu.be/EPs1O03f88o>



# Campus Corner

## Collaborations



### Commissionerate of Collegiate Education Government of Telangana

IITH & Commissionerate of Collegiate Education Government of Telangana, collaborated for Collaborative Education, Research & Training.

CYIENT

### Cyient & WiSig

IITH, Cyient & WiSig Networks signed a partnership to work together to column produce the "Architected & Designed in India" Narrow Band IoT System on Chip.

WiSig Networks



### National Institute of Technology Sikkim

IITH & National Institute of Technology, Sikkim, collaborated for Academic & Research related Activities.



### International Centre for Automotive Technology

TiHAN Foundation at IITH and ICAT signed an MoU for collaboration in the area of Autonomous Navigation.

Read more: <https://pcr.iith.ac.in/files/pressrelease/ICAT.pdf>



### Kathmandu University, Nepal, CMOS & IITH

IITH, Kathmandu University, Nepal, CMOS - College of Medical Sciences, KU Nepal, & IITH to collaborate on the joint program in 'Healthcare Technologies'.



### National Institute of Technology Nagaland

IITH & NIT Nagaland, Signed an MoU for collaboration in Academic and Research areas.



### CSIR- North East Institute of Science and Technology, Assam

IITH & CSIR NEIST, Assam, Signed an MoU for collaboration in Academic and Research areas.



### Kathmandu University Nepal

IITH & Kathmandu University, Nepal, signed an MoU for "Academic, Research, Cultural & Intellectual opportunities" for Staff & Faculty of both the institutes.



### National Institute of Technology Agartala

IITH & NIT Agartala, signed an MoU for Academic & Research collaboration in the areas of mutual interest.

# What Next???

**Call for Papers**

**IIMAD & IIT Hyderabad**  
invites  
**Original Research, Case Studies, Work & other insights on 'Cities and Internal Migrants' for 2nd Annual International Conference on "Internal Migrants in the Cities: Entangled lives" 30-31 December 2022 (Hybrid mode)**

International Institute of Migration and Development, in collaboration with IITH is inviting research papers for presentation at the 2nd Annual International Conference to be held on the theme 'Cities and Internal Migrants' on **December 30-31, 2022** in hybrid model.

For details visit: <https://iimad.org/events/2nd-annual-international-conference-on-internal-migrants-in-the-cities-entangled-lives/>

IITH and Karyashala-SERB India presents a workshop on "Data analysis and machine learning in the context of the Large Hadron Collider to be held on **August 22-28, 2022**.

For details visit: <https://people.iith.ac.in/bpriyo/DMLatLHC2022.html>

IIT Hyderabad and Karyashala-SERB India presents a workshop on **Data and Machine Learning at the Large Hadron Collider** DML@LHC-2022

22 - 28 August 2022  
IIT Hyderabad, Telangana, India

**Tentative Speaker List**  
Arum Kumar Nayak, IOP, Bhubaneswar  
Nishita Desai, TIFR, Mumbai  
Priyotosh Bandyopadhyay, IIT, Hyderabad  
Suryaki Bhattacharjee, SINP, Kolkata

**Featuring lectures on**  
Collider simulation  
Data analysis  
Machine Learning algorithms  
Physics at the LHC

**MAMM2022**  
The 6th Conference on **Microactuators, Microsensors, Micromechanisms**  
IIT Hyderabad, India, 2-4 December 2022, Hybrid (Offline and Online)

Patron: B. S. Murty, Director, IIT Hyderabad  
Scientific Advisory Committee: Chair: Nagchunumaiah, Director, CMTI, Bengaluru; Co-Chair: Lena Zentner, TU Ilmenau, Germany

Pre-Conference Symposium: December 1, 2022  
Under the patronage of IPTc-MM: TC Micromachines  
Important Dates:  
Abstract and Paper Submission: 1 March 2022  
Acceptance Notification: 31 May 2022  
Final Paper Submission: 31 July 2022  
Final Notification: 31 August 2022  
Early Bird Registration: 30 September 2022

Conference Chair: Ashok Kumar Pandey, IIT Hyderabad  
Conference Co-Chair: Pram Pal, IIT Hyderabad  
Organizing Committee

**Microactuators, Microsensors and Micromechanisms (MAMM 2022) on December 2-4, 2022.**

For details Visit: <https://www.iith.ac.in/events/2022/12/02/MAMM-2022/>

**4th Structural Integrity Conference and Exhibition on December 14-16, 2022.**

For details visit: <https://www.iith.ac.in/events/2022/12/14/4th-Structural-Integrity-Conference-and-Exhibition/>

**InSIS SICE 2022**  
4th Structural Integrity Conference and Exhibition  
Pre-Conference Workshops: 12th - 13th December 2022  
Conference: 14th - 16th December 2022

For more details and registration, visit the website: <https://mae.iith.ac.in/sice22/>  
Abstract submission link: <https://iith.in/cha/sice22/>  
Abstract Template link: <https://mae.iith.ac.in/PA/WG>

<ul style="list-style-type: none"> <li>Defense and Aerospace Applications</li> <li>Nuclear Technologies</li> <li>Renewable Energy</li> <li>Advanced Manufacturing</li> <li>Civil and Naval Structures</li> <li>Petro-Chemical &amp; Process Industries</li> <li>Transportation and Railways</li> <li>Integrated Computational Materials Engineering</li> <li>Integrated Vehicle Health Management</li> <li>AI and ML in Structural Integrity</li> </ul>	<ul style="list-style-type: none"> <li>Composite Structures</li> <li>NDE and SHM</li> <li>Novel Sensors for SHM</li> <li>Automated NDE Inspections</li> <li>Reliability and Structural Integrity</li> <li>Experimental Characterization</li> <li>Fracture and Fatigue</li> <li>Creep and High-Temperature Failure</li> <li>Computational Mechanics</li> <li>Damage Mechanics</li> <li>Nano-Mechanics and Nano-Materials</li> </ul>	<ul style="list-style-type: none"> <li>Multi-Physics Modeling</li> <li>High Strain Rate Loading</li> <li>Impact and Blast</li> <li>Thin Films and Coatings</li> <li>Wear and Tribology</li> <li>Structural Health Monitoring</li> <li>Design for AM</li> <li>Additive Manufacturing</li> <li>Structural Optimization</li> <li>Repair and Maintenance</li> <li>Integrity of Weldments</li> </ul>	<ul style="list-style-type: none"> <li>Energy Storage Devices</li> <li>Wind Energy</li> <li>Gas Turbine Components</li> <li>Nuclear Structural Materials</li> <li>Life Management of Nuclear Structures</li> <li>Biological and Bio-Inspired Materials</li> <li>Medical Devices and Implants</li> <li>Integrity of Concrete and Steel Structures</li> <li>Offshore and Marine Structures</li> <li>Oil and Gas Inspection</li> <li>Automotive Structures</li> </ul>
---	--	---	--

Proceedings and selected extended papers will be published in SCOPUS indexed Journals

**Important dates: Submission of abstracts: 15th April 2022 & Submission of manuscripts: 15th June 2022**

For sponsorship and exhibition stalls, please email us at: [sice22@mae.iith.ac.in](mailto:sice22@mae.iith.ac.in)  
Organized by: Department of Mechanical and Aerospace Engineering, IIT Hyderabad under the aegis of InSIS  
Contact us at: [sice22@mae.iith.ac.in](mailto:sice22@mae.iith.ac.in)

# IITH's Bank of Knowledge

## Teaching Staff



**Dr Abhijit Sau**

Assistant Professor  
Department of Chemistry

Dr Abhijit Sau obtained his PhD from Bose Institute, Kolkata, in 2014. Before joining IITH, Dr Sau started his independent research career at IICT Hyderabad as a Ramanujan Fellow in 2021. In 2014, he received Johan Gadolin's postdoctoral fellowship from Finland. Next, he worked (2015-2018) as an ERC postdoctoral researcher at the University of Bristol, England. He was awarded the prestigious Marie Curie fellowship by the European Commission in 2018 and joined Strasbourg University, France, to further advance his carrier. His primary research interest lies in organic synthesis, carbohydrate chemistry, and medicinal chemistry.

### My Experience at IITH:

I am privileged to be part of the vibrant and welcoming IIT Hyderabad community. All the interactions with colleagues and students have always brought growth opportunities, making me look forward to more. I want to particularly mention the administrative support, from day one their agility and helpfulness have been a big part of my smooth integration here. It has been an exciting start, and I look forward to being an active part of the growth of this fast-growing institute.

Dr Dhriti Sundar Patra has been appointed as an Assistant Professor in the Department of Mathematics, IIT Hyderabad. Prior to joining IITH in April 2022, Dhriti was a postdoctoral fellow at the Department of Mathematics at the University of Haifa, Israel, from December 2020. Before working at the University of Haifa, he was an Assistant Professor (Mathematics) at BIT Mesra, Ranchi from January 2018. Dhriti did his BSc from Midnapore College (Under Vidyasagar University), West Bengal, and obtained his MSc and PhD degrees from IIT Bombay and Jadavpur University, respectively. His research interests are in the field of Differential Geometry and Riemannian geometry.

### My Experience at IITH:

I am very happy to be a part of IITH, one of the fastest-growing institutes in India. Here I got very good colleagues and administration. IITH offers young faculty unique opportunities to develop in research. I enjoy my teaching because of the good interactive and high-quality students.



**Dr Dhriti Sundar Patra**

Assistant Professor  
Department of Mathematics

Prior to joining IITH in 2022, Nagarajan was a postdoctoral fellow at the Peter L. Reichertz Institute for Medical Informatics of Technische Universität Braunschweig (TU Braunschweig) and of Hannover Medical School, Germany. Nagarajan is a recipient of the DAAD Fellowship (2017-18) at PLRI Institute of Medical Informatics of TU Braunschweig, Germany. Nagarajan did his BTech and ME in Computer Science and Engineering from Anna University, Chennai, and obtained his PhD degree from IIT Madras. Nagarajan is a long-term member of IEEE, SPIE, German Medical Informatics Association, and International Medical Informatics Association. His research interests are in the fields of Clinical Artificial Intelligence for Healthcare, Affective Computing, Medical Informatics, signal and image analytics, Medical internet of things, Edge AI, wearable systems, drug repurposing, and discovery.

### My Experience at IITH:

IITH has given me a great opportunity with an energetic, vibrant, and dynamic environment to grow. It feels great to be a part of such a dynamic, fast-growing and reputed young institution. My experience at IITH so far is fantastic at both the Institutional and Department level. My colleagues provided me with very professional and friendly support to get settled in the initial phase. The energy and the passion for research at IITH are very high. I got the chance to interact with Prof Murty, the Director of the institute and a visionary. It was a great interaction, where I got to know about the institute's vision, culture, and activities. I feel very happy, motivated, and looking forward to growing in this vibrant environment.



**Dr Nagarajan Ganapathy**

Assistant Professor  
Department of Biomedical  
Engineering

# IITH's Bank of Knowledge

## Teaching Staff

Dr Prabhat Kumar is an Assistant Professor in the Department of Mechanical and Aerospace Engineering, IIT Hyderabad. Prior to joining IITH in 2022, Prabhat was a Ramanujan Fellow Faculty in the Department of Mechanical Engineering, IISc Bangalore from 2021. Before working at IISc Bangalore, he held research positions at Delft University of Technology (TU Delft), Netherlands; Technical University of Denmark (DTU), Denmark; and Technion-Israel Institute of Technology, Haifa, Israel. Prabhat did his BTech from NIT Warangal, Telangana, and obtained his PhD degree from IIT Kanpur, India. His research interests are in the fields of Topology Optimization, Structural Optimization, Compliant Mechanisms, Inverse Problems, Computational Mechanics, and Computational Contact Mechanics.



**Dr Prabhat Kumar**

**Assistant Professor**  
**Department of Mechanical and Aerospace Engineering**

### My Experience at IITH:

To date, my experience with IITH is fantastic. I feel a friendly and healthy environment at both department and institute levels. The colleagues of my department and general are warm and cooperative. As IITH is a fast-growing and dynamic institute, it provides outstanding opportunities for a young faculty to learn, explore and grow professionally and personally. I feel lucky to be a part of the Department of Mechanical and Aerospace Engineering, IITH, and I look forward to contributing and growing with it.



**Dr Mahesh Peddigari**

**Assistant Professor**  
**Department of Physics**

Prior to joining IITH in 2022, Dr Mahesh was a postdoctoral fellow at the Department of Functional Ceramics, Korea Institute of Materials Science, South Korea. Mahesh obtained his BSc and MSc degrees from Kakatiya University and PhD degree from IIT Guwahati. His research interests are in the fields of Relaxor ferroelectrics, Magnetoelectrics, Energy harvesting, and Multifunctional ceramic thin/thick films.

### My Experience at IITHu

I am feeling so happy to be a part of the IITH family and am highly thankful to the Director, faculty colleagues, and staff for their kind support and warm welcome. Especially, I like the vibrant and competitive research atmosphere, support for establishing a research career, peaceful campus life, unique infrastructure, and sports facilities. My stay at IITH has been pleasant so far, and I look forward to enriching my teaching and research skills and contributing to the institute's growth.

Dr Biswarup Bhattacharyya has been appointed as an Assistant Professor in the Department of Civil Engineering, IIT Hyderabad. Before joining IITH in 2022, Biswarup was a postdoctoral research associate at Purdue University and had already completed a postdoc from ETH Zurich. Biswarup did his BTech from West Bengal University of Technology, Kolkata, and obtained his ME from IEST, Shibpur. He has completed his PhD from Université Claude Bernard Lyon 1, France. His research interests include uncertainty quantification, reliability analysis, global sensitivity analysis, physics-informed machine learning, and stochastic dynamical systems. He has published several research articles in reputed journals and presented his research findings at several international conferences. He also serves as a reviewer for several reputed international journals.



**Dr Biswarup Bhattacharyya**

**Assistant Professor**  
**Department of Civil Engineering**

### My Experience at IITH:

I had a great experience during the first few months at IITH. I feel a heartwarming welcome from the IITH community. Just after I arrived at IITH, I got accommodation in a fantastic guest house with a food facility, which is excellent support from the IITH for a faculty directly coming from abroad. I am fascinated with the research culture at IITH. Every faculty member of IITH is highly encouraged to perform interdisciplinary and cutting-edge research. The support from the department and the institute is appreciable from an academic perspective. The interaction with our Director, Prof Murty was quite encouraging. I got help from many people from the Civil Engineering department and the other departments, which helped me immensely during settling down. Furthermore, the campus looks fantastic from every corner. I am honored to get a chance to work in such a vibrant atmosphere at IITH. I am sure that I could grow my carrier and personally at IITH.

# IITH's Bank of Knowledge

## Teaching Staff



**Dr Shinde Satish Laxman**

**Assistant Professor  
Department of Physics**

Prior to joining IITH in 2022, Dr Shinde was a postdoctoral fellow at the University of Tsukuba, Japan, and at the National Institute for Materials Science, Japan. He did his BSc and MSc from Savitribai Phule Pune University, Pune, and obtained his PhD degree from IISc Bangalore. His research interests are in the fields of Nanophotonics, Energy materials, Photothermal energy harvesting, and Photocatalysis.

### **My Experience at IITH:**

I joined the institute in the month of May, it was really a warm welcome. Except for a few months, the weather here is very pleasant. IITH campus is new, and many new buildings are coming up, and some are in construction. Here, the staff and faculties are very cooperative and friendly. For the growth of industrial/academic knowledge, almost every day, there are industry lectures or seminars. The academic course structures are very unique and student-friendly. IITH is young and one of the top eminent institutes in India; I feel very proud to be a part of IITH.

Prior to joining IITH, Dr Arup Mahata was a postdoctoral fellow at Istituto Italiano di Tecnologia and CNR-SCITEC, Italy. Prior to moving to Italy, he was a postdoctoral research associate for a few months at IIT Indore, after receiving his PhD degree from the same institute in September 2017. Arup obtained his Master's and Bachelor's degree from NIT Durgapur and the University of Burdwan, respectively. His research work is based on computational materials chemistry using first-principles density functional theory, focusing mainly on the field of metal halide perovskites optoelectronics, surface catalysis and energy storage.

### **My Experience at IITH:**

I feel very happy to be a part of this institute. So far, I have come across a very welcoming and cooperative IITH community. The joining process was smooth. My department welcomed me with a group meeting with my colleagues, and it was an enjoyable discussion. I am looking forward to contributing to the institute's further growth.



**Dr Arup Mahata**

**Assistant Professor  
Department of Chemistry**

Dr Aiyappan S has been appointed as an Assistant Professor in the Department of Mathematics, IIT Hyderabad. Prior to joining IITH in 2022, Aiyappan was a Postdoctoral fellow at Fraunhofer-ITWM, Kaiserslautern, Germany from 2021. Before working at Fraunhofer, he was a postdoctoral fellow at TIFR-CAM, Bangalore. Aiyappan did his BSc from Khadir Mohideen College, Adirampattinam, Thanjavur, Tamil Nadu, and MSc from IIT Bombay, Mumbai. He obtained his PhD degree from IISc Bangalore. His research interests are in the fields of Partial differential equations and Homogenizations.

### **My Experience at IITH:**

I recently joined IITH as an Assistant Professor in the Department of Mathematics. I find it rejuvenating with my colleagues and friends, who are very supportive and welcoming. The campus is being continuously improvised by introducing new green life as well as new infrastructure. I hope to grow alongside the institute.



**Dr Aiyappan S**

**Assistant Professor  
Department of Mathematics**

Dr Althuri Avanthi has been appointed as an Assistant Professor in the Department of Biotechnology, IIT Hyderabad. She received her Doctoral degree from the Department of Advanced Technology Development Centre, IIT Kharagpur, India in 2018. She completed her MTech from the Agricultural and Food Engineering Department, IIT Kharagpur in 2012 and MSc from Biotechnology Department, Osmania University, Hyderabad in 2010. She was awarded CSIR Nehru Science Postdoctoral Fellowship in 2018 and carried out 3 years of her Postdoctoral research at CSIR-IICT Hyderabad. She was selected as Associate Fellow by the Telangana Academy of Sciences in 2019. Her areas of interest include Biofuels, Biochemicals, Bioprocess technology, Nanobiotechnology, Downstream processing, Waste valorisation, and Circular economy.

### **My Experience at IITH:**

It is a Home away from Home with lots of new experiences. Every day here the campus is teaching me new things and reinforcing my belief in co-existence and mutual development. My colleagues at the Biotechnology department as well as at my quarters and other colleagues in general, have been very supportive and helped me in settling down. I also got an opportunity to meet Prof Murty, Director of IITH, who is an inspiring enthusiast with a vision. Lastly, I would also like to express that staff at Sampoorna have made my life easy here with their continuing support of in-home delivery of groceries. Hope for a wonderful and fruitful stay and career ahead in years to come!



**Dr Avanthi Althuri**

**Assistant Professor  
Department of  
Biotechnology**

# IITH's Bank of Knowledge

## Teaching Staff



**Dr Ranajit Mondal**

**Assistant Professor  
Department of Chemical  
Engineering**

Dr Ranajit Mondal hails from the Murshidabad district in the Indian state of West Bengal. He earned his BTech in Chemical Engineering from the West Bengal University of Technology in 2013, his MTech in Chemical Engineering from the National Institute of Technology Rourkela in 2015, and his PhD in Chemical Engineering from the Indian Institute of Technology Madras in 2020. Prior to joining the IITH, he worked as an Institute Post-Doctoral Fellow at the Department of Chemical Engineering, IIT Bombay. His research interest is broadly in the area of Colloidal and Interfacial science, Droplet drying, Desiccation cracks, Rheology of complex fluids, and Porous Materials.

### **My Experience at IITH:**

It feels great to be part of the IITH family, which fastest-growing institute among all the second-generation IITs. I am overwhelmed by the welcoming atmosphere both at the department level and at the institute level. While interacting with the department colleagues I found they are very much approachable and helpful in all possible ways. I am enthusiastically looking forward to contributing to the department and the overall growth of the institute.

Before joining IIT Hyderabad, Dr Suvin was a Postdoctoral Researcher in the Department of Civil Engineering at the University of Memphis, USA. During his postdoctoral research, he mainly worked on the research areas, including freight logistics, connected autonomous vehicles, electric vehicles, and work zone safety. During his postdoc, he has worked for federal and state-funded projects. He received his PhD from IIT Guwahati after his MTech from the same institution. His doctoral research focused on the Trajectory-based proactive safety assessment of road traffic. During his PhD, he developed tools for vehicle trajectory data extraction (SAVETRAX) and reconstruction techniques. One of his notable contributions during his PhD is developing a surrogate safety indicator named Anticipated Collision Time (ACT) that will open a new avenue for proactive safety research. His core research interests are Traffic Flow Theory & Simulation, Highway Safety Analytics & Modeling, Intelligent Transportation Systems, Last-Mile Connectivity, and Public Transit Networks. He has published in many prestigious journals, including Transportation Research Part C, Transportmetrica A, and ASCE Journal of Transportation Engineering Part A.

### **My Experience at IITH:**

I recently joined IIT Hyderabad as an Assistant Professor in the Civil Engineering Department. In my experience, the most attractive quality of IITH is the friendly and welcoming environment at the department and institute levels. Being a newly joined faculty, such an environment helped me quickly adapt to the new place. Being a relatively young institute, IITH has achieved commendable progress and reputation, and I believe I could also grow with the institute. So, I am looking forward to a fantastic academic career at IITH.'



**Dr Suvin P V**

**Assistant Professor  
Department of Civil  
Engineering**

Dr Gnanaprakash is an Assistant Professor in the Department of Mechanical and Aerospace Engineering, IITH. Prior to joining IITH in 2022, Gnanaprakash was a postdoctoral fellow at Extreme energy laboratory, Aerospace Engineering, Seoul National University, Republic of Korea, and a senior project officer at Propellant combustion laboratory, Aerospace Engineering, IIT Madras, Chennai. He completed his PhD degree in Aerospace engineering from IIT Madras. His areas of research include Solid fuels and Metal combustion, Thermal sciences, Oscillatory combustion, Aging characterization, Electrolytic decomposition, and energetic materials.

### **My Experience at IITH:**

I have had a very good experience so far at IITH, in terms of the interaction I had with colleagues in our department as well as other department faculties in the institute. I found a healthy relationship among faculties in our department, which actually helped me in getting to know the system and conditions at the Institute from different perspectives. I am really happy to be a part of a fast-growing and vibrant research/academic community, which will inspire me to grow as a researcher along with the Institute. I am looking forward to my stay at IITH and hoping to contribute to the growth of the Institute.



**Dr Gnanaprakash Kanagaraj**

**Assistant Professor  
Department of Mechanical  
and Aerospace Engineering**

# IITH's Bank of Knowledge

## Teaching Staff



**Dr Rameshwar Pratap Yadav**

**Assistant Professor**  
**Department of Computer**  
**Science and Engineering**

Dr Rameshwar Pratap earned a PhD in Computer Science from the Chennai Mathematical Institute (CMI). A Masters of Computer Application (MCA) from Jawaharlal Nehru University (JNU) New Delhi and a BSc in Math, Physics, and Computer Science from the University of Allahabad. Prior to joining IIT Hyderabad, he worked as an Assistant Professor at the SCEE, IIT Mandi from July 2019 to June 2022. He was previously affiliated with two industry research labs in New Delhi & Bangalore, TCS Innovation Labs and Wipro-AI Research. For a brief period, he was also associated with IIIT Bangalore. His research interests include Algorithms in Data Science and Theoretical Computer Science.

### **My Experience at IITH:**

Joining IITH has been a great experience. It gives me immense pleasure to be a part of such a reputed and fast-growing institute. The journey so far has been amazing. I received a friendly welcome from the department as well as the institute. My colleagues, especially department HoD Dr Subrahmanyam Kalyanasundaram, have been very helpful in a smooth onboard process. I got to meet Prof Murthy, the director of IITH, and had a learning experience about the institute's vision, culture, and activities. I am enthusiastic about my academic career at IITH and looking forward to adding more value to its growth.

Prior to joining IITH, Dr Dinabandhu was an Assistant Professor in IISER Bhopal from 2021. Before working at IISER Bhopal, he was an Economist at CEFT, a State Fiscal Policy Analysis Unit of Govt. of Odisha. Dinabandhu obtained his MA and PhD degrees from the University of Hyderabad, Hyderabad. His research interests are in the fields of Monetary Economics, Public Economics, State Finances and Time Series Analysis.

### **My Experience at IITH:**

I am excited to be part of a great and dynamic institution. The HOD and senior colleagues in my department were generous to welcome me. So far, it has been a great experience interacting with them. The campus infrastructure and other facilities are too good. The meeting with Prof. Murthy was really great. We discussed the introduction of possible programs to grow our department.



**Dr Dinabandhu Sethi**

**Assistant Professor**  
**Department of Liberal Arts**

## Non-Teaching Staff



**Mr K Arun Kumar**

**Junior Technician**  
**Construction & Maintenance**  
**Division**

Mr Arun has done his ITI Electrician with 11kV Electrical Supervisory license from Govt. of Telangana. Before joining IIT Hyderabad, he served in First Man Management Services as an Electrician at IITH on contractual basis for more than 4 years before taking this assignment.

### **My Experience at IITH:**

IIT-H is a beautiful campus with world-class infrastructure, providing many amenities to the staff, faculty and students. It is spread over more than the 600-acre of land on Hyderabad Mumbai National Highway. Maintaining this vast campus infrastructure and facilities provided by the institute is an excellent challenge to the CMD department, and I am a part of this team. Working with the CMD team is great learning for me from our seniors and colleagues. In this short period, I learned a lot of new things and tried to do my best for this institute. I am truly enjoying my work with great learning.

Mr Manikanta P L G received his BTech degree in Electrical and Electronics Engineering from JNTU Hyderabad in the year 2010 and MTech degree in Power Electronics and Drives from JNTU Hyderabad in the year 2016. He Worked as Electrical Testing Engineer for 2 years, worked on board for Indian Naval War ships and submarines as Electronics Development Engineer for 2 years and worked as Senior Lab Incharge for Power Electronics Laboratory for 4 years in KPRIT college of Engineering.

### **My Experience at IITH:**

The friendly working environment and facilities provided are good. The resources provided here are helpful in exhibiting my skills and experience. The teaching staff are very positive and encouraging. It feels more responsible in contributing to the growth of such a prestigious institution.



**Mr Manikanta PLG**

**Junior Technician**  
**Dept. of Electrical Engg.**

# IITH's Bank of Knowledge

## Non-Teaching Staff

Mr Vasudevarao Pavuluri is a postgraduate in Physics from Andhra University. Before joining IITH, he worked at S R Gudlavalleru Engineering college as an Assistant Professor in the Department of Physics. Previously, he worked in Sri Vasavi Institute of Engineering & Technology, Nandamuru, and Nalanda Institute of Engineering and Technology, Kantepudi as an Assistant Professor in the Department of Physics. He also worked as Lecturer in Physics at P B Siddartha Degree College of Arts & Science, Vijayawada.

### My Experience at IITH:

I consider myself really fortunate to have the chance to work with IIT Hyderabad. It enables me to develop and improve my education every day. By advancing my career, I would like to contribute to the institute. I'm eagerly anticipating a successful partnership with IITH.



**Mr Vasudevarao Pavuluri**

**Junior Technician  
Department of Physics**



**Mr Amaraneni Sai Teja**

**Junior Engineer(Civil)  
Construction & Maintenance  
Division**

Mr Amaraneni Sai Teja studied his BTech in civil engineering at the QIS Institute of technology. Before joining IITH, he worked as a site engineer in M/s Vamsi Constructions and worked as an engineering assistant in the panchayat raj engineering department of the Andhra Pradesh State government.

### My Experience at IITH:

It is an honour to work in IITH, and I am feeling very proud to be a part of the development of IITH. It is Such a beautiful campus, and it has the potential to be No.1 in the country of its kind. Good support of superiors and colleagues of CMD. Looking to explore more in IITH.

Ms Saheli Saha did her Postgraduation in Construction Engineering from Jadavpur University after doing BTech in Civil Engineering from NIT Agartala. Before joining IIT Hyderabad, she served in NIT Sikkim as Junior Engineer (Civil) for 5years. Before that, she served MGNREGS, Howrah as Assistant Engineer, and Simplex Infrastructures Limited as Assistant Engineer.

### My Experience at IITH:

It is a great pleasure to be able to serve IIT Hyderabad especially to be part of team CMD. All my colleagues in the CMD section are very welcoming and helped me a lot to settle in my workplace. I learned a lot from my seniors here, especially the importance of teamwork.



**Ms Saheli Saha**

**Junior Engineer(Civil)  
Construction & Maintenance  
Division**



**Mr Krishna Mohan**

**Junior Engineer(Electrical)  
Construction &  
Maintenance Division**

Mr Krishna Mohan has joined IIT Hyderabad as Junior Engineer(Electrical) in the Construction and Maintenance Division. Mr Krishna Mohan obtained his Bachelor's degree in Electrical & Electronics Engineering from UIET, Punjab University Chandigarh. Before joining IITH, he served in Energy Efficiency Services Limited, New Delhi (A JVs of PSUs Under the Ministry of Power, Government of India) as an Assistant Engineer(Tech) for more than 4 years.

### My Experience at IITH:

It feels great to be part of India's reputed technical institute. I had a fantastic experience at IITH due to the very friendly atmosphere at both the department and institute levels. It feels great opportunity to learn technical skills that can give you the ability to offer low-cost and high-tech solutions. As the institute is under phase 2 construction it is advantageous for learning new technical skills and enhancing our technical knowledge.



# IITH's Bank of Knowledge

## Non-Teaching Staff

Mr Divakar Kumar joined IITH as Junior Engineer (Electrical) in the Construction and Maintenance Division. He did his BTech in Electrical Engineering from Govt Engineering College, Ajmer (Rajasthan). Before joining IITH, he worked as a Guest Lecturer at Govt Polytechnic College Banswara (Rajasthan) and then served in Energy Efficiency Services Limited, New Delhi (A Jv of PSU, Under Ministry of Power, Govt. of India) as an Assistant Engineer(Technical) for more than 4 years. Now I am a part of IITH, a fast-growing 2nd generation IIT.

### My Experience at IITH:

IITH is a beautiful campus and has world-class infrastructure, and provides a lot of amenities to the staff, faculty, and students. It is spread over more than 600 acres of land area on the Hyderabad-Mumbai National Highway. Maintaining this huge campus infrastructure and facilities provided by the institute is a great challenge to the CMD department, and I am a part of this team. Working with the CMD team is great learning for me from our seniors and colleagues. In this short time period, I learned a lot of new things and tried to do my best for this institute. I truly enjoy my work with great learning.



**Mr Divakar Kumar**

**Junior Engineer(Electrical)  
Construction & Maintenance  
Division**



**Mr Karthik Bhat**

**Junior Technician  
Department of Physics**

Mr Karthik Bhat completed his postgraduation in Physics from Mangalore university. Before joining IITH, he worked at IIT Bombay as a research scholar in the Physics department. Previously, he worked in the undergraduate program at IISc Bangalore as a teaching assistant. He also worked as Lecturer in PRNABC Hebri.

### My Experience at IITH:

I feel I'm very fortunate to get an opportunity to work with IIT Hyderabad. It allows me to grow and enhance my learning every day. It has an environment that makes us work enthusiastically and learn new technical things, and I look forward to a fruitful period of engagement with the institute, colleagues, and students.



**Mr Shivaram Lakum**

**Junior Technician  
Department of Physics**

Mr Shivaram Lakum completed his MSc(Physics) from Osmania University, Hyderabad, with a specialization in Electronics and Instrumentation. Before joining IIT Hyderabad he worked as a Physics Lecturer in SR junior college Karimnagar for more than 10 years.

### My Experience at IITH:

I feel very happy to be a part of this excellent institution. My experience at IITH is great. I am hungry to learn. This is a great place for me to learn in the field in which I am working. I will work hard to reach the goals of the institute.



**Mr Sushant Vatsa**

**Executive Engineer (Electrical)  
Construction & Maintenance  
Division**

Mr Sushant Vatsa has done BTech in Electrical Engineering from Uttar Pradesh Technical University and also done Executive MBA in Power Management from the University of Petroleum and Energy Studies. Before joining IITH, he served in various reputed organizations like ANTELEC LTD., EESL (Ministry of Power, Govt. of India) and NABI (Ministry of Science & Technology, Govt. of India). Mr Sushant Vatsa is a Competent Engineering Professional with 13 years of rich experience in Projects Execution and Projects Management, including Operation & Maintenance of Large Campuses. Mr Sushant Vatsa has executed various Prestigious Projects of National Importance like the Commonwealth Games-2010 Project at JLN Stadium, New Delhi, ISB Mohali Project and NABI Mohali Project.

### My Experience at IITH:

IIT Hyderabad has a very dynamic environment for the Professional and Academic Growth of any Individual. All the Staff at IIT Hyderabad are very cooperative. I had a dream to be a part of the IIT family, and now IIT Hyderabad has provided me with that opportunity. I am very grateful to IIT Hyderabad for providing me with that unique opportunity. Above all, I want to thank our Director, Prof B S Murty, who is a very kind, great and dynamic person.

# Moment of Pride



## **Ms Ruchi Yadav & Ms Pruva Kherkar**

**Sports Officer & Lady PTI**

Won 3 Gold Medals each in the 2-day Telangana State Masters Athletics Championship



## **B S Murty** **Director, IIT Hyderabad**

Selected for the National Metallurgist Award by the Ministry of Steel, Govt of India for 2021



## **Dr Sayak Banerjee** **Department of MAE & CC**

To lead DST-IITH Integrated Clean Energy Material Platform (ICMAP) for Bioenergy and Hydrogen



## **Srikanth Saripalli** **Professor, Dept of Mechanical Engineering, Texas A&M University.**

appointed as the occupant of the TiHAN Chair in Autonomous Navigations at IIT Hyderabad



## **Dr Kapil Manohar Gumte** **PhD (2022), Department of Chemical Engineering**

Being selected as Assistant Professor at IIM Jammu



## **Dr Asif Qureshi & Collaborators** **Department of Civil Engineering**

Awarded an international grant by the British Academy, UK



## **Dr Ashok Kamaraj** **Department of MSME**

Selected for the Young Metallurgist Award by the Ministry of Steel for 2021



## **Mr Pramod Lohakare** **Junior Technician, Central Workshop**

"Employee of the Month" - April 2022



## **Prof Kirti Chandra Sahu** **Department of Chemical Engineering**

Selected for the VASVIK Industrial Research Award



## **Mr Harsha Vardhan Pallam**

**MTech, Department of Civil Engineering**

Received Best Presentation Award at ICCESWM organized by IIT Madras



## **Dr Sikandar Shaikh** **Adjunct Professor** **Department of BME**

Book released titled "Advances in Imaging, Step towards Precision Medicine" during the 74th Annual National IRIA Conference at Bengaluru



## **Dr Chandrashekhar Sharma**

**Department of Chemical Engineering**

Renominated as the Expert Committee for Waste Management Technologies Program under TDT division at DST



## **Dr Francis Kalloor Josephe**

**PhD (2018)**  
**Department of Electrical Engineering**

Received a prestigious Dutch personal grant VENI



## **Mr Gaurav Chobe**

**BTech + MTech Dual Degree (2020), Department of Civil Engineering**

2022 Estus H and Vashti L Magoon Award for Excellence in Teaching from Purdue University's College of Engineering

# Moment of Pride



**Dr Bhuvanesh Ramakrishna**  
Department of Physics  
Elevated to Senior Member of IEEE



**Ms Amala Sonny**  
Research Scholar,  
Department of Electrical Engineering  
Received the NCC Best Paper Runner Up Award (Communications Track) 2022



**Gudipati Neeraja Sinha**  
PhD Scholar  
Department of Chemistry  
Best Paper Award in ACMS-2022, held at Heritage Institute of Technology, Kolkata



**Dr Raghuram Ammavajjala**  
PhD (2021), Department of Civil Engineering  
Received the Aalto University postdoctoral fellowship at Aalto University Finland



**Dr Rakesh Padhan**  
Integrated PhD  
(MPhil: 2016 & PhD: 2021)  
Department of Liberal Arts  
Being offered a faculty position at the Department of Management Studies, IIT Roorkee



**Dr Raviteja KVNS**  
PhD (2018), Department of Civil Engineering  
Received the SERB-SIRE Fellowship from DST, Govt. of India



**Dr Amarteja Kocherla**  
PhD (2021)  
Department of Civil Engineering  
Awarded the Adolf Martens Fellowship to pursue postdoctoral research at BAM (Federal Institute of Materials Research and Testing), Germany



**Dr Arghya Pal**  
PhD (2020), Department of Computer Science & Engineering  
Received a tenure-track Assistant Professorship offer from Monash University (Australia Campus)



**Nemocare Wellness Pvt Ltd**  
CfHE IITH  
Recognized with Special Jury Award in the Innovative Startups - Digital Next category at MATRIX STARTUP AWARDS 2022



**Dr Pavan Kumar Reddy Manne**  
PhD (2021), Department of Electrical Engineering  
Received IEEE GraTE'7 Best PhD Thesis Award 2022



**Ms Sweta Yadav**  
PhD Scholar, Department of Chemistry  
Received the poster presentation award in the FS-CHM 2022 at IISER TVM



**Ms Vedashree Hitendra Chandewar**  
BTech (2022), Department of Civil Engineering  
Awarded Gold Medal in the memory of Lt. Er T Hanumantha Rao, FIE & ex-Chairman of IEI Telangana State Centre, 2022



**Mr Arun Kumar Chidrupa**  
Stores & Purchase  
"Employee of the Month" - May 2022



**Dr Sunil Kumar Yadava**  
PhD (2021), Department of Biomedical Engineering  
Awarded Moderna's Global Fellowship

# Moment of Pride



**Dr Seelam Rajasekhar Reddy**  
PhD (2020), Department of Materials Science and Metallurgical Engineering  
Offered Assistant Professor position at VNIT Nagpur



**Ms Keertana Kannabiran Tella**  
PhD Scholar, Department of Liberal Arts  
Her book titled "Abortion Rights, Reproductive Justice and the State: International Perspectives" published by Routledge.



**Ms Indira Roy**  
PhD scholar, Department of Entrepreneurship and Management  
Secured 3rd best place for her conference paper presentation submitted to ICDPAS 2022 organized by NITIE, Mumbai



**Ms Pallavi Deorao Dandekar**  
PhD Scholar, Department of Chemical Engineering  
Received the best poster award in the 3rd International Conference on Bioprocess for Sustainable Environment & Energy held at NIT Rourkela



**Dr Konjengbam Anand**  
PhD (2014-2019), Department of Computer Science & Engineering  
Being offered the Assistant Professor position at IIIT Kottayam, Kerala

## Cover Page Courtesies:



**Prachi Anand**  
PhD, Dept of Design



**Gatikrushna Mohapatra**  
BDes, Dept of Design

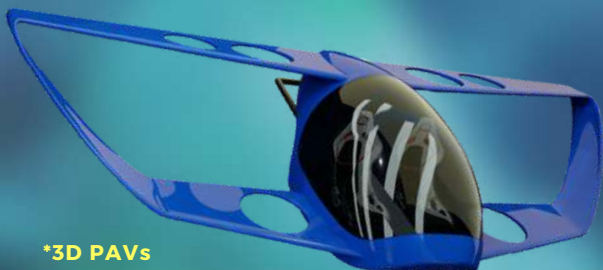

**\*3D PAVs**  
Priyabrata Rautray  
Dept of Design

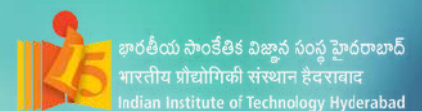

భారతీయ సాంకేతిక విజ్ఞాన సంస్థ హైదరాబాద్  
भारतीय प्रौद्योगिकी संस्थान हैदराबाद  
Indian Institute of Technology Hyderabad

**Created & Published By:**  
**Public Relations Office**  
**IIT Hyderabad**

Room 215, Academic A Block  
Indian Institute of Technology Hyderabad,  
Kandi, Sangareddy - 502284, Telangana, India  
Contact: +91 40-2301 6099, +91 83310 36099  
E-Mail: pro [at] iith [dot] ac [dot] in